

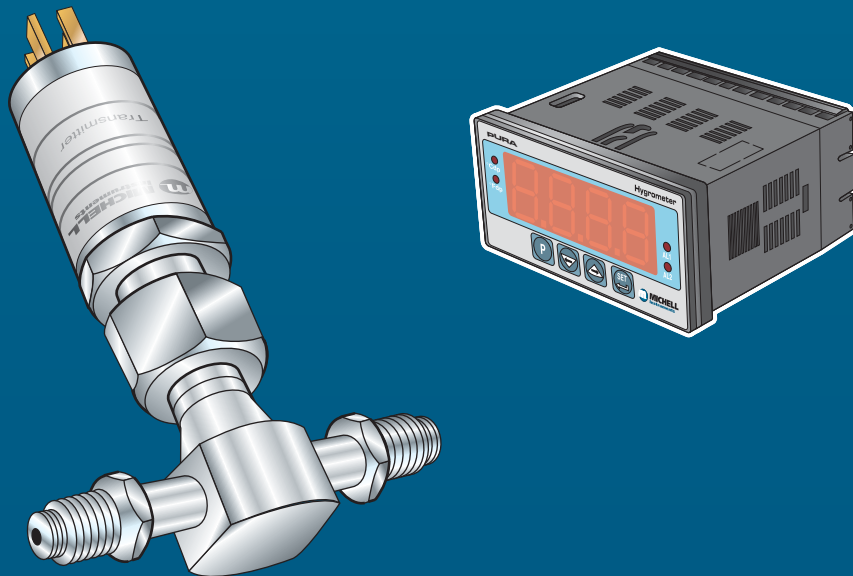

Pura Hazardous Area Online Hygrometer User's Manual



Inside front cover (blank)



Pura Hazardous Area Online Hygrometer

© 2016 Michell Instruments

This document is the property of Michell Instruments Ltd. and may not be copied or otherwise reproduced, communicated in any way to third parties, nor stored in any Data Processing System without the express written authorization of Michell Instruments Ltd.

Contents

Safety	vi
Electrical Safety.....	vi
Pressure Safety	vi
Toxic Materials	vi
Repair and Maintenance.....	vi
Calibration	vi
Safety Conformity.....	vi
EU Declaration of Conformity	vii
Abbreviations.....	viii
Warnings.....	viii
Recycling Policy.....	ix
WEEE And RoHS Compliance.....	ix
Calibration Facilities.....	ix
Manufacturing Quality.....	ix
Warranty	x
Return Policy.....	x
1 INTRODUCTION.....	1
2 DESCRIPTION	1
2.1 Display.....	2
2.2 Function Keys.....	4
2.3 Process Indicator Menu Structure.....	5
2.3.1 Flowchart Reading Method	6
2.3.2 Flowchart Example	7
3 OPERATION	8
3.1 Operational Requirements	8
3.1.1 Environmental Requirements – Process Indicator	8
3.1.2 Electrical Requirements	8
3.2 Mounting the Process Indicator.....	8
3.3 Electrical Connections	10
3.3.1 AC Power Supply Input.....	11
3.3.2 Preliminary System Test	12
3.3.3 DC Power Supply Input (Optional).....	13
3.4 Signal Output Connections	14
3.5 First Time Operation	16
3.6 System Alarms.....	17
3.6.1 Reversal of Default Alarm Switching Logic	18
3.6.2 Set-up Alarm Levels	20
3.6.3 Configure Analog Output Current Loop	21
3.7 Change Dew-Point Temperature Range.....	22
3.7.1 Span and Unit Settings	23
3.7.2 Configure Alarm Set-Point Limits	24
3.7.3 Change Scale Units (to ppm _v).....	25
3.7.4 Display Limits When Unit Scaled to ppmV	26
4 SENSOR INSTALLATION.....	27
4.1 Transmitter Connections.....	27
4.2 Installing the Sensor	28
4.3 Transmitter Cable	29
4.4 Preparation of the Sensor Cable.....	30
4.5 Installation in Hazardous Areas.....	32
5 WHICH GASES TO MEASURE?	33
6 MAINTENANCE.....	33
7 FAULT CONDITIONS	33

Figures

Figure 2.1	Process Indicator panel layout	1
Figure 2.2	Flowchart Example.....	7
Figure 3.1	Mounting the Process Indicator.....	9
Figure 3.2	AC power supply connections	11
Figure 3.3	DC power supply connections	13
Figure 3.4	Process indicator rear panel connections.....	14
Figure 3.5	Typical display	16
Figure 3.6	Change alarm switching logic.....	19
Figure 3.7	Set-up alarm levels	20
Figure 3.8	Configure analog output.....	21
Figure 3.9	Span and unit settings.....	23
Figure 3.10	Set-up alarm set-point limits.....	24
Figure 3.11	Set-up process indicator (to read ppm _v)	26
Figure 4.1	Transmitter connections	27
Figure 4.2	Pura I.S. Dew-Point Transmitter	28
Figure 4.3	Terminal block Removal.....	29
Figure 4.4	Bare wires.....	30
Figure 4.5	Crimped wires	30
Figure 4.6	Cut to 5mm.....	30
Figure 4.7	Connection to Pura I.S.TX	30
Figure 4.8	Rear of connector terminal block.....	31
Figure 4.9	Electrical Connections	31

Tables

Table 2.1	Process Indicator front panel controls and indicators	3
Table 2.2	Function keys	4
Table 2.3	Flowchart symbols	6
Table 3.1	Summary of electrical connections	15

Appendices

Appendix A	Technical Specifications	35
Appendix B	Hazardous Area Certification.....	38
	B1 Terminal Parameters	38
	B2 Special Conditions of Use	38
Appendix C	System Drawings	40
	C1 Baseefa Approved System Drawing	40
	C2 FM Approved System Drawing	41
	C3 CSA Approved System Drawing.....	42
Appendix D	List of Worldwide Michell Instruments' Offices.....	44

Safety

The manufacturer has designed this equipment to be safe when operated using the procedures detailed in this manual. The user must not use this equipment for any other purpose than that stated. Do not apply values greater than the maximum value stated.

This manual contains operating and safety instructions, which must be followed to ensure the safe operation and to maintain the equipment in a safe condition. The safety instructions are either warnings or cautions issued to protect the user and the equipment from injury or damage. Use competent personnel using good engineering practice for all procedures in this Manual.

Electrical Safety

The instrument is designed to be completely safe when used with options and accessories supplied by the manufacturer for use with the instrument.

Pressure Safety

DO NOT permit pressures greater than the safe working pressure to be applied to the instrument. The specified safe working pressure is 24 MPa (240 barg / 3480 psig).

Toxic Materials

The use of hazardous materials in the construction of this instrument has been minimized. During normal operation it is not possible for the user to come into contact with any hazardous substance which might be employed in the construction of the instrument. Care should, however, be exercised during maintenance and the disposal of certain parts.

Repair and Maintenance

The instrument must be maintained either by the manufacturer or an accredited service agent. Refer to Appendix D for details of Michell Instruments' worldwide offices' contact information.

Calibration

The recommended calibration interval for this instrument is 12 months unless it is to be used in a mission-critical application or in a dirty or contaminated environment in which case the calibration interval should be reduced accordingly. The instrument should be returned to the manufacturer, Michell Instruments Ltd., or one of their accredited service agents for re-calibration.

Safety Conformity

This product meets the essential protection requirements of the relevant EU directives. Further details of applied standards may be found in the product specification.

EU Declaration of Conformity

NOTE: The PURA I.S. product incorporates the ATEX/IECEX/CSA/FM approved Easidew I.S. product and it is the Hazardous Area Certification for the Easidew I.S. that provides the necessary approvals for the PURA I.S.

EU Declaration of Conformity



Manufacturer: **Michell Instruments Limited**
48 Lancaster Way Business Park
Ely, Cambridgeshire
CB6 3NW. UK.



On behalf of the above named company, I declare that, on the date that the equipment accompanied by this declaration is placed on the market, the equipment conforms with all technical and regulatory requirements of the directives.

PURA Premium, PURA OEM and PURA Transmitter

and complies with all the essential requirements of the EU directives listed below.

2004/108/EC EMC Directive
and (effective from 20th April 2016)
2014/30/EU EMC Directive

(effective from 22nd July 2017)

2011/65/EU Restriction of Hazardous Substances Directive (RoHS2)
RoHS2 EU Directive 2011/65/EU (Article 3, [24]) states, "*industrial monitoring and control instruments means monitoring and control instruments designed exclusively for industrial or professional use*". (mandatory compliance effective date 22nd July 2017).

and has been designed to be in conformance with the relevant sections of the following standards or other normative documents.

EN61326-1:1997	Electrical equipment for measurement, control and laboratory use – EMC requirements –Class B (emissions) and Industrial Locations (immunity).
EN61010-1:2010	Safety Requirements for Electrical Equipment for Measurement, Control, and Laboratory Use - Part 1: General Requirements

Andrew M.V. Stokes, Technical Director

April 2016

EUD PURA Issue 02

Abbreviations

The following abbreviations are used in this Manual:

AC	alternating current
atm	pressure unit (atmosphere)
barg	pressure unit (=100 kP or 0.987 atm)
°C	degrees Celsius
°F	degrees Fahrenheit
DC	direct current
ft	foot (feet)
g	gram(s)
Hz	Hertz
"	inch(es)
kg	kilogram(s)
lb	pound
NI/min	normal liters per minute
m	meter(s)
mA	milliampere
max	maximum
min	minute(s)
mm	millimeter(s)
MPa	megapascal (Pascals x10 ⁶)
m/sec	meters per second
Nm	Newton meter
ppm _v	parts per million (by volume)
RS232	serial data transmission standard
Rx	receive
scfh	standard cubic feet per hour
scfs	standard cubic feet per second
sec	second(s)
temp	temperature
Tx	transmit
V	Volts
Ω	Ohms

Warnings

The following general warnings listed below are applicable to this instrument. They are repeated in the text in the appropriate locations.



Where this hazard warning symbol appears in the following sections it is used to indicate areas where potentially hazardous operations need to be carried out.

Recycling Policy



Michell Instruments is concerned with the protection of the environment. It is our commitment to reduce and eliminate from our operations, wherever possible, the use of substances which may be harmful to the environment. Similarly, we are increasingly using recyclable and/or recycled material in our business and products wherever it is practical to do so.

The product that you have purchased may contain recyclable and/or recycled parts and we will be happy to provide you with information on these components if required.

WEEE And RoHS Compliance

The Waste Electronic and Electrical Equipment (WEEE) Directive, and the Restriction of Hazardous Substances (RoHS) Directive place rules upon European manufacturers of electrical and electronic equipment. The directive's aim is to reduce the impact that electronic devices have on the environment.

Michell products are currently exempt from the RoHS directive, however all future products will be developed entirely using compliant materials. Furthermore, Michell is taking active steps to remove non-compliant materials and components from existing products wherever possible.

Michell is in full compliance with the WEEE Directive (Registration No. WEE/JB0235YW). Customers may be required to return certain instruments for treatment at the end of their working life.

June 2010

Calibration Facilities

Michell Instruments' calibration facilities are among the most sophisticated in the world and have been recognized for their excellence.

Traceability to the National Physical Laboratory (NPL) UK is achieved through our UKAS Accreditation (Number 0179). This covers dew point over the range -90 to +90°C (-130 to +194°F) and also Relative Humidity.

Dew-point calibrations are also traceable to the National Institute for Standards & Technology (NIST) USA over the range -75 to +20°C (-103 to +68°F).

NOTE: Standard traceable calibration certificates for instruments and sensors are not issued under our UKAS accreditation. UKAS certificates are usually to special order and are clearly identified.

Manufacturing Quality

Michell Instruments is registered with the British Standards Institute for Quality Assurance to:

BS EN ISO 9001: 2008

Rigorous procedures are performed at every stage of production to ensure that the materials of construction, manufacturing, calibration and final test procedures meet the requirements laid down by our BSI approved Quality System.

Please contact Michell Instruments if the product does not arrive in perfect working order.

Warranty

Unless otherwise agreed, the Supplier warrants that, as from the date of delivery for a period of 12 months, the goods and all their component parts, where applicable, are free from any defects in design, workmanship, construction or materials.

The Supplier warrants that the services undertaken shall be performed using reasonable skill and care, and of a quality conforming to generally accepted industry standards and practices.

Except as expressly stated all warranties, whether express or implied, by operation of law or otherwise, are hereby excluded in relation to the goods and services to be provided by the Supplier.

All warranty services are provided on a return to base basis. Any transportation costs for the return of a warranty claim shall reside with the Customer.

Return Policy

If a Michell Instruments' product malfunctions within the warranty period, the following procedure must be completed:

1. Notify a Michell Instruments' representative, giving full details of the problem, the model variant and the serial number of the product.
2. If the nature of the problem indicates the need for factory service then the instrument should be returned to Michell Instruments, carriage prepaid, preferably in the original packaging, **with a full description of the fault and the customer contact information.**
3. Upon receipt, Michell Instruments will evaluate the product to determine the cause of the malfunction. Then, one of the following courses of action will be taken:
 - If the fault is covered under the terms of the warranty, the instrument will be repaired at no cost to the owner and returned.
 - If Michell Instruments determines that the fault is not covered under the terms of the warranty, or if the warranty has expired, an estimate for the cost of the repairs, at standard rates, will be provided. Upon receipt of the owner's approval to proceed, the product will be repaired and returned.

1 INTRODUCTION

The Pura Hazardous Area Online Hygrometer is a continuous, on-line instrument for the measurement of moisture content in a gas, over the operating range of -120 to -40°Cdp (-184 to -40°Fdp) and equivalent units (see Technical Specifications, Appendix A). The Pura Hygrometer utilizes the Pura I.S. Intrinsicly Safe Dew-Point Transmitter as the sensor, coupled with the Pura Online Monitor as the display unit. Dual alarm relay contacts are provided which are user-configurable, both in terms of set-point and operating mode. Current output is standard and factory set at 4-20 mA.

2 DESCRIPTION

The controls and indicators associated with the Pura Hygrometer are located on the front panel of the Process Indicator.

Connections to the Pura I.S. Transmitter, the RS232 communications port and the external power supply are all made to the rear panel of the Process Indicator (refer to Sections 3 and 4).

Figure 2.1 shows the layout of these controls and Tables 2.1 and 2.2 describe their respective operational functions.



Figure 2.1 Process Indicator panel layout

2.1 Display

The instrument has a 4-digit display, set-up on delivery to display a dew-point temperature range of -40°Cdp (-40°Fdp) (corresponding to a transmitter input of 20 mA), to -120°Cdp (-184°Fdp) (corresponding to a transmitter input of 4 mA). Negative temperature readings are signed.

Temperature units are displayed by one of the two LED's located to the left of the display. On delivery, $^{\circ}\text{Cdp}$ is set-up. If required, the units can be changed to $^{\circ}\text{Fdp}$. The method of configuring the unit for $^{\circ}\text{Fdp}$ is described in Section 3.7.

If the sensor is scaled to output ppm_v then the instrument can be set-up to read dew point in parts per million (ppm_v). This option requires the transmitter to be set-up for ppm_v either at the time of ordering, or subsequently via Michell application software. **Note: No specific ppm_v LED indicator is provided on the Process Indicator; ppm_v is selected if neither the $^{\circ}\text{Cdp}$ nor the $^{\circ}\text{Fdp}$ temperature indicators are illuminated.**

Two temperature alarm indications are provided by two LEDs located on the right hand side of the display, AL1 (low) and AL2 (high). Access to the alarm relay contacts is provided on the rear panel. The connection for these alarm relay contacts is shown in Section 3.4.

The operating temperature at which these alarm outputs operate is set-up as shown in Section 3.6.2.

Item	Description
1	<p>°Fdp</p> <p>When illuminated, this LED indicates that the displayed dew-point reading is in degrees Fahrenheit.</p> <p>Note: If neither the °Fdp or °Cdp LED is lit, ppm_v is selected.</p>
2	<p>°Cdp</p> <p>When illuminated, this LED indicates that the displayed dew-point reading is in degrees Celsius.</p> <p>Note: if neither the °Cdp nor °Fdp LED is lit, ppm_v is selected.</p>
3	<p>Main dew-point temperature display</p> <p>Flashes to alternately indicate 'ErrL' (error low) and temperature reading for low temperatures under-range (lower than -120°Cdp (-184°Fdp) or -129.9°Cdp (199.9°Fdp) for an open loop condition).</p> <p>Flashes to alternately indicate 'ErrH' (error high) and temperature reading for high temperature over-range.</p>
4	<p>AL1</p> <p>When illuminated, this LED indicates that the dew-point temperature programmed for Alarm 1 has exceeded the programmed threshold. Under these conditions the alarm relay contacts associated with this alarm (normally open) will change state (close) and will remain closed until the dew-point temperature moves back within the programmed operational limit.</p> <p>Alarm 1 is usually allocated to the Low Alarm setting.</p> <p>These relay contacts are rated at 250 V, 3 A and are connected as shown in Section 3.4.</p> <p>Section 3.6.2 describes the setting up of AL1 trip points.</p>
5	<p>AL2</p> <p>When illuminated this LED indicates that the dew-point temperature programmed for Alarm 2 has exceeded the programmed threshold. Under these conditions the alarm relay changeover contacts associated with this alarm will change state and will remain in this state until the temperature moves back to within the programmed operational limit.</p> <p>Alarm 2 is usually allocated to the High Alarm setting.</p> <p>These changeover relay contacts are rated at 250 V, 5 A and are connected as shown in Section 3.4.</p> <p>Section 3.6.2 describes the setting up of AL2 trip points.</p>

Table 2.1 Process Indicator front panel controls and indicators

2.2 Function Keys

The four function keys, located below the display, are used for setting up the Process Indicator.

The following set-up functions are covered in Section 3 of this Manual:

- Reversal of alarm level switching logic
- Set-up alarm level trip points for AL1 and AL2
- Selection of temperature units
- Selection of re-transmission output current loop range, either 4-20 mA or 0-20 mA
- Set-up/change operating temperature range or ppm_v range

The function key panel is shown in *Figure 2.1*. Table 2.2 describes the operation of the keys.





Item	Description
	<p>'P' (Program) key</p> <p>This key is used to access the programming menus and to select sub-menus within the list.</p>
	<p>'←' Left arrow (decrement) key</p> <p>This key is used to access sub-menus and, within individual sub-menus, to decrease the numeric value of the selected parameter.</p>
	<p>'→' Right arrow (increment) key</p> <p>This key is used to access sub-menus and, within individual sub-menus, to increase the numeric value of the selected parameter.</p>
	<p>'SET' key</p> <p>Depending upon the context, this key is used to access the set value of the selected process field or as an 'Accept' key for new parameter values.</p>

Table 2.2 Function keys

2.3 Process Indicator Menu Structure

Once the Pura Hygrometer is set-up it should not require much adjustment. The dew-point transmitter is supplied, as standard, with a linear output in the range of 4-20 mA (corresponding to -120°Cdp (-184°Fdp) and -40°Cdp (-40°Fdp) respectively).

As supplied, the Process Indicator is configured to accept this 4-20 mA input, to indicate the measured dew-point temperature in $^{\circ}\text{C}$ and to give over-range indications with a flashing display if the operational limits are exceeded.

Alarm level set-points are pre-set. The default settings are -20°Cdp for Alarm 1 and -40°Cdp for Alarm 2.

For most applications the default parameters are usually sufficient but programming facilities within the Process Indicator permit the changing of some parameters.

These parameters, such as alarm levels, alarm switching logic, temperature units and analog re-transmission current loop output range are set-up under a menu structure and are accessed by pressing the programming key 'P' on the Process Indicator's control panel.



This Manual describes the functions relating to the operational requirements of the Pura Hygrometer equipment and it is not recommended that menu structures other than those described be entered.

NOTE: If a sub-menu is entered by mistake, quit by pressing the 'P' key until the main display is restored. Never try to quit with the 'SET' key.

Section 3 describes the set-up procedures. The flowcharts shown in Section 3 use the symbols from Table 2.3.







Symbol	Description
	Display reading / Indication Outline is shown as solid green if the display is static
	Display reading / Indication Outline is shown as solid red if the display is flashing
	Display Outline is shown as red, dashed, to indicate that the display is alternately flashing between the two indicated values
	Indicates the requirement to press the 'P' program key. Any number next to the key indicates the number of times to press the key, e.g. 6
	Indicates the requirement to press the 'SET' key. Any number next to the key indicates the number of times to press the key, e.g. 6
	Indicates the requirement to press the increment '⇨' key.
	Indicates the requirement to press the decrement '⇦' key.

Table 2.3 Flowchart symbols

2.3.1 Flowchart Reading Method

Figure 2.2 shows a typical flowchart for setting up the alarm switching levels and shows how to change the default settings for AL1 from -20°Cdp to -25.5°Cdp and for AL2 from -40°Cdp to -50°Cdp.

This, and all subsequent flowcharts in other sections, should be read from top to bottom, left to right.

Further details on alarm settings are given in Section 3.

2.3.2 Flowchart Example

The following is a flowchart example showing the set-up of alarm levels. For actual set-up instructions see Section 3.6.2.

The alarm set-point levels are set-up from the program menu as follows:

To set-up both alarm set-points

1. Press the 'SET' key once. 'ALr1' will be displayed shown with a green outline to indicate that the display is static. (To set Alarm 2, press the 'SET' key two times and follow the Alarm 2 branch instead).
2. Press the '⇒' key to display the current Alarm 1 set-point (-20°C in this example). This is shown with a red outline and is flashing.
3. Use the '⇒' and '⇐' keys to set the required value (-25.5°C in this example). This is shown with a red outline and is flashing.
4. **To exit to the main display without saving any new setting, press the 'P' key.**
5. Press the 'SET' key once to store the new (or existing) value for Alarm 1 and to enter the set-up menu for Alarm 2. 'ALr2' will now be displayed. This is shown with a green outline and is static. Press the 'P' key to exit if setting Alarm 1 only.
6. Press the '⇒' key to display the current Alarm 2 set-point (-40°C in this example). This is shown with a red outline and is flashing.
7. Use the '⇒' and '⇐' keys to set the required value (-50°C in this example) This is shown with a red outline and is flashing.
8. Press the 'SET' key once to store the new value for Alarm 2. The display will then return to the main dew-point temperature display.

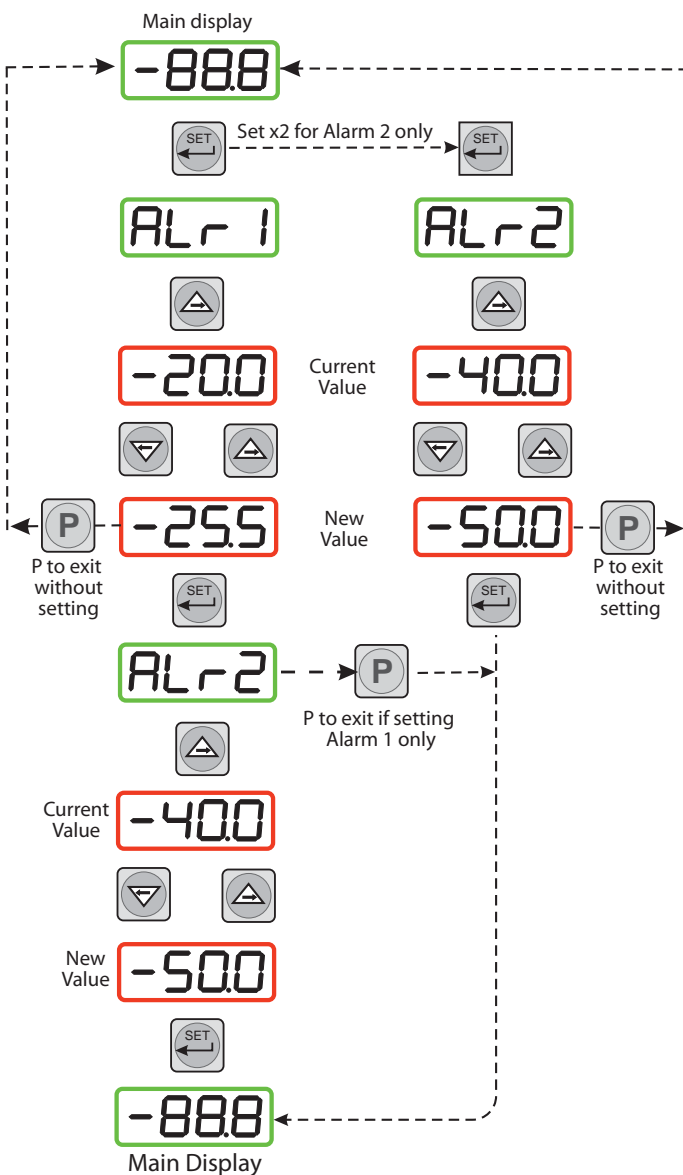

Figure 2.2 Flowchart Example

3 OPERATION

3.1 Operational Requirements

The following operational requirements are required:

3.1.1 Environmental Requirements – Process Indicator

Operating temperature range:	0 to +50°C (+32 to +122°F)
Humidity:	90% RH (non-condensing)
Altitude:	Up to 2000m

3.1.2 Electrical Requirements

Supply voltage: 100 V to 240 V AC (+10%, -15%), 50/60 Hz, 6 VA

Transmitter supply: 12 V to 28 V DC (25 mA max)*

*Current loop excitation supply, 24 V DC (supplied by the Process Indicator)

3.2 Mounting the Process Indicator

The Process Indicator is designed for panel mounting and requires a panel cut-out of 46 x 92mm (1.8 x 3.6"). The recommended panel thickness is 2 to 5mm (0.08 to 0.2").

To mount the unit, proceed as follows (refer to *Figure 3.1*):

1. Pass the Process Indicator (1) through the front of the panel (2).
2. Support the Process Indicator and insert the hook on the underside of the clamp (3) into the slot (4) located on top of the Process Indicator casing.
3. Tighten the fixing screw (5) finger tight, against the back of the panel.
4. Insert the hook on the second clamp (6) into the slot located on the underside of the instrument casing and tighten the fixing screw, finger tight, against the back of the panel.
5. Ensure that the Process Indicator is sitting flush to the front of the panel (2) and tighten the fixing screws evenly against the back of the panel.



Caution: Do not overtighten the screws as this could cause the case to crack.

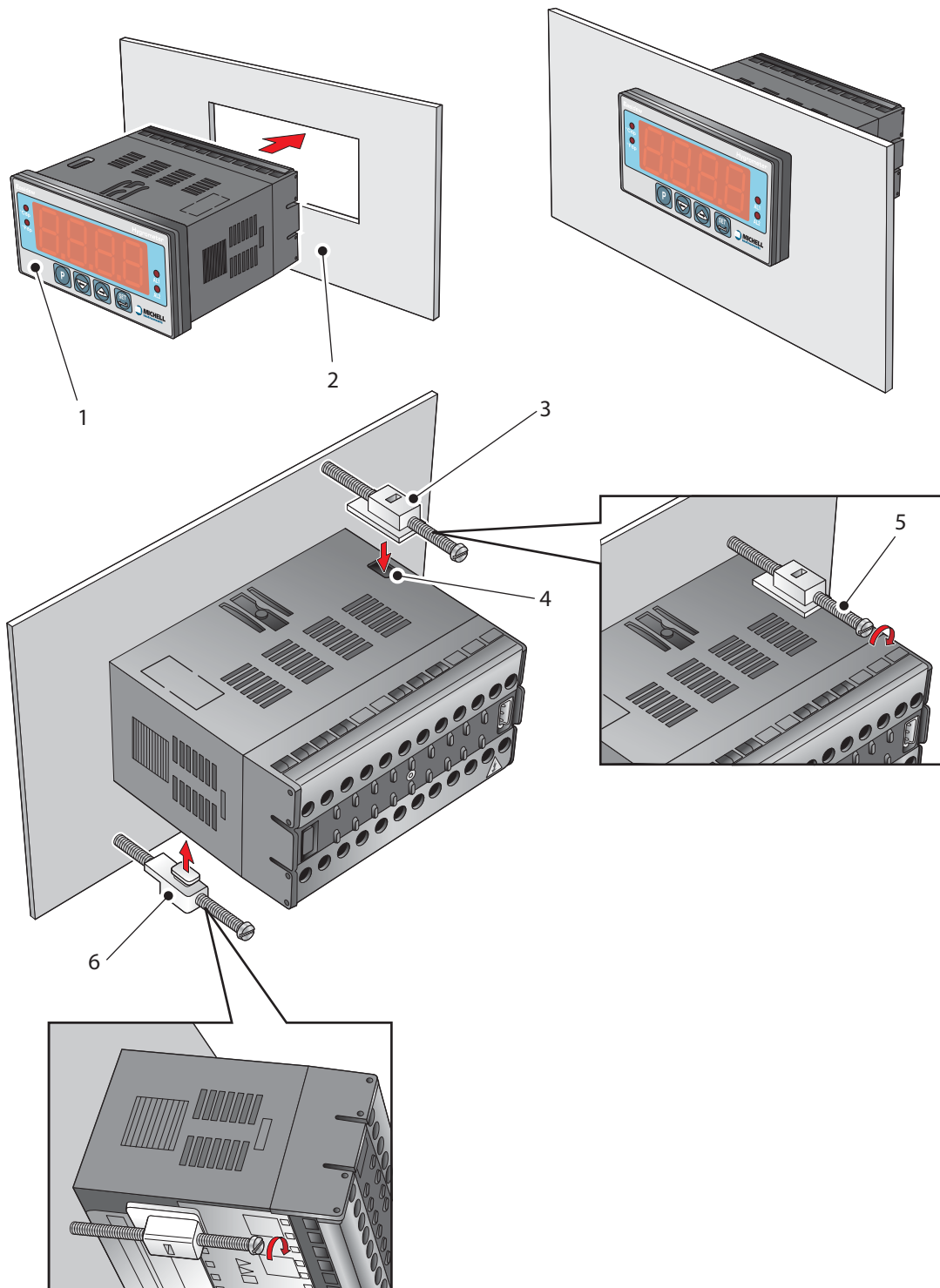

Figure 3.1 Mounting the Process Indicator

3.3 Electrical Connections

Electrical connections to the Pura Hygrometer system are as follows:

- AC power supply, 100 V to 240 V AC (+10%, -15%), 50/60 Hz, 6 VA. A low voltage (24 V DC) option is also available.
- Transmitter current loop input, 4-20 mA (24 V DC loop power provided by Process Indicator).
- Alarm 1 (Low), potential free contacts, single pole make. Contacts rated at 250 V, 5 A.
- Alarm 2 (High), potential free contacts, single pole changeover. Contacts rated at 250 V, 5 A.
- Re-transmitted dew-point input signal 4-20 mA or 0-20 mA.

3.3.1 AC Power Supply Input



It is essential that the connection of electrical supplies to this instrument be undertaken by competent personnel

Connect the AC power supply to the Process Indicator (1) as shown in *Figure 3.2*. Refer also to Table 3.1 which gives a summary of all the connections to the rear panel of the Process Indicator.

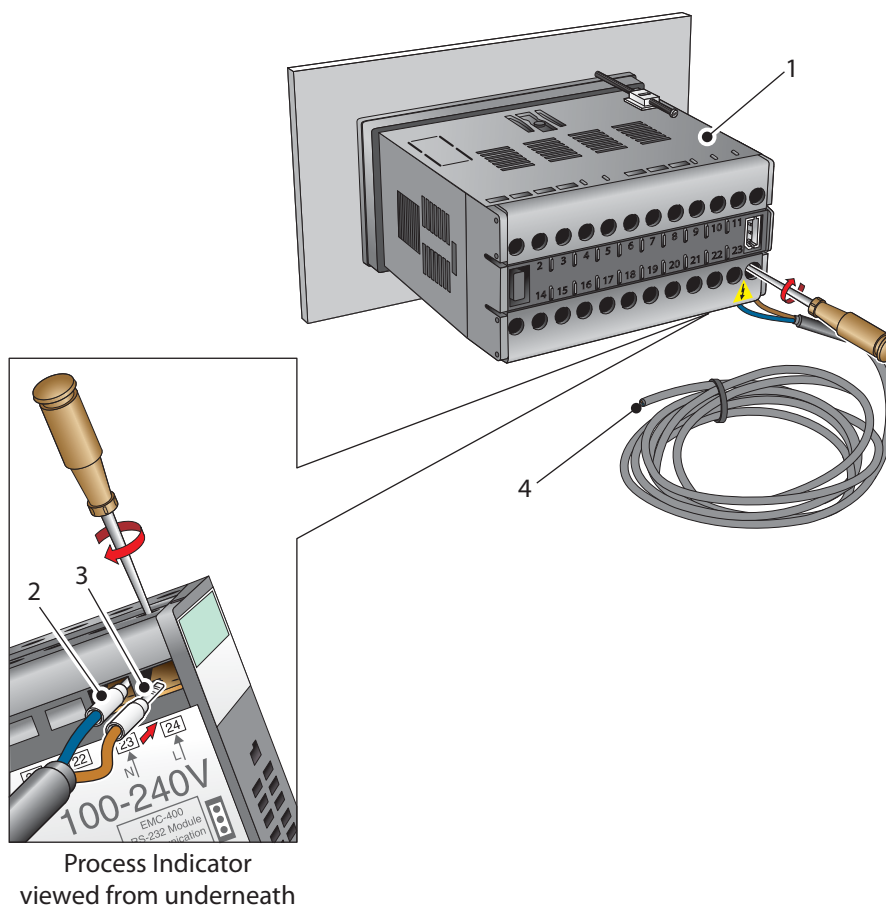

Figure 3.2 AC power supply connections

1. Ensure that no power is connected to the mains lead.
2. Connect the blue (white - US standard) (neutral) lead (2) to terminal 23 on the rear panel of the Process Indicator.
3. Connect the brown (black - US standard) (live) lead (3) to terminal 24 on the rear panel of the Process Indicator.
4. Strip back the insulation on the free end of the power cable and wire to an appropriate power supply plug (brown lead to live supply terminal, blue lead to neutral supply terminal).
5. Check that the wiring has been completed correctly before connecting to a mains power supply.

3.3.2 Preliminary System Test

Before wiring the external signal outputs and the transmitter, perform a system check as follows:

1. Switch off and disconnect the power supply.
2. Connect to an AC supply and switch the supply ON. The Process Indicator display should come on. The display digits are sequentially tested, each in turn displaying the figure '8'. With no transmitter connected (current loop open), the display will be alternately flashing 'ErrL' and '-154.9'. The °Cdp LED will, by default, also be illuminated and it is possible, that even though no alarms are currently set-up, one of the alarm LED's may be illuminated. **NOTE: If the instrument is configured to read ppm_v, neither of the temperature LED indicators will be lit.**
3. If a loop calibrator is available, set it to Ext loop and connect to terminal 4 (positive) and terminal 3 (negative) of the Process Indicator.
4. Set the output current of the loop calibrator to 4 mA, the display should now be reading -120.0.
5. Set the output current of the loop calibrator to 20 mA, the display should now be reading -040.0.
6. Switch off and disconnect the loop calibrator.
7. Connect the transmitter as described in Section 4.1

3.3.3 DC Power Supply Input (Optional)

Connect the DC power supply to the Process Indicator (1) as shown in *Figure 3.3*. Refer also to Table 3.1 which gives a summary of all the connections to the rear panel of the Process Indicator.

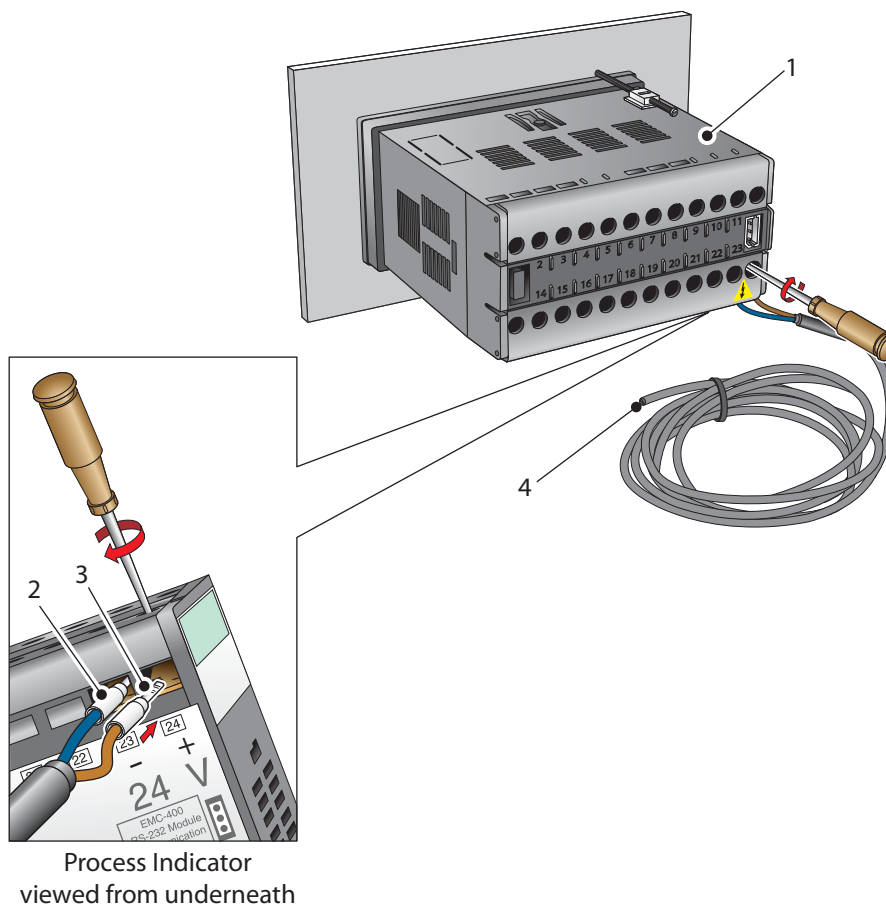

Figure 3.3 DC power supply connections

1. Ensure that no power is connected to the mains lead.
2. Connect the blue (white - US standard) lead (2) to terminal 23 on the rear panel of the Process Indicator.
3. Connect the brown (black - US standard) lead (3) to terminal 24 on the rear panel of the Process Indicator.
4. Strip back the insulation on the free end of the power cable and wire to an appropriate power supply plug (brown lead to positive (+) supply terminal, blue lead to negative (-) supply terminal).
5. Check that the wiring has been completed correctly before connecting to a mains power supply.

3.4 Signal Output Connections

The Pura Hygrometer system has three signal outputs, Alarm 1 (ALr1), Alarm 2 (ALr2) and the re-transmitted input signal (4-20 mA or 0-20 mA current loop signal depending upon instrument configuration).

Figure 3.4 shows the relevant rear panel connections. Table 3.1 shows a summary of all the electrical connections to the Process Indicator.



The signal outputs will be connected to external systems that can potentially influence the operation of the process.

Alarm level signals could be at mains potential so it is essential that, before connecting these signal lines, checks are made to ensure that these inputs are not live and that it is safe to handle them.

Re-transmission Output

The re-transmission output is current sourcing. Connect the positive output to terminal 14 and the negative output to terminal 13. Use appropriately colored wires e.g., red (positive), black (negative).

Alarm Outputs

Alarm 1 is a single pole make contact. Connect incoming signal lines to terminal 16 (common) and terminal 17 (normally open).

Alarm 2 comprises a set of changeover contacts. Connect incoming signal lines to terminal 9 (common), terminal 8 (normally open) and terminal 7 (normally closed).

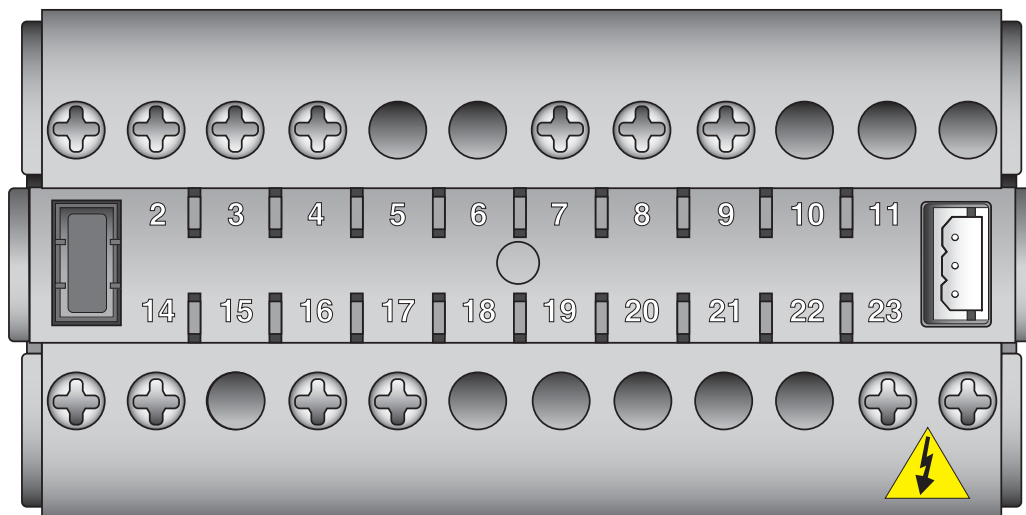

Figure 3.4 Process indicator rear panel connections

Terminal	Wire Color	Signal	Supply Information
1	Blue	0 V (GND)	
3	Green	4-20 mA loop current	Default 4-20 mA
4	Red	Transmitter loop supply (+ve)	+24 V DC w.r.t. terminal 1
7	User defined	ALR2 (normally closed)	
8	User defined	ALR2 (normally open)	
9	User defined	ALR 2 (common)	
13	User defined	Current loop out (-ve)	Default 4-20 mA
14	User defined	Current loop out (+ve)	Default 4-20 mA
16	User defined	ALR1 (common)	
17	User defined	ALR2 (normally open)	
23 (AC Version)	Blue	Power in (neutral)	100 – 240 V, 50/60 Hz
24 (AC Version)	Brown	Power in (live)	100 – 240 V, 50/60 Hz
23 (DC Version)	Blue	Negative (-)	0 V
24 (DC Version)	Brown	Positive (+)	24 V
<p>NOTE: There are no terminals in positions 5, 6, 10, 11, 12, 15, 18, 19, 20, 21 and 22</p>			

Table 3.1 Summary of electrical connections

3.5 First Time Operation

Prior to operation, the instrument must be connected to the correct electrical power supply and the relevant analog and alarm outputs connected to external systems as required and as described above.

To commence operation, proceed as follows:

1. Switch on the power supply to the instrument. The instrument display will now come on, typically showing the default parameters and units as detailed in *Figure 3.5*.
2. Check that the gas sample flow rate through the sample block or the pipeline in which the transmitter is located is within the operational limits:
1 to 10 NI/min (2.1 to 21.2 scfh) (5 NI/min (10.6 scfh) optimum)
3. Adjust any external flow control valves, located in the gas sample input line to the instrument, to achieve the required flow rate.

The instrument is now operational and after a few seconds, in which all the segments of the display are tested, the process indicator will display the measured dew-point temperature as a steady reading within the range -120 to -40°Cdp (-184 to -40°Fdp), depending upon how the instrument has been set-up. The default setting is degrees Celsius.

In the absence of any error indications the instrument will now be operational using the default parameters, typically as shown in *Figure 3.5*.



Figure 3.5 Typical display

If the display is flashing, a fault condition exists.

The following operational error conditions may be encountered:

- **'ErrL'** If the display is alternately flashing (e.g.) **'ErrL'** and **'-120.3'**, this indicates that the measured dew point is outside the lower operational limit (-120°Cdp) and the numeric section of the display gives an indication of the actual measured reading.
- If the display is alternately flashing **'ErrL'** and **'-154.9'**, (or **'-199.9'** if set-up to read temperature in °F), this could be an indication that the input current loop to the process indicator is open or that there may be a transmitter fault. Check that the transmitter is wired correctly as detailed in Section 4.1.
- **'ErrH'** If the display is alternately flashing (e.g.) **'ErrH'** and **'-39.9'**, this indicates that the measured dew point is outside the upper operational limit (-40°Cdp) and the numeric section of the display gives an indication of the actual measured reading.

3.6 System Alarms

The Pura Hygrometer has two alarm outputs. As supplied, the default alarm set-points and the alarm switching logic are as follows (the default temperature units are degrees Celsius):

- Low Alarm - Alarm 1 (**AL1**) set to -20°Cdp
- High Alarm - Alarm 2 (**AL2**) set to -40°Cdp

Alarm 1 (Low Alarm) is set-up to switch ON when the temperature reading is lower (gas drier) than the alarm set-point value. For the default set-points therefore, the default switching logic for these alarms is as follows:

- Alarm 1 Temp < -20 Alarm 1 = ON
- Temp > -20 Alarm 1 = OFF

Alarm 2 (High Alarm) is set to switch ON when the temperature reading is higher (gas wetter) than its set-point value. For the default set-points therefore, the operation of this alarm would be as follows:

- Alarm 2 Temp < -40 Alarm 2 = OFF
- Temp > -40 Alarm 2 = ON

Depending upon the application, if required, it is possible to reverse the switching logic for either or both of the alarm channel outputs to provide the following alarm output configurations.

- Alarm 1 Temp < -20 Alarm 1 = OFF
- Temp > -20 Alarm 1 = ON
- Alarm 2 Temp < -40 Alarm 2 = ON
- Temp > -40 Alarm 2 = OFF

Section 3.6.1 describes the method for reversing the default switching logic and Section 3.6.2 describes the method for setting up individual alarm set-points.

3.6.1 Reversal of Default Alarm Switching Logic

As stated in Section 3.6, the switching logic for the alarm channels may, if required, be individually reversed. Starting at the default state, the method of reversing the switching logic for both alarms is as follows:

Figure 3.6 shows the operational key sequence.

For Alarm 1:

1. Press the 'P' key once and the display will read 'tECH'.
2. Press the 'SET' key and the display will flash between 'ConF' and 'PinP'.
3. Press the '⇒' key twice and the display will flash between 'ConF' and 'Alr1'.
4. Press the 'SET' key twice to display 'Alt1'.
5. Press the '⇒' key once to display a flashing 4 digit number. For the Alarm 1 default setting this will be 0001.
6. Press the '⇐' key once to change the display to 0000.
7. Press the 'SET' key to accept the new value. The default setting for Alarm 1 is now reversed.
8. Either press the 'P' key twice to return to the main display or press the 'P' key once followed by the '⇒' key to move to the 'Alr2' setting sequence from step 4 above.

To reverse the switching logic for Alarm 2 ONLY, proceed as follows:

1. Press the 'P' key once and the display will read 'tECH'.
2. Press the 'SET' key and the display will flash between 'ConF' and 'PinP'.
3. Press the '⇒' key three times and the display will flash between 'ConF' and 'Alr2'.
4. Press the 'SET' key twice to display 'Alt2'.
5. Press the '⇒' key once to display a flashing 4 digit number. For the Alarm 2 default setting this will be 0000.
6. Press the '⇒' key once to change the display to 0001.
7. Press the 'SET' key to store the new value.
8. Press the 'P' key twice to return to the main display. The default setting for Alarm 2 is now reversed.

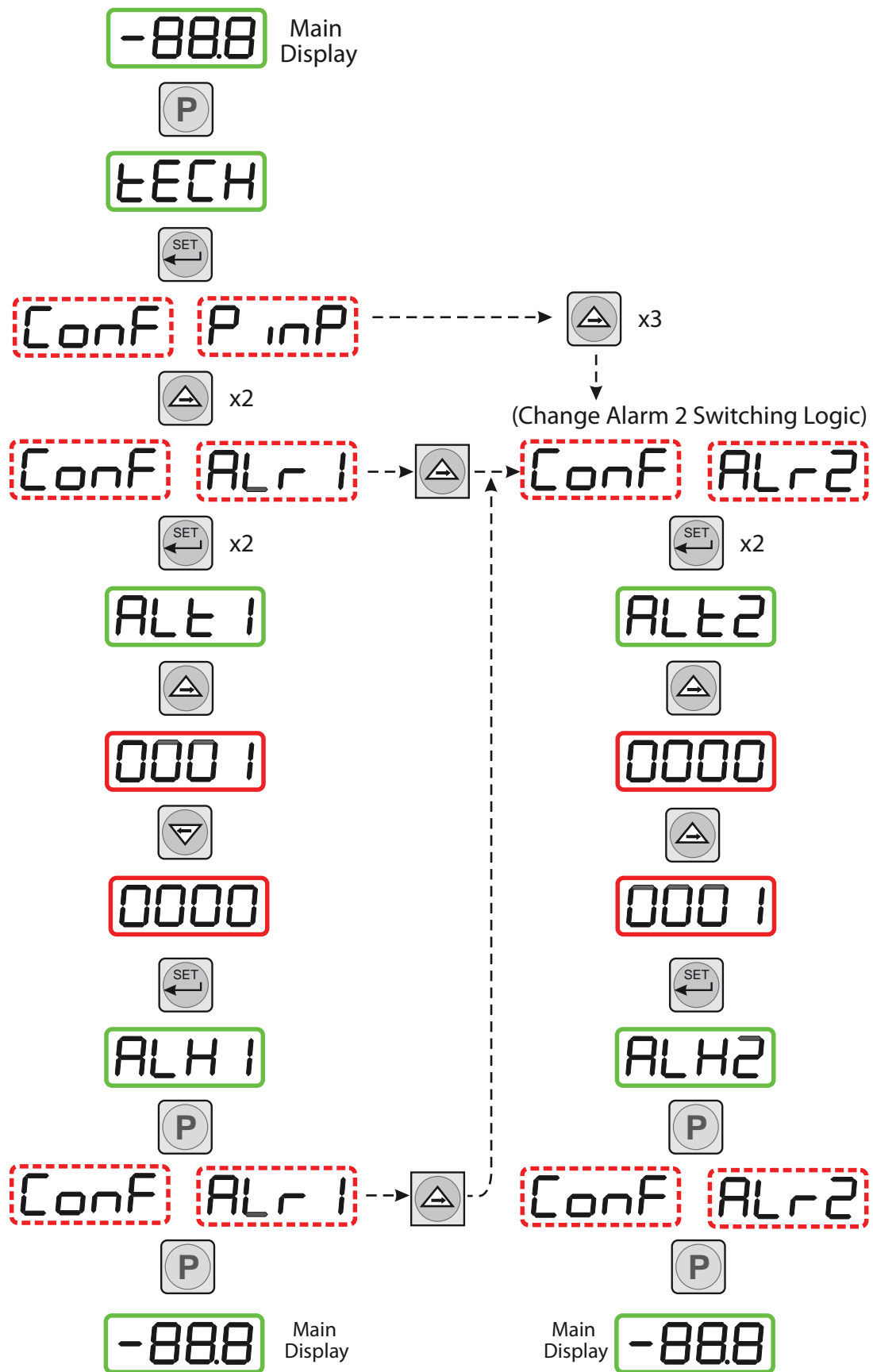

Figure 3.6 Change alarm switching logic

3.6.2 Set-up Alarm Levels

The alarm set-point levels are set-up from the program menu as follows (to exit to the main display without saving any new settings press the 'P' key):

Figure 3.7 shows the operational key sequence.

To set-up both alarm set-points:

1. Press the 'SET' key once, 'ALr1' will be displayed. (To set Alarm 2 only, press the 'SET' key twice and follow the Alarm 2 branch instead).
2. Press the '⇒' key to display the flashing current Alarm 1 set-point (-20°C in this example).
3. Use the '⇒' and '⇐' keys to set the required value (-25.5°C in this example).
4. Press the 'SET' key once to store the new (or existing) value for Alarm 1 and to enter the set-up menu for Alarm 2, 'ALr2'. (To exit to the main display without changing Alarm 2 set-point levels, press the 'P' key.)
5. Press the '⇒' key to display the flashing current Alarm 2 set-point (-40°C in this example).
6. Use the '⇒' and '⇐' keys to set the required value (-50°C in this example).
7. Press the 'SET' key once to store the new value for Alarm 2. The display then returns to the main dew-point temperature display.

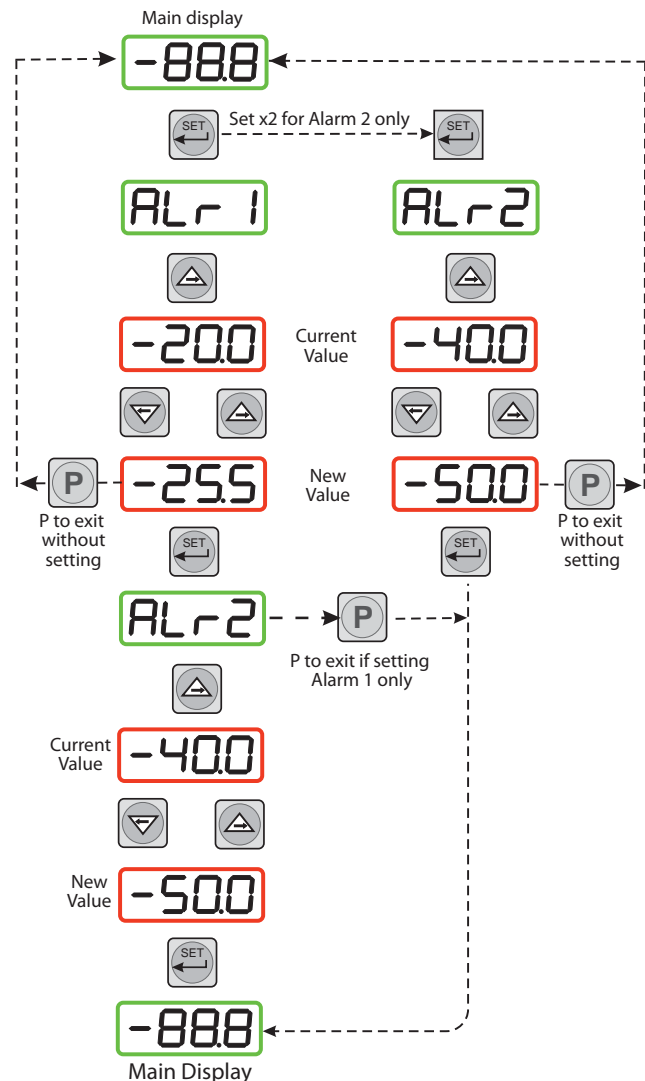

Figure 3.7 Set-up alarm levels

3.6.3 Configure Analog Output Current Loop

The Pura Hygrometer is provided with an analog current loop output module which buffers and re-transmits the current loop input signal from the dew-point transmitter.

By default, the re-transmission output is set as a 4-20 mA current loop (to exactly follow the input signal, i.e. 4 mA in, 4 mA out).

For certain system processes, a 0-20 mA current loop output may be required. The set-up method is as follows:

Figure 3.8 shows the operational key sequence.

Change output from 4-20 mA to 0-20 mA

1. Press the 'P' key once, the display will read 'tECH'.
2. Press the 'SET' key and the display will flash between 'ConF' and 'PinP'.
3. Press the '⇒' key and the display will flash between 'out1' and 'ConF'.
4. Press the 'SET' key to display 'oAt1'.
5. Press the '⇒' key once to display a flashing 4 digit number. For the default setting (4-20 mA) this will be 0001.
6. Press the '⇐' key once to change the display to 0000. This selects the re-transmission output to be 0-20 mA.
7. Press the 'SET' key to accept the new value. The output current loop is now 0-20 mA. The display will flash between 'out1' and 'ConF'.
8. Press the 'P' key once to return to the main dew-point temperature display,

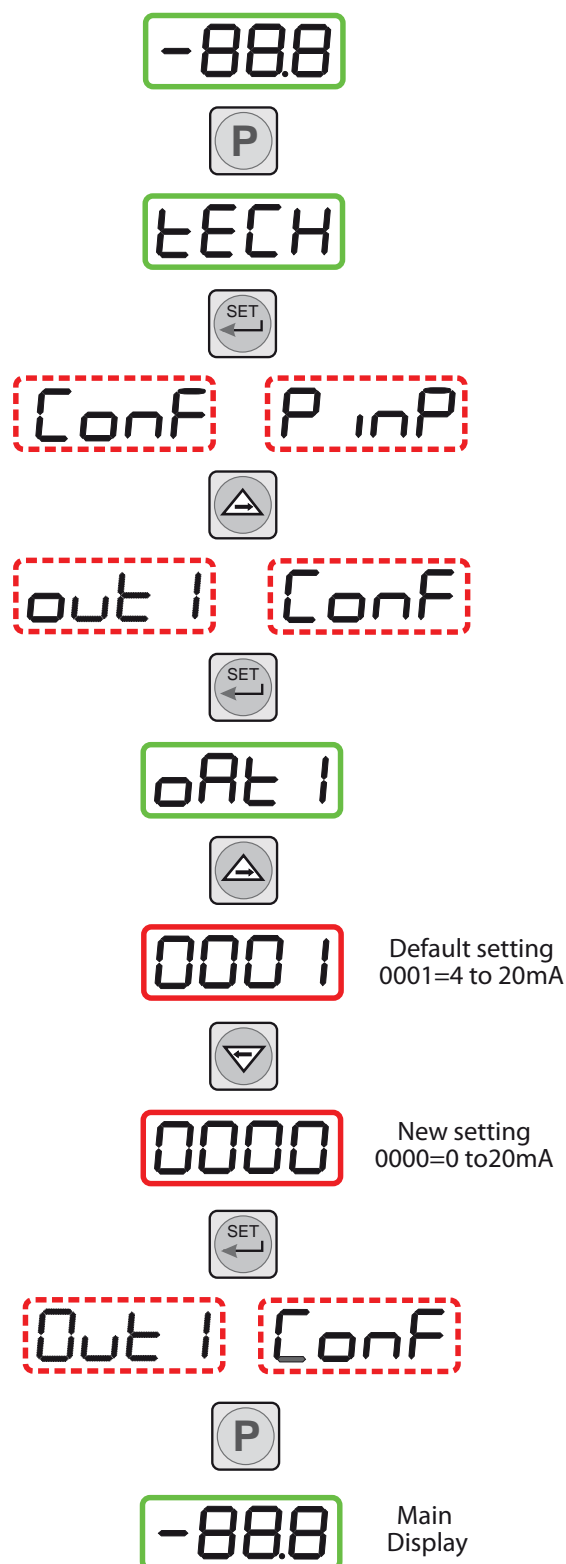

Figure 3.8 Configure analog output

3.7 Change Dew-Point Temperature Range

The default temperature unit for the Pura Hygrometer is degrees Celsius. This is indicated by the °Cdp LED indicator. The default settings associated with this temperature scale are as follows:

- Span -40 to -120°Cdp
- Upper and lower span limits -40 and -120 (display flashes outside this range)
- Minimum alarm set-point -120°Cdp
- Maximum alarm set-point -40°Cdp



To range the instrument for °F, all the above parameters need to be changed to their Fahrenheit equivalent values (-40 and -184°F). It is not sufficient just to change the units.

After these parameters have been changed, the alarm level set-points will remain set at their previous levels -40 and -20 but will now represent °F. These will therefore probably require changing, refer to Section 3.7.2 for details.

3.7.1 Span and Unit Settings

To change the span and unit settings, proceed as follows. *Figure 3.9* shows the operational key sequence.

1. Press the 'P' key once, the display will read 'tECH'.
2. Press the 'SET' key six times and the display will read 'tPoL'.
3. Press the '⇒' key and the display will flash with the current minimum span limit (-100.0).
4. Use the '⇒' and '⇐' keys to set the required equivalent Fahrenheit value (-148.0) and press the 'SET' key. 'tPoH' is then displayed.
5. Press the '⇒' key, the display will flash the current maximum span limit (020.0).
6. Use the '⇒' and '⇐' keys to set the required equivalent Fahrenheit value (068.0) and press the 'SET' key twice. 'uPL' is then displayed.
7. Press the '⇒' key, the display will flash with the current unit (°C).
8. Use the '⇒' and '⇐' keys to set the required scale units (°F in this example) and press the 'SET' key. 'PUoF' is then displayed.
9. Press the '⇒' key and the display will flash with the current alarm lower range limit (-100.0).
10. Use the '⇒' and '⇐' keys to set the required equivalent Fahrenheit value (-148) and press the 'SET' key. 'uPL' is then displayed.
11. Press the '⇒' key, the display will flash the current alarm upper range limit (020.0).
12. Use the '⇒' and '⇐' keys to set the required equivalent Fahrenheit value (068.0) and press the 'SET' key. 'PUoF' is then displayed. Press the 'P' key twice to return to the main menu.
13. The maximum and minimum alarm level limits should now be changed to suit the new (Fahrenheit) unit values (refer to Section 3.6.2).

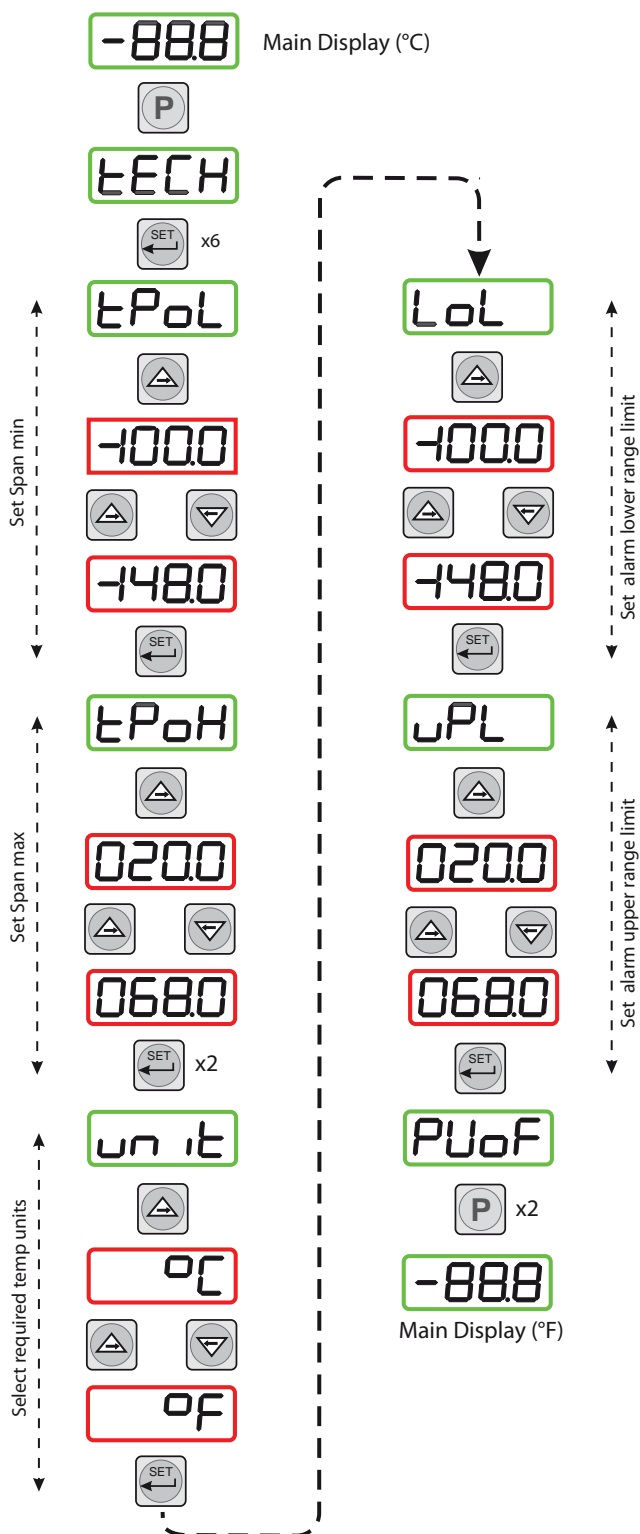

Figure 3.9 Span and unit settings

3.7.2 Configure Alarm Set-Point Limits

The following procedure is used to set limits to which the alarm levels can be set (usually after re-configuring the instrument's range for Fahrenheit readings).

Figure 3.10 shows the operational key sequence.

1. Press the 'P' key once, the display will read 'tECH'.
2. Press the 'SET' key once and the display will flash between 'ConF' and 'PinP'.
3. Press the '⇨' key four times and the display will flash between 'ConF' and 'GEnn'.
4. Press the 'SET' key once, the display will read 'SU-L'.
5. Press the '⇨' key once to display a flashing 4 digit number representing the current minimum alarm level setting. (The default setting for the °C range is -100.0).
6. Use the '⇨' and '⇩' keys to set the required new value (e.g. -148.0).
7. Press the 'SET' key to accept the new value. The display will read 'SU-u'.
8. Press the '⇨' key once to display a flashing 4 digit number representing the current maximum alarm level setting. (The default setting for the °C range is 020.0)
9. Use the '⇨' and '⇩' keys to set the required new value (e.g. 068.0).
10. Press the 'SET' key to accept the new value, followed by the 'P' key to return to the main display.

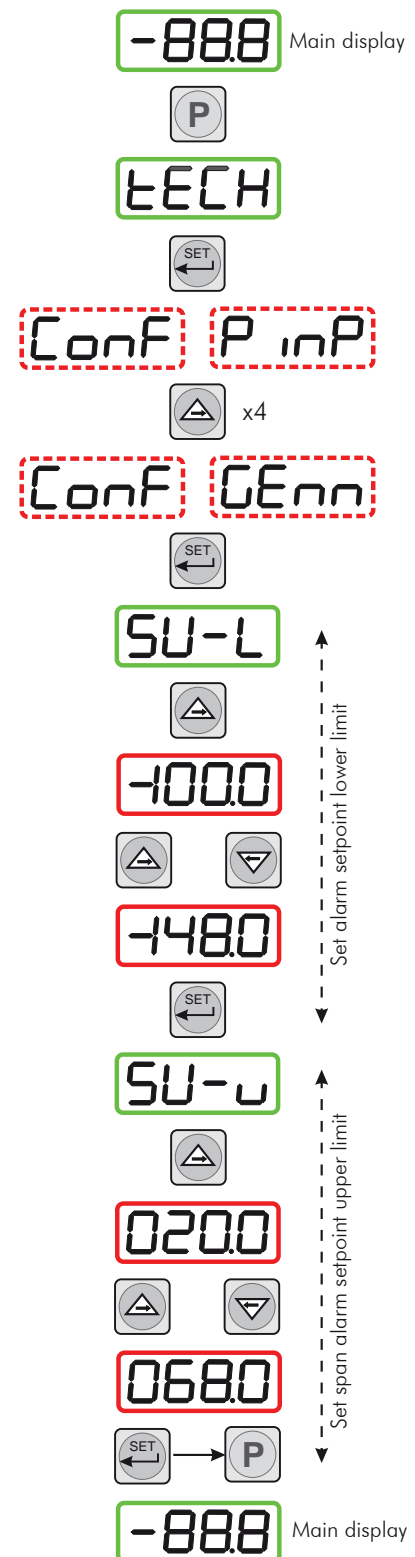

Figure 3.10 Set-up alarm set-point limits

3.7.3 Change Scale Units (to ppm_v)

To change the process indicator to read parts per million by volume (ppm_v) proceed as follows:

Figure 3.11 shows the operational key sequence.

Note: The dew-point transmitter must first be programmed to provide an output proportional to ppm_v by using the Michell application software. Contact Michell Instruments for information (for contact details see Appendix D).

1. Press the 'P' key once, the display will read 'tECH'.
2. Press the 'SET' key four times and the display will read 'dPnt'.
3. Press the '⇒' key, the display will flash the current decimal point position (0001).
4. Press the '⇐' key to set 0000 on the display (no decimal point), and press the 'SET' key twice. 'tPoL' is then displayed.
5. Press the '⇒' key, the display will flash the current minimum span limit (-1000)
6. Use the '⇒' and '⇐' keys to set the required ppm_v minimum reading (0000) and press the 'SET' key. 'tPoH' is then displayed.
7. Press the '⇒' key, the display will flash the current maximum span limit (0200).
8. Use the '⇒' and '⇐' keys to set the required ppm_v maximum reading (3000) and press the 'SET' key twice. 'unit' is then displayed.
9. Press the '⇒' key, the display will flash the current unit (°C).
10. Press the '⇒' key three times to set the display reading to '_' (ppm_v) and press the 'SET' key. 'LoL' is then displayed.
11. Press the '⇒' key, the display will flash the current alarm lower range limit (-1000) (formerly -100.0 with no sign or decimal point showing).
12. Use the '⇒' and '⇐' keys to set the required alarm lower range limit (point where display starts to flash) (0 or different value), and press the 'SET' key. 'uPL' is then displayed.
13. Press the '⇒' key, the display will flash the current alarm upper range limit (0200) (formerly 020.0 with no decimal point showing).
14. Use the '⇒' and '⇐' keys to set the required alarm upper range limit (point where display starts to flash) (3000 or different value), and press the 'SET' key. 'PUoF' is now displayed.
15. Press the 'P' key twice and the main display, now reading ppm_v will show.
NOTE: Neither the °C nor the °F LED indicators on the front panel of the process indicator are now lit.

On completion of the above procedure appropriate alarm levels, relevant to the new ppm_v scale, will need to be set-up (refer to Section 3.6.2).

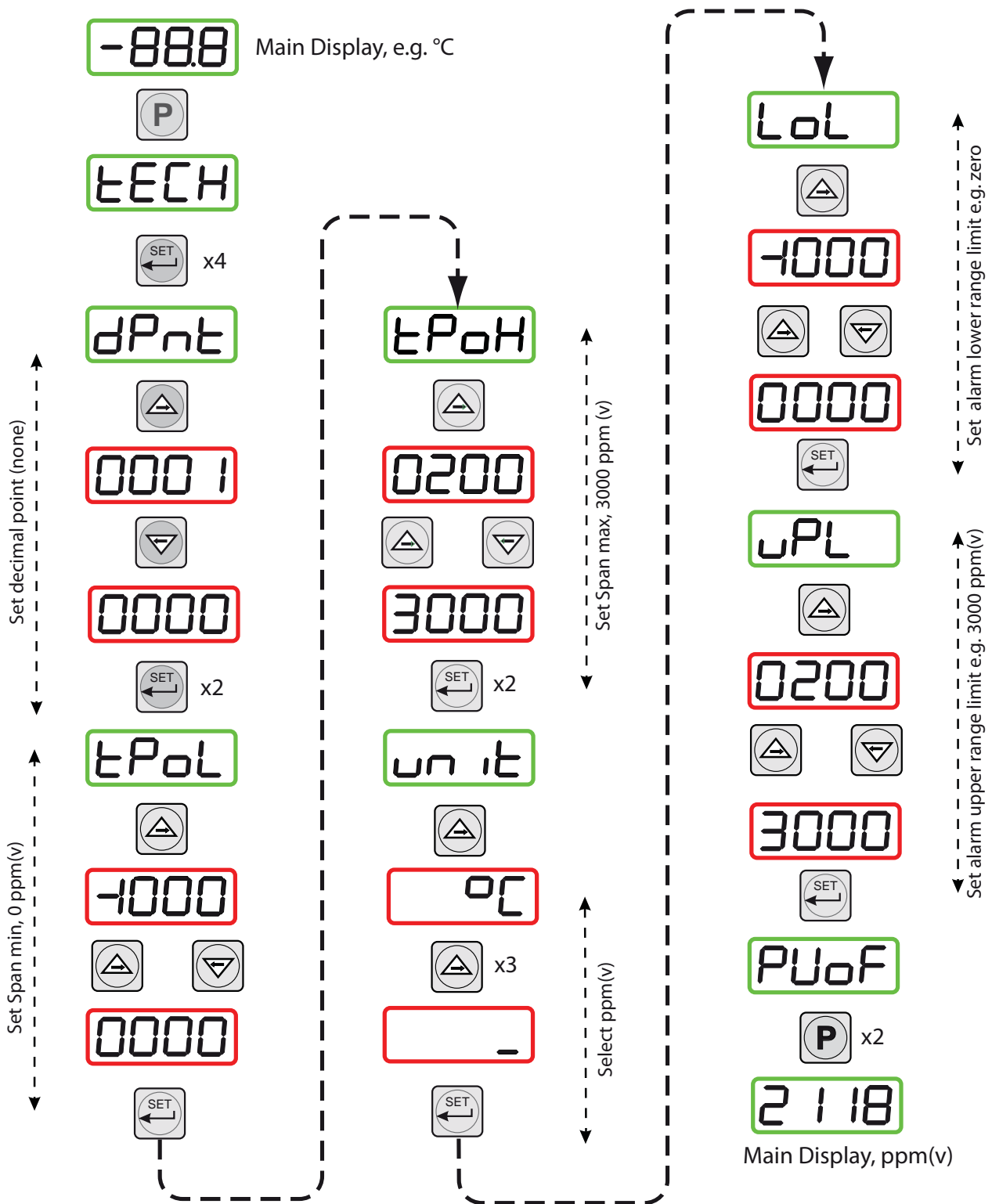

Figure 3.11 Set-up process indicator (to read ppm_v)

3.7.4 Display Limits When Unit Scaled to ppm_v

When unit is scaled to ppm_v the display will read zero when the mA input signal is between 3 and 4 mA.

NOTE: On displays supplied before December 2011 the display will show negative ppm_v values when the sensor input signal is between 3 and 4 mA.

4 SENSOR INSTALLATION

4.1 Transmitter Connections

Connect the transmitter cable to the Process Indicator (1) as shown in *Figure 4.1*.

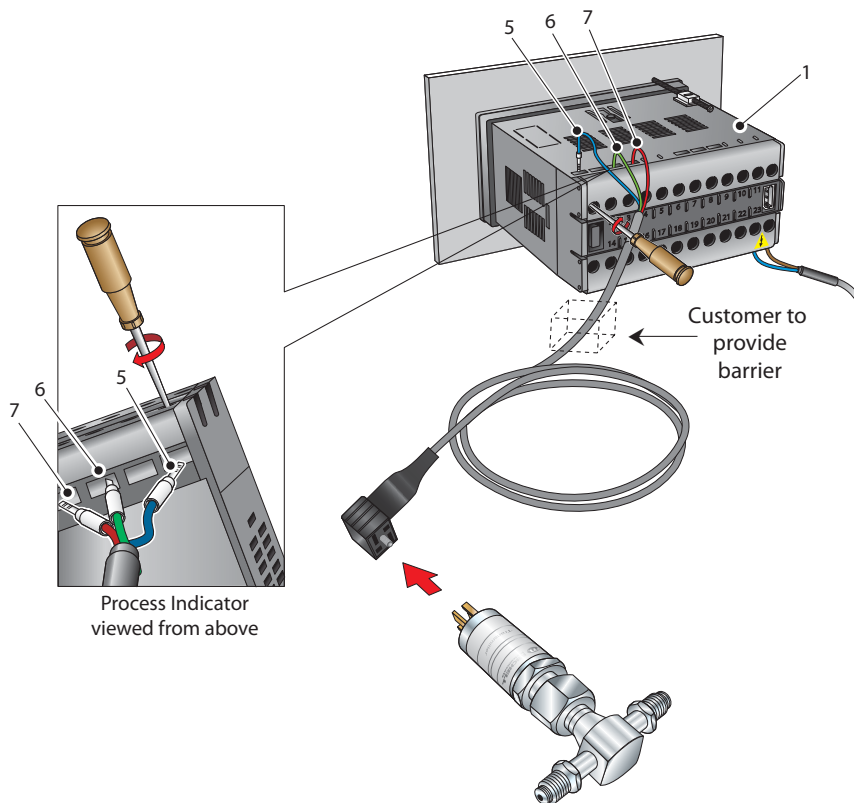

Figure 4.1 Transmitter connections

1. Connect the blue wire (5) of the transmitter cable to terminal 1 on the Process Indicator.
2. Connect the green wire (6) of the transmitter cable to terminal 3 on the Process Indicator.
3. Connect the red wire (7) of the transmitter cable to terminal 4 on the Process Indicator.
4. Check that the transmitter cable wiring has been completed correctly.

4.2 Installing the Sensor

The effective operation of the Pura I.S. Transmitter, in a flowing gas environment, relies on the sensor being installed directly into the gas stream or by having a fully representative gas sample directed over the sensor measurement surface. Where possible avoid installing the sensor in a "dead" or unswept volume.

Michell Instruments recommends the use of Swagelok® retained gasket assemblies, containing silver plated, stainless steel ¼" VCR gaskets, when connecting the Pura I.S. Transmitter into a gas line. The distance between the inlet and outlet gas connection ports is set at a pitch of 120mm.

- Install the sealing gasket onto the VCR connections on either the Pura I.S. Transmitter or the connecting gas lines. Ensure that the Pura I.S. Transmitter is offered into the gas line with reference to the gas flow direction and the inlet port as indicated on the Pura I.S. Transmitter body.
- Tighten the female nut firmly - finger tight.
- While holding the Pura I.S. Transmitter stationary with a spanner/wrench, tighten the gas line nut 1/8 (one eighth) of a turn using a second spanner.



CAUTION: Over-tightening the nuts can cause irrecoverable damage to the seals and seatings.

- Repeat this operation on the remaining gas connection port.

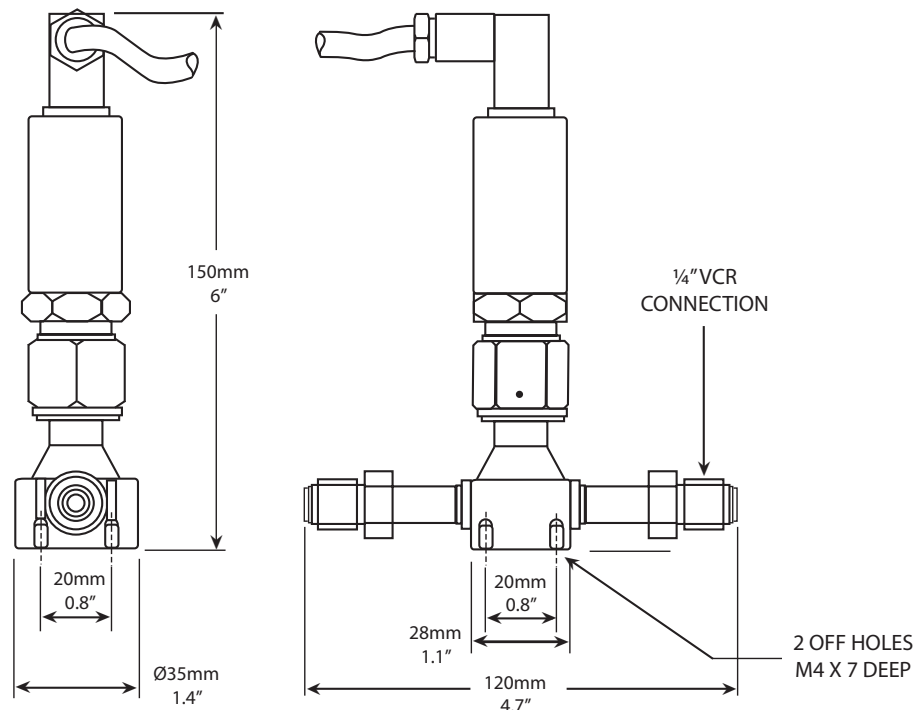

Figure 4.2 Pura I.S. Dew-Point Transmitter

4.3 Transmitter Cable

Cable connection to the Pura I.S. Transmitter is made via the removable connector.



When removing the central screw ensure that the small sealing O-ring is retained on the screw and present during re-installation.

Removing the central screw enables the connector terminal block to be removed from the outer housing by using a small screwdriver to prise it off.

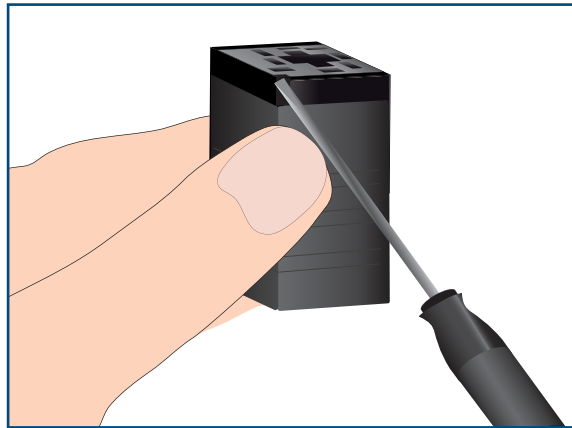

Figure 4.3 *Terminal block Removal*

When reinstalling the connector, and to ensure that full ingress protection is achieved, the securing screw must be tightened to a minimum torque setting of 3.4Nm (2.5 lbs/in) and the sensor cable used must have a minimum diameter of 4.6mm (0.2").

4.4 Preparation of the Sensor Cable



It is essential that, to comply with Hazardous Area Certification of the product, the crimps supplied must be fitted onto any cable installed into the connector.

NOTE: Figures 4.4 to 4.7 shown below, should be followed in detail. The crimps should be applied such that there is no possibility of a conductor strand of a core becoming free.

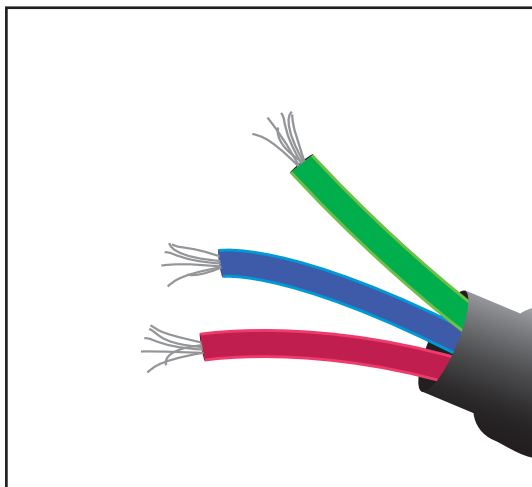

Figure 4.4 Bare wires

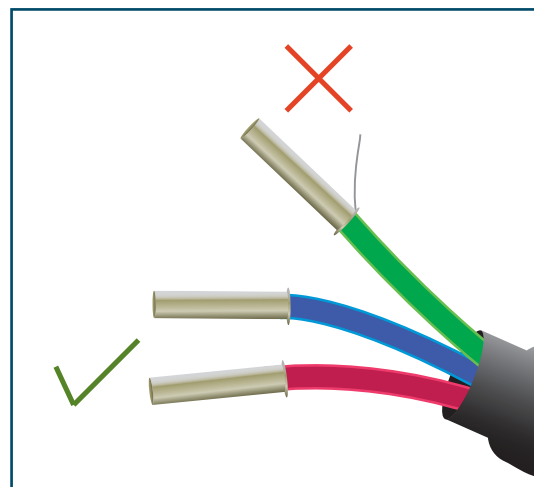

Figure 4.5 Crimped wires

When the crimp is made it should have a minimum of 2 positions of crimping. After the crimp is made it should be trimmed to a length of 5mm (see *Figure 4.6*). When the crimps are installed into the connector terminal block ensure they are fully inserted, as shown in *Figure 4.7*, before tightening the terminal clamping screw.

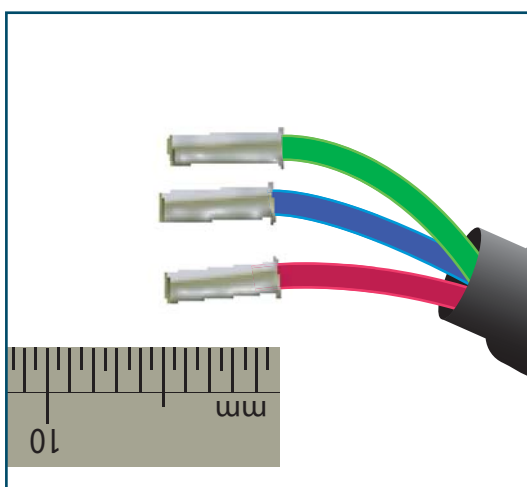

Figure 4.6 Cut to 5mm

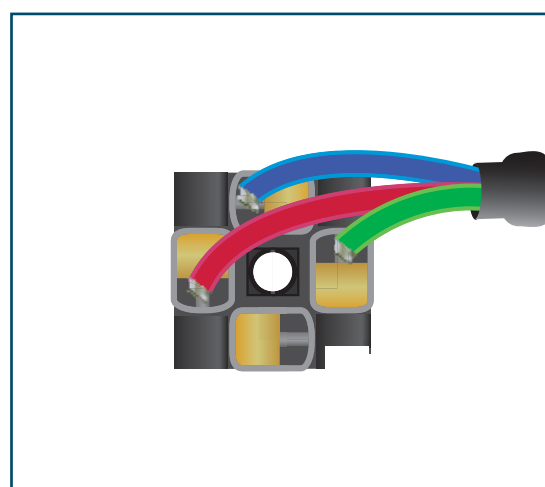

Figure 4.7 Connection to Pura I.S.TX

When all wire connections are made, ensure that there is a minimum clearance distance and a minimum creepage distance in air of 2mm (0.8") between each terminal.

The diagram below shows the identity of the connector terminals:

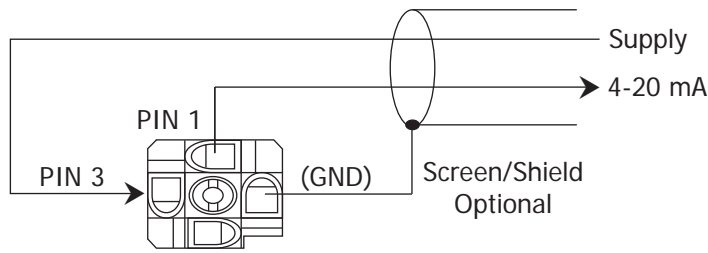

Figure 4.8 Rear of connector terminal block



Always connect the 4-20 mA return signal to a suitable load (see Figure 4.9) before the power is applied. Without this connection the transmitter may be damaged if allowed to operate for prolonged periods.

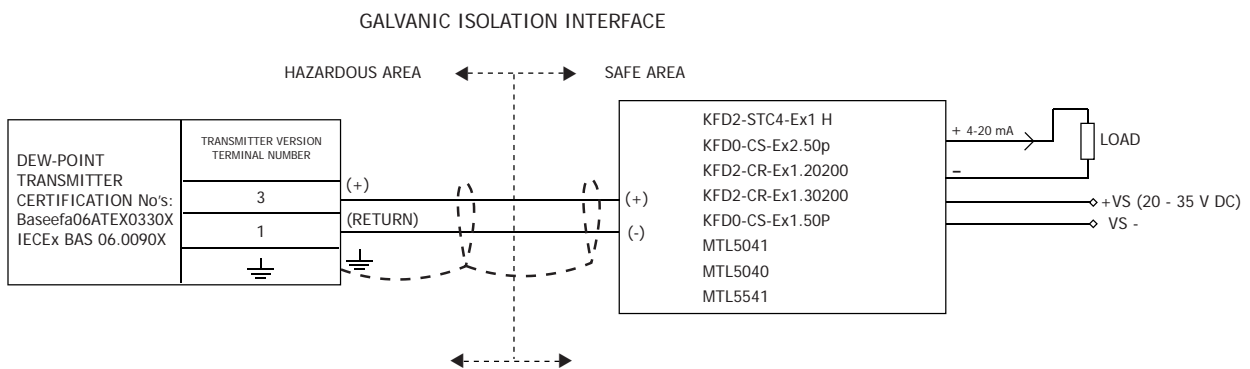
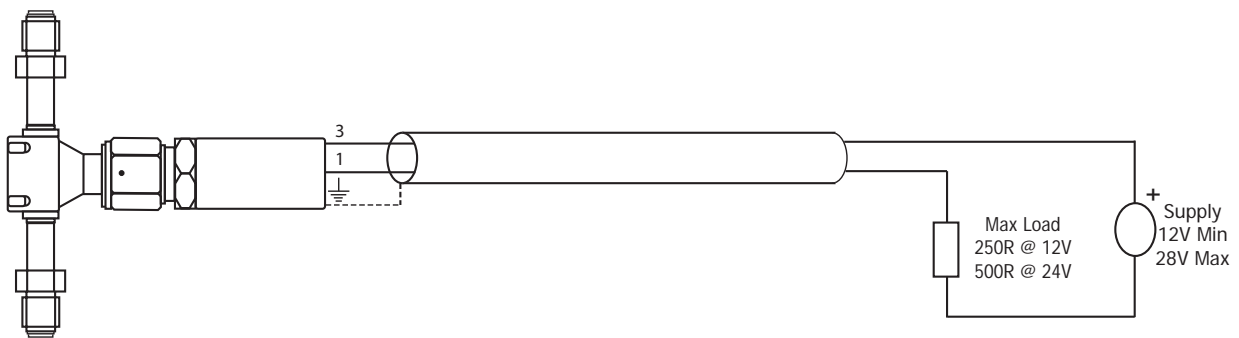

Figure 4.9 Electrical Connections

4.5 Installation in Hazardous Areas

The Transmitter is certified intrinsically safe for use in hazardous areas, by Notified Body Baseefa Ltd. The instrument conforms to the ATEX & IECEx standards with certification code:

 II 1 G Ex ia IIC T4 (-20°C ≤ Ta ≤ +70°C)

The Transmitter is also certified for use in Hazardous Areas by FM Approvals and CSA, with certification code:

IS / I / 1 / ABCD / T4 Ta = +70°C, Entity Ex90385, IP66

Also see Appendix B for more information on certification.

Before using the Transmitter in any hazardous environment, ensure that you are fully familiar with the relevant standards relating to the certification of this instrument; and also with the further information relating to intrinsically safe apparatus to be found in standard EN 60079-14:1997 or equivalent, and up-to-date codes of practice in the country of installation.

The Transmitter must be installed using a specified GALVANICALLY ISOLATED INTERFACE unit as shown in the system drawings in Appendix C



Installation of the Transmitter *MUST* be as per the system drawings in Appendix C in order to comply with the Intrinsic Safety Certification.

5 WHICH GASES TO MEASURE?

The Pura Hygrometer is suitable for measurement of the moisture content of a wide variety of gases. In general, if the gas (in conjunction with water vapor) is not corrosive to ceramics or base metals then it will be suitable for measurement by the Pura Hygrometer.

6 MAINTENANCE

Routine maintenance of the Pura I.S. Transmitter is confined to regular re-calibration. This work can only be done by exposure of the Pura I.S. Transmitter to sample gases of known moisture content. Calibration services traceable to the National Physical Laboratory (UK) and the National Institute of Standards and Technology (USA) are provided by Michell Instruments. In most applications, annual re-calibration ensures that the stated accuracy of the Pura I.S. Transmitter is maintained. Pura I.S. Transmitters are fully interchangeable and interchangeability is not affected by cable length; therefore, this method of maintaining calibration can be used for all Pura I.S. Transmitter installations. For applications where it is not required for continuous operation, re-calibration of the Pura I.S. Transmitter can be achieved by return of the complete instrument to Michell Instruments.



Do not remove the sensor from the block. Doing so will invalidate the product warranty. The complete unit should be returned to Michell Instruments for service / recalibration

7 FAULT CONDITIONS

Message Displayed	Cause	Action
"ErrL"	Sensor failure	Check power supply to transmitter. Check sensor cable for continuity/damage. Rectify/replace cable
	Instrument failure	Return to Michell or your local representative for repair
"Sbr"	Sensor failure or break in sensor connection	Check sensor cable for continuity/damage. Rectify/replace cable
"ErrH"	Gas is wetter than -40°Cdp	Check gas source supply
	Sensor contaminated	Replace/re-calibrate sensor
"outR"	Input out of range	Check gas source supply. Re-calibrate/replace sensor
"rurC"	Reverse input connection	Swap input connections from the sensor to the monitor

Appendix A

Technical Specifications

Appendix A Technical Specifications

Monitor	
Equipment Use	Process indicator – dew-point measurement
Housing & Mounting	48 x 96 x 86mm (1.9 x 3.8 x 3.4") Horizontal, DIN 43700 Plastic housing for panel mounting. Panel cut out is 46 x 92mm (1.8 x 3.6")
Protection	NEMA 12 (IP65 at front, IP20 at rear)
Weight	Approximately 260g (0.5lb)
Environmental Rating	Standard, indoor at an altitude of less than 2000m with non-condensing humidity
Operating / Storage Temperature	0 to +50°C / -40 to +85°C (+32 to +122°F / -40 to +185°F)
Operating / Storage Humidity	90% max (non condensing)
Installation Over Voltage Category	III, distribution level, fixed installation category
Mode of Operation	Continuous
Supply Voltage	100 to 240 V AC (+10%, -15%), 50/60 Hz (Optional 24 V DC)
Alr 1 Relay	Single pole make contact, rating 3 A @ 250 V AC
Alr 2 Relay	Changeover contacts, rating 5 A @ 250 V AC
Analog Output (if installed)	4-20 mA (or 0-20 mA) over range -120 to -40°C (-184 to -40°F)
Process Display	20mm (0.8"), Red, 4 digit LED display
LED Indicators	AL1, AL2, °C, °F
Power Connection	2 wire, length 2m (6.6ft)
Transmitter Cable	Copper braid screened cable; 4 core 7 / 0.2 (0.22mm ²), stranded, tinned copper conductors, PVC, insulated, Melinex taped, Black PVC outer. Max length 800m (2,624 ft)

Transmitter									
Measurement Range (dew point)	-120 to -40°C (-184 to -40°F) dew point								
Accuracy (dew point)	±1°C from -40 up to -60°C ±2°C from -60 up to -100°C ±4°C from -100 up to -120°C (estimated)								
Repeatability	0.5°C (0.9°F) dew point								
Electrical Output/Input									
Output Signal	4-20 mA (2-wire connection, current source) User-configurable over range								
Output	Dew point, moisture content for ppm _v , ppb _v								
Output Range	Dew point: -120 to -40°C (-184 to -40°F)								
Supply Voltage	12-28 V DC								
Load Resistance	Max 250 Ω @ 12 V (500 Ω @ 24 V)								
Current Consumption	23 mA								
Supply Voltage Influence	±0.005% RH/V								
Operating Conditions									
Operating Humidity	0–100% RH								
Operating Temperature	-40 to +60°C (-40 to +140°F)								
Operating Pressure	24 MPa (240 barg / 3480 psig) max								
Flow Rate	1 to 10 NI/min (2.1 to 21.2 scfh) (5 NI/min (10.6 scfh) optimum)								
Mechanical Specification									
Hazardous Area Certificates	ATEX - II 1 G Ex ia IIC T4 (-20°C ≤ Ta ≤ +70°C) FM - IS / I / 1 / ABCD / T4 Ta = +70°C CSA - IS Class 1 Div 1 Groups ABCD T4 IECEX - Ex ia IIC T4 (-20°C ≤ Ta ≤ +70°C)								
Ingress Protection	IP66 in accordance with standard BS EN 60529:1992, and NEMA 4 in protection accordance with standard NEMA 250-2003								
Housing Material	Stainless steel								
Mounting Thread	¼" male VCR connection ½" male VCR connection								
Weight	Premium and OEM versions: 450g (15.87oz) Pura Sensor version: 180g (6.34oz)								
Interchangeability	Fully interchangeable transmitter								
Electrical Connections	Screw terminal								
Fault Conditions (factory programmed)	<table border="1"> <thead> <tr> <th>Condition</th> <th>Output</th> </tr> </thead> <tbody> <tr> <td>Sensor fault</td> <td>23 mA</td> </tr> <tr> <td>Under-range dew point</td> <td>4 mA</td> </tr> <tr> <td>Over-range dew point</td> <td>20 mA</td> </tr> </tbody> </table>	Condition	Output	Sensor fault	23 mA	Under-range dew point	4 mA	Over-range dew point	20 mA
Condition	Output								
Sensor fault	23 mA								
Under-range dew point	4 mA								
Over-range dew point	20 mA								
Approved Galvanic Isolators	KFD2-CR-Ex1.20200 / KFD2-CR-Ex1.30200 KFD0-CS-Ex1.50P / KFD0-CS-Ex2.50P KFD2-STC4-Ex1 H / MTL5041, MTL5040, MTL5541								
Approved Galvanic Isolators	KFD2-CR-Ex1.20200 / KFD2-CR-Ex1.30200 KFD0-CS-Ex1.50P / KFD0-CS-Ex2.50P KFD2-STC4-Ex1 H / MTL5041, MTL5040, MTL5541								

Appendix B

Hazardous Area Certification

Appendix B Hazardous Area Certification

NOTE: The PURA I.S. product incorporates the ATEX/IECEX/CSA/FM approved Easidew I.S. product and it is the Hazardous Area Certification for the Easidew I.S. that provides the necessary approvals for the PURA I.S.

The Transmitter is certified compliant to the ATEX Directive (94/9/EC), and IECEx for safe use within a hazardous area and has been assessed so by Baseefa Ltd (Notified Body 1180).

This product uses the Easidew TX I.S. PCB assembly and therefore conforms to the Standards EN 60079-0:2004, EN60079-11:2007, IEC60079-0:2004, IEC60079-11:1999 and is attributed with a product certification code:

 II 1 G Ex ia IIC T4 (-20°C ≤ Ta ≤ +70°C)

ATEX Certificate Number : Baseefa06ATEX0330X
ATEX System Certificate Number: Baseefa07Y0027
IEC Certificate Number: IECEx BAS 06.0090X

It is also certified for use in Hazardous Areas by FM Approvals and CSA, with certification code:

IS / I / 1 / ABCD / T4 Ta = +70°C, Entity Ex90385, IP66

FM Certificate Number: 3030238
CSA Certificate Number: 2013218

These certificates can be viewed or downloaded from our website (under Easidew TX I.S.) at: <http://www.michell.com/accreditations>

B1 Terminal Parameters

Ui	= 28V
Ii	= 93mA
Pi	= 651mW
Ci	= 37nF
Li	= 0

B2 Special Conditions of Use

Wiring to the free socket must be made via crimped connectors such that all strands of the wires are retained securely by the crimp.

The plastic plug & socket provide potential for electrostatic discharge. Do not rub with a dry cloth and do not clean with solvents.

The Transmitter does not withstand the 500 V AC insulation test to frame. This must be taken into account when installing the equipment.

Appendix C

System Drawings

Appendix C System Drawings

NOTE: The Pura I.S. sensor uses the Easidew I.S. PCB assembly and therefore this certification is valid for this instrument.

C1 Baseefa Approved System Drawing

TABLE A

Type	Certificate Number	Interface	Connection to Easidew I.S.
Isolated Repeater	BAS98ATEX7943	KFD0-CS-Ex1.50P	Pin 1 (+) Pin 2 (-)
Dual Isolated Repeater	BAS98ATEX7943	KFD0-CS-Ex2.50P	Channel 1 - Pin 1 (+) Channel 1 - Pin 2 (-) Channel 2 - Pin 4 (+) Channel 2 - Pin 5 (-)
Transmitter Supply Isolator	BAS00ATEX7164	KFD2-CR-Ex1.20200	Pin 1 (+) Pin 3 (-)
Transmitter Supply Isolator	BAS00ATEX7164	KFD2-CR-Ex1.30200	Pin 1 (+) Pin 3 (-)
Smart Transmitter Power Supply	BAS99ATEX7060	KFD2-STC4-Ex1.H	Pin 1 (+) Pin 3 (-)
Repeater Power Supply	BAS01ATEX7155	MTL5041	Pin 2 (+) Pin 1 (-)
Dual Loop Isolator	BAS98ATEX2227	MTL5040	Pin 2 (+) Pin 1 (-) Pin 5 (+) Pin 4 (-)
Repeater Power Supply	BaseefaATEX0213	MTL5541	Pin 2 (+) Pin 1 (-)

TRANSMITTER VERSION	TERMINAL NUMBER	EASIDEW PRO I.S.
3	3	(+)
2	1	(RETURN)
4	4	(-)
3	3	(-)

SYSTEM LABEL
MICHELL Instruments
 EASIDEW I.S. DEWPOINT TRANSMITTER
 SYSTEM CERTIFICATE No's: Baseefa07Y0027
 Exia IIC T4 (-20C TO +60C)

DRAWING TITLE BLOCK:
 TITLE: EASIDEW I.S. and EASIDEW PRO I.S. DEWPOINT TRANSMITTER SYSTEM DRAWING
 DRAWING UNITS: mm
 SCALE: NTS
 DRAWING No: 11165
 ISSUE No: 03
 CERT ISS: 27/05/09
 ISSUE MOD. No.: 01
 DATE: 26/01/07
 DRAWING NUMBER: Ex90352
 SHEET 1 OF 1

THE CAPACITANCE AND EITHER THE INDUCTANCE OR THE INDUCTANCE TO RESISTANCE RATIO (L/R) OF THE CABLE MUST NOT EXCEED THE FOLLOWING VALUES:

GROUP	CAPACITANCE (µF)	OR	INDUCTANCE (mH)	OR	L/R RATIO (µH/ohm)
IIC	SEE NOTE 1 * 40 nF		4.2mH		54 µH/Ω
IIB	613 nF		12.6mH		217 µH/Ω
I/A	2.11 µF		33mH		435 µH/Ω

THE ISOLATION OF THE SIGNAL WIRES WITH THE EASIDEW DISCONNECTED, MUST BE ABLE TO WITHSTAND A 500V AC INSULATION TEST.
AT INSTALLATION OF SYSTEM PERFORM A RISK ASSESSMENT IN ACCORDANCE WITH EN60079-25:2004 cl.10 AND INSTALL LIGHTENING PROTECTION AS NECESSARY.
THE SYSTEM MUST BE MARKED WITH A DURABLE LABEL. THE LABEL SHOULD APPEAR ON OR ADJACENT TO THE PRINCIPAL ITEM OF ELECTRICAL APPARATUS IN THE SYSTEM OR AT THE INTERFACE BETWEEN THE INTRINSICALLY SAFE AND NON-INTRINSICALLY SAFE CIRCUITS. THIS MARKING SHALL INCLUDE THE FOLLOWING INFORMATION:
 Baseefa 07Y0027 AND THE WORD SYST OR SYSTEM.

NOTE 1. 46nF MAXIMUM CABLE CAPACITANCE IS ACCEPTABLE IN IIC INSTALLATIONS FOR THE INTRINSIC SAFETY ISOLATORS SHOWN IN THE LIST BELOW.
 FOR ISOLATORS NOT LISTED BELOW, BUT APPEARING IN TABLE A, ONLY 40nF MAXIMUM CABLE CAPACITANCE IS ACCEPTABLE.
 KFD0-CS-Ex1.50P
 KFD0-CS-Ex2.50P
 KFD0-CR-Ex1.20200
 KFD0-CR-Ex1.30200
 MTL5041
 MTL5040
 MTL5541

C2 FM Approved System Drawing

THE CAPACITANCE AND EITHER THE INDUCTANCE OR THE INDUCTANCE TO RESISTANCE RATIO (L/R) OF THE CABLE MUST NOT EXCEED THE FOLLOWING VALUES:

GROUP	CAPACITANCE (µF)	INDUCTANCE (mH) OR	L/R RATIO (µH/ohm)
D	2.11 µF	33mH	435 µH/Ω
C	613 nF	12.6 mH	217 µH/Ω
AB	46 nF	4.2mH	54µH/Ω

THE ISOLATION OF THE SIGNAL WIRES WITH THE EASIDEW DISCONNECTED, MUST BE ABLE TO WITHSTAND A 500V AC INSULATION TEST.

THE INSTALLATION MUST COMPLY WITH THE INSTALLATION PRACTICES OF THE COUNTRY OF USE, i.e. ANSI/ISA12.6(INSTALLATION OF INTRINSICALLY SAFE SYSTEMS FOR HAZARDOUS (CLASSIFIED) LOCATIONS) AND THE NATIONAL ELECTRICAL CODE (ANSI/NFPA 70).

THE CAPACITANCE AND THE INDUCTANCE OF THE HAZARDOUS AREA CABLES MUST NOT EXCEED THE VALUES GIVEN IN TABLE 1.

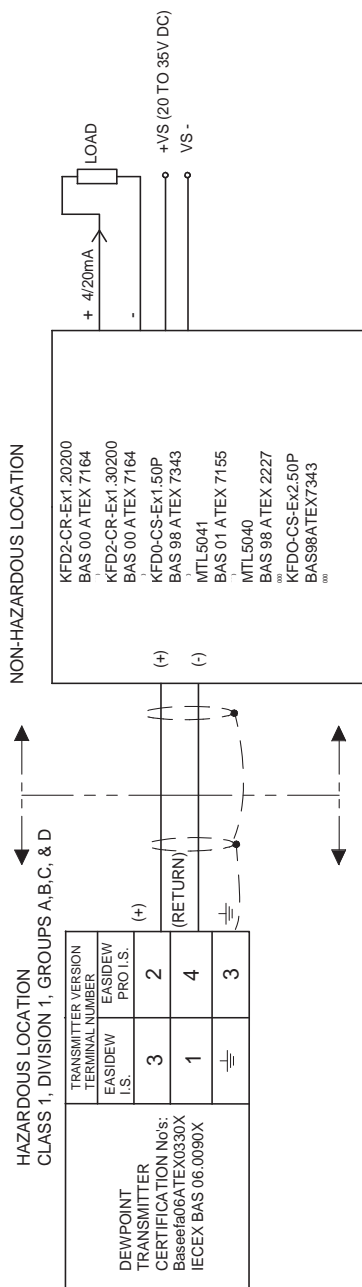

3rd ANGLE PROJECTION 	TOLERANCES: UNLESS OTHERWISE STATED 0 DEC. PLACE: ±0.5 HOLE Ø: -0.0 DIMENSIONS: 1 DEC. PLACE: ±0.2 ANGLES: ±0.5° 2 DEC. PLACE: ±0.1	DRAWING UNITS mm	SCALE NTS	05 11081 06/04/11 IMA 04 CERT ISS 24/03/09 IMA 03 CERT ISS 21/01/09 IMA 02 CERT ISS 23/12/08 IMA 01 CERT ISS 16/07/07 IMA ISSUE MOD. No. DATE SIGN
MATERIAL FINISH				DRAWING NUMBER Ex90385
TITLE EASIDEW I.S. DEWPOINT TRANSMITTER FM SYSTEM DRAWING				SHEET 1 OF 1 A3
USED ON MICHELL INSTRUMENTS LTD. CAMBRIDGE ©				
THIS DOCUMENT IS THE PROPERTY OF MICHELL INSTRUMENTS LTD. AND MUST NOT BE COPIED NOR DISCLOSED TO A THIRD PARTY WITHOUT THE CONSENT OF MICHELL INSTRUMENTS.			APPROVED DATE	
DRAWN MSB DATE 10/03/06	CHECKED DATE			
MICHELL INSTRUMENTS LTD. 01/11/05 D0F03				



C3 CSA Approved System Drawing

THE CAPACITANCE AND EITHER THE INDUCTANCE OR THE INDUCTANCE TO RESISTANCE RATIO (L/R) OF THE CABLE MUST NOT EXCEED THE FOLLOWING VALUES:

GROUP	CAPACITANCE (µF)	INDUCTANCE (mH) OR	L/R RATIO (µH/ohm)
IIC	46 nF	4.2mH	54 µH/Ω
IIB	613 nF	12.6 mH	217 µH/Ω
IIA	2.1 µF	33mH	435 µH/Ω

THE ISOLATION OF THE SIGNAL WIRES WITH THE EASIDEW DISCONNECTED, MUST BE ABLE TO WITHSTAND A 500V AC INSULATION TEST.

THE INSTALLATION MUST COMPLY WITH THE INSTALLATION PRACTICES OF THE COUNTRY OF USE, i.e. ANSI/ISA RP12.6 (INSTALLATION OF INTRINSICALLY SAFE SYSTEMS FOR HAZARDOUS [CLASSIFIED] LOCATIONS) AND THE NATIONAL ELECTRICAL CODE (ANSI/NFPA 70).

THE CAPACITANCE AND THE INDUCTANCE OF THE HAZARDOUS AREA CABLES MUST NOT EXCEED THE VALUES GIVEN IN TABLE 1

- Intrinsically safe(arity), Class 1, Div1, Group A,B,C,D Hazardous Location Installations
- 1) Control room equipment may not use or generate over 250Vrms
 - 2) Wire all circuits for power supply per CEC Part 1.
 - 3) Use only entity approved safety barrier or other associated equipment that satisfy the following conditions:

$$V_{oc} \leq V_{max}, I_{sc} \leq I_{max}, C_{cable} \leq C_i + C_{cable}, L_s \leq L_i + L_{cable}$$

Transmitter entity parameters are as follows:

$$V_{max} < 2.8Vdc$$

$$I_{max} < 93mA$$

$$C_i = 37nF$$

$$L_i = 0uH$$

- 4) WARNING: SUBSTITUTION OF COMPONENTS MAY IMPARE INTRINSIC SAFETY.
- 5) Ex (a) is defined as Intrinsically Safe.

Type	Certificate Number	Interface	Connection to Easidew I.S.
Isolated Repeater	BAS99ATEX7343 UL Canada E106378CUL	KFD0-CS-Ex1.50P	Pin 1 (+) Pin 2 (-)
Dual Isolated Repeater	BAS00ATEX7343 UL Canada E106378CUL	KFD0-CS-Ex2.50P	Channel 1 - Pin 1 (+) Channel 1 - Pin 2 (-) Channel 2 - Pin 4 (+) Channel 2 - Pin 5 (-)
Transmitter Supply Isolator	BAS00ATEX7164 UL Canada E106378CUL	KFD2-CR-Ex1.20200	Pin 1 (+) Pin 3 (-)
Transmitter Supply Isolator	BAS00ATEX7164 UL Canada E106378CUL	KFD2-CR-Ex1.30200	Pin 1 (+) Pin 3 (-)
Smart Transmitter Power Supply	BAS99ATEX7060 UL Canada E106378CUL	KFD2-STC4-Ex1 H	Pin 1 (+) Pin 3 (-)

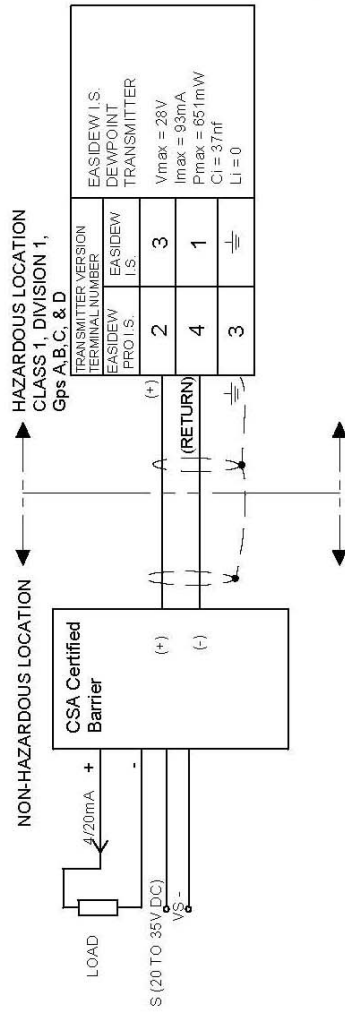

<p>3rd ANGLE PROJECTION</p> <p>TOLERANCES: UNLESS OTHERWISE STATED 0 DEC. PLACE: ±0.5 HOLE Ø: -0.0 DIMENSIONS: 1 DEC. PLACE: ±0.2 ANGLES: ±0.5° 2 DEC. PLACE: ±0.1</p>	<p>DRAWING UNITS: mm</p> <p>SCALE: NTS</p>	<p>CERT ISS: 15/03/09 IMA</p> <p>CERT ISS: 25/03/09 IMA</p> <p>CERT ISS: 16/06/08 IMA</p> <p>CERT ISS: 13/05/08 IMA</p> <p>CERT ISS: 16/07/07 IMA</p> <p>ISSUE MOD. No. DATE</p>	<p>DRAWING NUMBER: EX90385CSA</p>
<p>TITLE: EASIDEW I.S. & EASIDEW PRO I.S. DEWPOINT TRANSMITTER SYSTEM DRAWIN. CSA</p>		<p>USED ON: MICHELL INSTRUMENTS LTD. CAMBRIDGE ©</p>	

THIS DOCUMENT IS THE PROPERTY OF MICHELL INSTRUMENTS LTD. AND MUST NOT BE COPIED NOR DISCLOSED TO A THIRD PARTY WITHOUT THE CONSENT OF MICHELL INSTRUMENTS.

DRAWN: MSB	CHECKED: []	APPROVED: []	DATE: []
DATE: 10/03/06	DATE: []	DATE: []	DATE: []

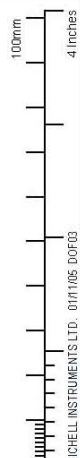

Appendix D

List of Worldwide Michell Instruments' Offices

Appendix D List of Worldwide Michell Instruments' Offices

<p>Asia Michell Asia PO Box 3149 Joondalup WA 6027 Australia Tel: +61 893 046587 E-mail: au.info@michell.com Web: www.michell.com/au</p>	<p>Benelux Michell Instruments Benelux BV Krombraak 11 4906 CR Oosterhout The Netherlands Tel: +31 162 680 471 Fax: +31 162 437 566 E-mail: nl.info@michell.com Web: www.michell.com/nl</p>
<p>China Michell Instruments (Shanghai) Ltd Room 1007, Qilai Building 889 Yishan Road Shanghai, 200233 P R China Tel: +86 21 5401 2255 Fax: +86 21 5401 2085 E-mail: cn.info@michell.com Web: www.michell.com/cn</p>	<p>France Michell Instruments SAS 2-4, rue Jean Desparmet 69008 Lyon France Tel: +33 437 53 88 20 Fax: +33 437 53 88 21 E-mail: fr.info@michell.com Web: www.michell.com/fr</p>
<p>Germany, Austria, Switzerland Michell Instruments GmbH Industriestrasse 27 D-61381 Friedrichsdorf Germany Tel: +49 6172 591700 Fax: +49 6172 591799 E-mail: de.info@michell.com Web: www.michell.com/de</p>	<p>Italy Michell Italia Srl Via Capecelatro, 10 20148 Milano Italy Tel: +39 02 4047194 Fax: + 39 02 40010565 E-mail: it.info@michell.com Web: www.michell.com/it</p>
<p>Japan Michell Japan KK Musashino Center Building 1-19-18 Nakacho, Musashino Tokyo 180-0006 Japan Tel: +81 422 502600 Fax: +81 422 521700 E-mail: info@michell-japan.co.jp Web: www.michell-japan.co.jp</p>	<p>Middle East Michell Instruments Middle East P-06, #097 Sharjah Airport Int'l free zone Sharjah, United Arab Emirates Tel: +971 6 5575028 Fax: +971 6 5575029 E-mail: me.info@michell.com</p>
<p>North America Michell Instruments Inc 319 Newburyport Turnpike, Suite 207 Rowley, MA 01969 USA Tel: +01 978 484 0005 Fax: +01 978 843 7669 E-mail: us.info@michell.com Web: www.michell.com/us</p>	<p>United Kingdom Michell Instruments Ltd 48 Lancaster Way Business Park Ely, CB6 3NW Cambridgeshire England Tel: +44 1353 658000 Fax: +44 1353 658199 E-mail: info@michell.com Web: www.michell.com/uk</p>

NOTES:



<http://www.michell.com>