

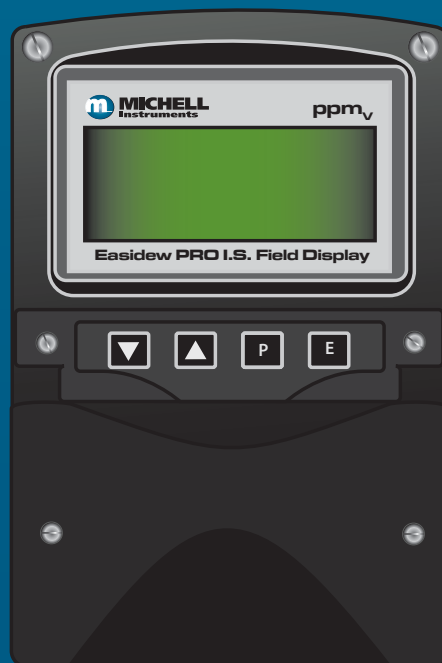

# Intrinsically Safe Field Display

## User's Manual



97321 Issue 2.3  
May 2016

Please fill out the form(s) below for each instrument that has been purchased.

Use this information when contacting Michell Instruments for service purposes.

Instrument	
Code	
Serial Number	
Invoice Date	
Location of Instrument	
Tag No	

Instrument	
Code	
Serial Number	
Invoice Date	
Location of Instrument	
Tag No	

Instrument	
Code	
Serial Number	
Invoice Date	
Location of Instrument	
Tag No	



## I.S. Field Display

For Michell Instruments' contact information please go to  
[www.michell.com](http://www.michell.com)

© 2016 Michell Instruments

This document is the property of Michell Instruments Ltd. and may not be copied or otherwise reproduced, communicated in any way to third parties, nor stored in any Data Processing System without the express written authorization of Michell Instruments Ltd.

---

## Contents

Safety .....	vi
Toxic Materials .....	vi
Repair and Maintenance .....	vi
Safety Conformity .....	vi
Abbreviations .....	vi
Warnings .....	vi
1 INTRODUCTION .....	1
1.1 Operation .....	1
1.1.1 Controls .....	2
2 INSTALLATION .....	3
2.1 4-20 mA Input .....	3
2.2 System Design for Gas Hazardous Areas .....	4
2.2.1 Transmitter Loops .....	4
2.2.2 Remote Indication .....	5
2.3 Location .....	6
2.4 Installation Procedure .....	6
2.5 EMC .....	7
3 OPERATION .....	8
3.1 Configuration And Calibration .....	8
3.1.1 Summary of Configuration Functions .....	9
3.1.2 Indicator Function: 'FunC' .....	11
3.1.2.1 'Std' Linear (Default) .....	12
3.1.3 Resolution: 'rESn' .....	12
3.1.4 Position of the Decimal Point: 'dP' .....	12
3.1.5 Re-Range Display or Calibrate Using an External Current Source: 'CAL' .....	13
3.1.6 Re-Range Display or Calibrate Using Internal Reference: 'Set' .....	14
3.1.7 Function of the P Push-Button: 'C -- P' .....	14
3.1.8 Tare Function: 'tArE' .....	15
3.1.9 Security Code: 'Code' .....	15
3.1.10 Reset to Factory Defaults: 'rSet' .....	15
3.1.11 Under and Over-Range .....	16
3.2 External Keypad (Optional) .....	16
3.3 Alarms (Optional) .....	17
3.3.1 Solid State Output .....	18
3.3.2 Intrinsic Safety .....	18
3.3.3 Configuration and Adjustment .....	19
3.3.4 Alarm Enable: 'EnbL' .....	20
3.3.5 Setpoint Adjustment: 'SP1' and 'SP2' .....	20
3.3.6 Alarm Function: 'Hi.Lo' .....	21
3.3.7 Alarm Output Status: 'no.nC' .....	21
3.3.8 Hysteresis: 'HStr' .....	21
3.3.9 Alarm Delay: 'dELA' .....	22
3.3.10 Alarm Silence Time: 'SiL' .....	22
3.3.11 Flash Display when Alarm Occurs: 'FLSH' .....	23
3.3.12 Access Setpoint in Display Mode: 'ACSP' .....	23
3.3.13 Adjusting Alarm Setpoints from the Display Mode .....	24
3.4 Display Backlight (Optional) .....	25
3.4.1 Loop Powering the Backlight .....	25
3.4.2 Separately Powering the Backlight .....	26
3.5 Pipe-Mounting Kits .....	27

4	MAINTENANCE .....	28
4.1	Fault Finding During Commissioning .....	28
4.2	Fault Finding After Commissioning.....	28
4.3	Servicing .....	28
4.4	Routine Maintenance.....	28

## Figures

Figure 1	Indicator Block Diagram.....	2
Figure 2	Loop-Powered by a Galvanic Isolator (Easidew PRO I.S.).....	4
Figure 3	Loop-Powered by a Galvanic Isolator (Easidew TX I.S.) .....	4
Figure 4	Alternative Circuits for Remote Indication in a Hazardous Area .....	5
Figure 5	Installation Procedure .....	6
Figure 6	Dimensions & Terminal Connections.....	7
Figure 7	Configuration Menu .....	10
Figure 8	Alarm Outputs.....	17
Figure 9	Equivalent Circuit of Each Alarm Output .....	18
Figure 10	Typical Alarm Application .....	18
Figure 11	Alarm Configuration Functions in Configuration Menu.....	19
Figure 12	Terminals for Optional Backlight .....	25
Figure 13	Loop-Powered Backlight.....	25
Figure 14	Separately Powered Backlight.....	26
Figure 15	Pipe-Mounting Kit.....	27

## Appendices

Appendix A	Hazardous Area Certification .....	30
A.1	ATEX Certification .....	30
A.2	Product Standards .....	30
A.3	Product Certification .....	30
A.4	Global Certificates/Approvals .....	31
A.5	Input Terminal Parameters .....	31
A.6	Special Conditions.....	31
A.7	Non- Incendive.....	31
A.8	Maintenance and Installation .....	31
Appendix B	EC Declaration of Conformity.....	43
Appendix C	Quality, Recycling & Warranty Information.....	45
C.1	Pressure Equipment Directive (PED) 97/23/EC .....	45
C.2	Recycling Policy .....	45
C.3	WEEE Compliance.....	45
C.4	RoHS2 Compliance .....	46
C.5	Warranty.....	46
C.6	REACH Compliance .....	47
C.7	Calibration Facilities .....	47
C.8	Return Policy .....	48
C.9	Manufacturing Quality .....	48
Appendix D	Return Document & Decontamination Declaration.....	50

## Safety

The manufacturer has designed this equipment to be safe when operated using the procedures detailed in this manual. The user must not use this equipment for any other purpose than that stated. Do not apply values greater than the maximum value stated.

This manual contains operating and safety instructions, which must be followed to ensure the safe operation and to maintain the equipment in a safe condition. The safety instructions are either warnings or cautions issued to protect the user and the equipment from injury or damage. Use qualified personnel and good engineering practice for all procedures in this manual.

## Toxic Materials

The use of hazardous materials in the construction of this instrument has been minimized. During normal operation it is not possible for the user to come into contact with any hazardous substance which might be employed in the construction of the instrument. Care should, however, be exercised during maintenance and the disposal of certain parts.

## Repair and Maintenance

The instrument must be maintained either by the manufacturer or an accredited service agent. Refer to [www.michell.com](http://www.michell.com) for details of Michell Instruments' worldwide offices contact information.

## Safety Conformity

This product meets the essential protection requirements of the relevant EU directives. Further details of applied standards may be found in the product specification.

## Abbreviations

The following abbreviations are used in this manual:

AC	alternating current
°C	degrees Celsius
dp	dew point
mA	milliampere
max	maximum
V	Volts

## Warnings

The following general warnings listed below are applicable to this instrument. They are repeated in the text in the appropriate locations.



**Where this hazard warning symbol appears in the following sections, it is used to indicate areas where potentially hazardous operations need to be carried out.**

## 1 INTRODUCTION

This field mounting, intrinsically safe digital indicator displays the current flowing in a 4-20 mA loop in engineering units. It is loop-powered but only introduces a 1.2 V drop, which allows it to be installed into almost any 4-20 mA current loop. No additional power supply or battery is required.

The size of the display is 4 digits, 34mm high.

This instruction manual supplements the instruction sheet supplied with the instrument.

The main application of this instrument is to display a measured variable or control signal in a hazardous process area. The zero and span of the display are independently adjustable so that the I.S. Field Display can be calibrated to display any variable represented by the 4-20 mA current, e.g. dew point, ppm<sub>v</sub> or ppm<sub>w</sub>. **NOTE: The instrument will only display the unit selected at order - dp, ppm<sub>v</sub> or ppm<sub>w</sub>.**

The I.S. Field Display been certified intrinsically safe for use in gas and dust hazardous areas by Notified Body Intertek Testing and Certification Ltd and complies with the European ATEX Directive 94/9/EC and also in accordance with the IECEx Scheme. **Dust certification is an option which must be requested when the instrument is ordered.**

The EC-Type Examination certificate specifies that, under fault conditions, the output voltage, current and power at the 4-20 mA input terminals will not exceed those specified for simple apparatus in Clause 5.7 of EN 60079-11, which simplifies installation and documentation.

For installations in the USA and Canada the I.S. Field Display complies with FM and cFM certification. **FM and cFM certification is an option which must be requested when the instrument is ordered.**

### 1.1 Operation

*Figure 1* shows a simplified block diagram of the I.S. Field Display. The 4-20 mA input current flows through resistor R1 and forward biased diode D1. The voltage developed across D1, which is relatively constant, is multiplied by a switch mode power supply and used to power the instrument. The voltage developed across R1, which is proportional to the 4-20 mA input current, provides the input signal for the analog to digital converter.

Each time a 4-20 mA current is applied to the instrument, initialization is performed during which all segments of the display are activated. After five seconds the instrument displays the input current using the calibration information stored in the instrument memory. If the loop current is too low to power the instrument it will display the error message **LPLo**.

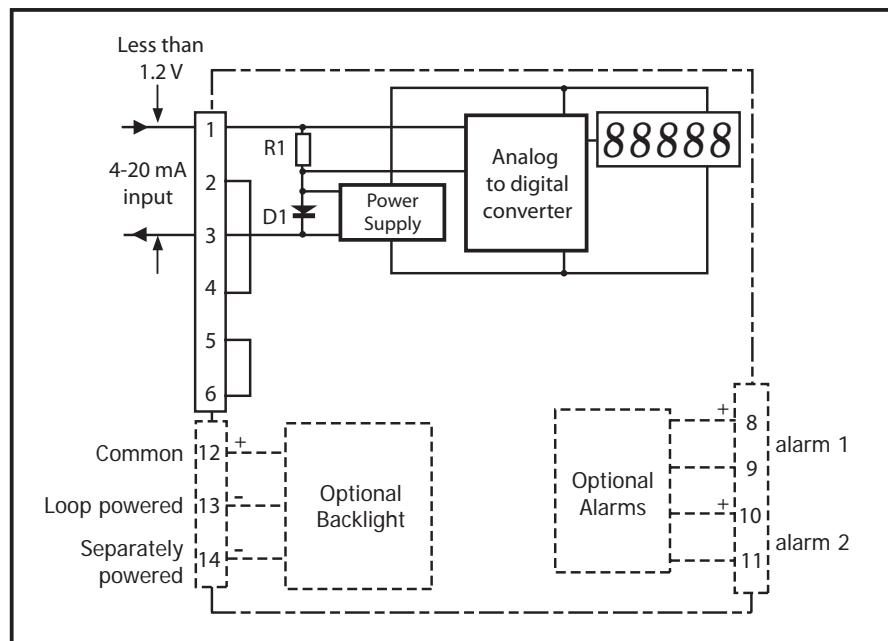
Figure 1 *Indicator Block Diagram*

### 1.1.1 Controls

The I.S. Field Display is controlled and calibrated via four push-button switches located behind the instrument control cover, or as an option on the control cover. In the display mode, i.e. when the instrument is displaying a process variable, these buttons have the following functions:

- P** When this button is pushed the instrument will display the input current in mA or as a percentage of the instrument span, depending upon how the I.S. Field Display has been conditioned. When the button is released the normal display in engineering units will return. The function of this push-button is modified when optional alarms are fitted to the I.S. Field Display.
- ▼** When this button is pushed the instrument will display the numerical value the I.S. Field Display has been calibrated to display with a 4 mA input. When released the normal display in engineering units will return.
- ▲** When this button is pushed the instrument will display the numerical value the I.S. Field Display has been calibrated to display with a 20 mA input. When released the normal display in engineering units will return.
- E** No function in the display mode unless the tare function is being used.
- P + ▼** Indicator displays firmware number followed by version.
- P + ▲** Provides direct access to the alarm setpoints when optional alarms are fitted to the I.S. Field Display and when the **ACSP** access setpoints in display mode function has been enabled.
- P + E** Provides access to the Configuration Menu via optional security code.



## 2 INSTALLATION

### 2.1 4-20 mA Input

The input safety parameters for the two 4-20 mA input terminals 1 & 3 are:

$$\begin{aligned}U_i &= 30 \text{ V DC} \\I_i &= 200 \text{ mA} \\P_i &= 0.84 \text{ W}\end{aligned}$$

The maximum equivalent capacitance and inductance between the two 4-20 mA input terminals 1 & 3 is:

$$\begin{aligned}C_i &= 13\text{nF} \\L_i &= 16\mu\text{H}\end{aligned}$$

The maximum permitted loop cable parameters can be calculated by adding these figures to  $C_i$  and  $L_i$  of other instruments in the loop and subtracting the totals from the maximum cable capacitance  $C_o$  and cable inductance  $L_o$  permitted for the Zener barrier or galvanic isolator powering the loop.

Although the I.S. Field Display does not itself comply with the requirements for simple apparatus, the EC-Type Examination Certificate states that for intrinsic safety considerations, under fault conditions, the output voltage, current and power at terminals 1 & 3 will not exceed those specified by clause 5.7 of EN 60079-11 for simple apparatus. This simplifies the application and documentation of intrinsically safe loops containing the I.S. Field Display.

2.2 System Design for Gas Hazardous Areas

2.2.1 Transmitter Loops

The I.S. Field Display may be connected in series with almost any intrinsically safe 4-20 mA current loop and calibrated to display the measured variable or control signal in engineering units. There are two basic design requirements:

1. The intrinsic safety output parameters of the 4-20 mA loop, which are defined by the Zener barrier or galvanic isolator powering the loop, must be equal to or less than:

$$\begin{aligned}
 U_o &= 30 \text{ V DC} \\
 I_o &= 200 \text{ mA} \\
 P_o &= 0.84 \text{ W}
 \end{aligned}$$

2. The loop must be able to tolerate the additional 1.2 V required to operate the I.S. Field Display. When fitted with an optional backlight this increases to 5 V if the backlight is loop-powered. See Section 3.4.1.

Figures 2 and 3 illustrate typical applications in which an I.S. Field Display is connected with an Easidew PRO I.S. and an Easidew TX I.S. transmitter powered by a galvanic isolator.

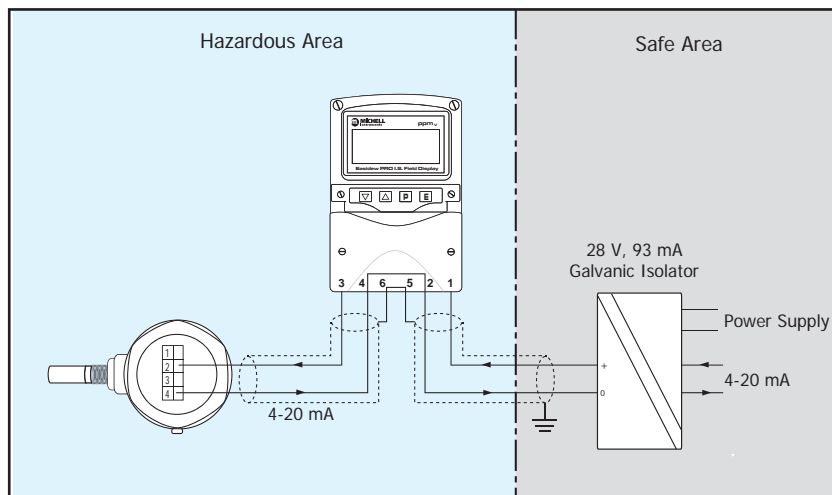

Figure 2 Loop-Powered by a Galvanic Isolator (Easidew PRO I.S.)

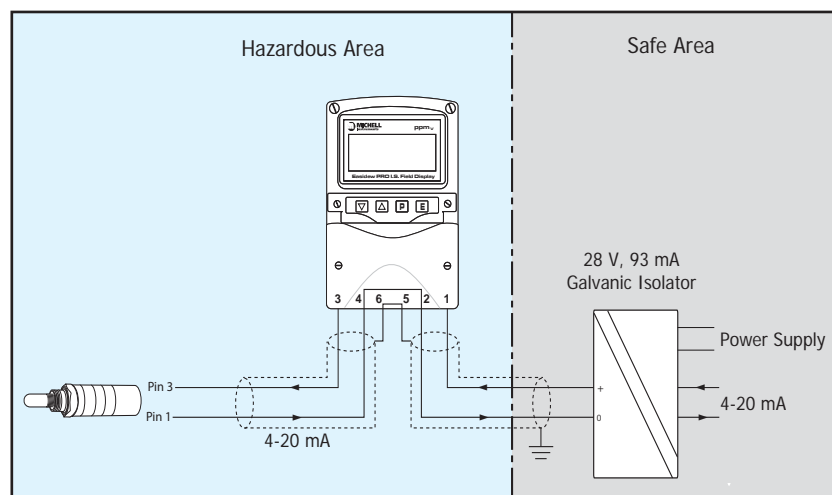

Figure 3 Loop-Powered by a Galvanic Isolator (Easidew TX I.S.)

2.2.2 Remote Indication

The I.S. Field Display may be used to provide a remote display within a hazardous area driven via an intrinsically safe interface from a 4-20 mA safe area signal. The type of intrinsically safe interface is not critical. Either a Zener barrier or a galvanic isolator may be used, providing that the  $U_i$ ,  $I_i$  and  $P_i$  of the I.S. Field Display are not exceeded and the voltage capability of the 4-20 mA signal is sufficient to drive the I.S. Field Display plus the interface.

When a high integrity earth connection is already available, a Zener barrier is usually the least expensive option. If an earth connection is not available or isolation is required, a galvanic isolator is the correct choice.

If one side of the 4-20 mA current loop may be earthed, a single channel Zener barrier provides the lowest cost protection. If the 4-20 mA signal is not isolated, then two Zener barriers, a two channel Zener barrier or a galvanic isolator must be used.

Figure 4 shows the alternative circuits which may be used.

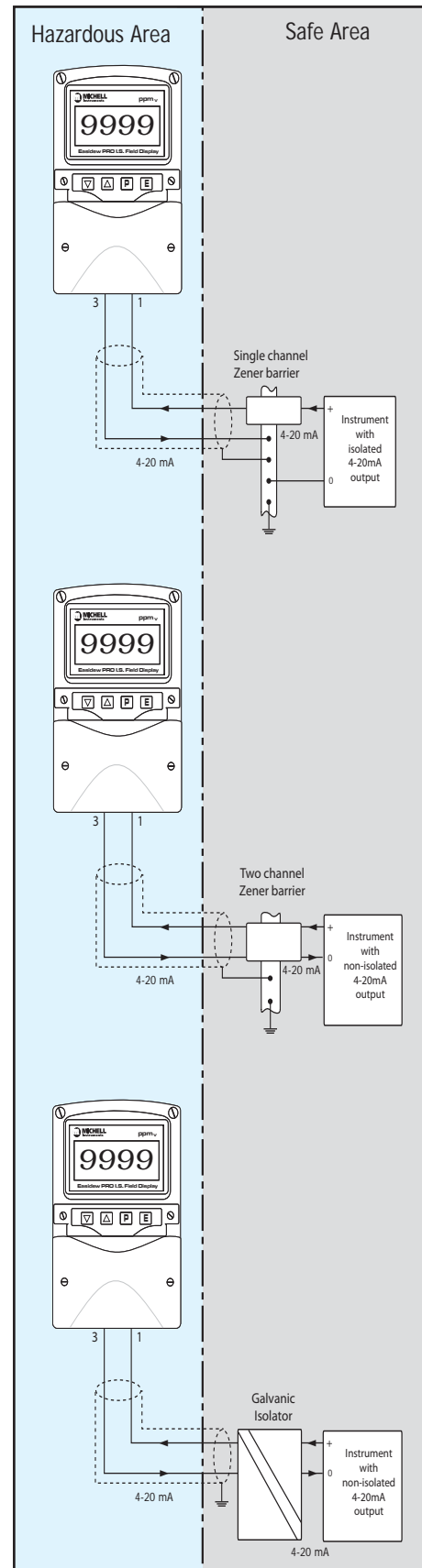

Figure 4 Alternative Circuits for Remote Indication in a Hazardous Area

2.3 Location

The I.S. Field Display is housed in a robust IP66 glass reinforced polyester (GRP) enclosure incorporating an armoured glass window and stainless steel fittings, making it suitable for exterior mounting in most industrial installations, including off-shore and waste water treatment. The I.S. Field Display should be positioned where the display is not in continuous direct sunlight.

The I.S. Field Display is surface mounted, but may be pipe mounted using the accessory kit described in Section 3.5 of this manual.

The field terminals and the two mounting holes are located in a separate compartment with a sealed cover, allowing the instrument to be installed without exposing the display assembly.

Terminals 2 and 4 are internally joined and may be used for linking the return 4-20 mA wire - see *Figure 3*. Similarly, terminals 5 and 6 are internally joined and may be used for linking cable screens. The I.S. Field Display's earth terminal is connected to the carbon-loaded GRP enclosure. If this enclosure is not bolted to an earthed post or structure, the earth terminal should be connected to the plant potential equalizing conductor.

The enclosures are fitted with a bonding plate to ensure electrical continuity between the three conduit / cable entries.

2.4 Installation Procedure

*Figure 5* illustrates the instrument installation procedure.

- a. Remove the instrument terminal cover by unscrewing the two captive 'A' screws.
- b. Mount the instrument on a flat surface and secure with screws or bolts through the two 'B' holes. Alternatively use the pipe or stem mounting kit described in Section 3.5.
- c. Remove the temporary dust seals from the three cable entries and install the required glands, conduit fittings or blanking plugs.

**NOTE: The temporary dust seals do not provide IP66 protection.**

- d. Connect the field wiring to the terminals as shown in *Figure 6*.
- e. Replace the instrument terminal cover and evenly tighten the two 'A' screws.

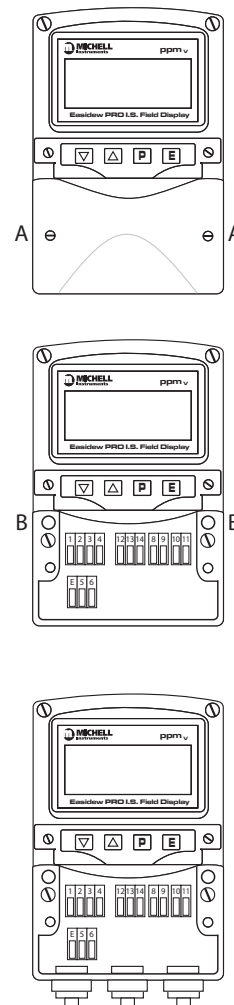

Figure 5 Installation Procedure

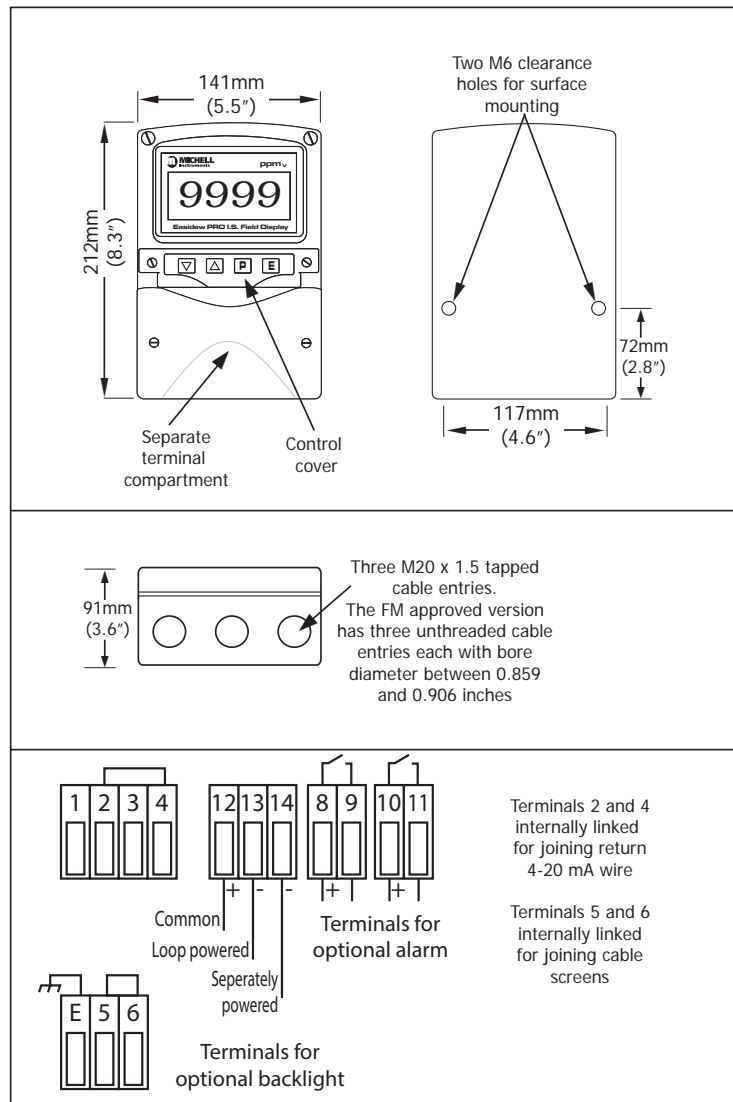

Figure 6 *Dimensions & Terminal Connections*

## 2.5 EMC

This instrument complies with the requirements of the European EMC Directive 2004/108/EC. For specified immunity all wiring should be in screened twisted pairs, with the screens earthed in the safe area.

### 3 OPERATION

The I.S. Field Display will be supplied already configured to order and only requires installation in the user's equipment. If it is necessary to re-range, change the resolution or set the alarms (if fitted), see the sections below:

#### 3.1 Configuration And Calibration

The I.S. Field Display is configured and calibrated via the four push-buttons which are located behind the control cover. All the configuration functions are contained in an easy-to-use intuitive menu that is shown diagrammatically in *Figure 7*.

Each menu function is summarized in Section 3.1.1 and includes a reference to more detailed information. When the I.S. Field Display is fitted with alarms, additional functions are added to the menu which are described in Section 3.3.

Throughout this manual, push-buttons are shown as **P**, **E**, **▲** or **▼**, and legends displayed by the I.S. Field Display are shown in bold type, e.g. **CAL** and **ALr2**.

Access to the Configuration Menu is obtained by pressing the **P** and **E** buttons simultaneously.

- If the I.S. Field Display security code is set to the default **0000**, the first parameter **FunC** will be displayed.
- If a security code other than the default code **0000** has already been entered, the I.S. Field Display will display **Code**.

Pressing **P** will clear this prompt allowing each digit of the code to be entered using **▲** and **▼**, and **P** to move control to the next digit.

When the correct four digit code has been entered, pressing **E** will cause the first parameter **FunC** to be displayed. If the code is incorrect, or a button is not pressed within twenty seconds, the I.S. Field Display will automatically return to the display mode.

Once within the Configuration Menu the required parameter can be reached by scrolling through the menu using **▲** and **▼** as shown in *Figure 7*. Pressing **E** will exit the Configuration Menu and return to the display mode. When returning to the display mode following recalibration or a change to any function, the I.S. Field Display will display **dAtA** followed by **SAVE** while the new information is stored in non-volatile memory.

All new I.S. Field Displays are supplied calibrated, as requested at the time of ordering. If calibration is not requested, indicators will be supplied with the following default configuration:

Default Configuration	
Access code <b>Code</b>	0000
Function <b>FunC</b>	Linear
Display at 4 mA <b>Zero</b>	0.00
Display at 20 mA <b>SPAn</b>	100.00
Resolution <b>rESn</b>	1 digit
<b>P</b> button in display mode <b>C - - P</b>	% (Input current)
Tare <b>tArE</b>	Off

### 3.1.1 Summary of Configuration Functions

This section summarizes each of the main configuration functions and includes a cross reference to a more detailed description. *Figure 7* illustrates the location of each function within the Configuration Menu.

**Display**    **Summary of function**

**FunC**      **Indicator function**

Defines the relationship between the 4-20 mA input current and the I.S. Field Display. May be set to:

<b>Std</b>	Standard linear relationship
<b>root</b>	Square root extraction
<b>Lin</b>	16 segment adjustable lineariser

See Section 3.1.2.

**rESn**      **Display resolution**

Defines the resolution of the least significant display digit. May be set to 1, 2, 3 or 10 digits. See Section 3.1.3.

**dP**        **Decimal point**

Positions a dummy decimal point between any of the digits or turns it off. See Section 3.1.4.

**CAL**      **Calibration of the digital display using an external current source**

Enables the zero and span of the I.S. Field Display to be adjusted using an external current source such as a calibrator. When used with an accurate traceable current source this is the preferred method of calibration. See Section 3.1.5.

**SEt**      **Calibration of display using internal references**

Enables the zero and span of the I.S. Field Display to be adjusted without the need for an accurate input current or disconnection from the 4-20 mA loop. See Section 3.1.6.

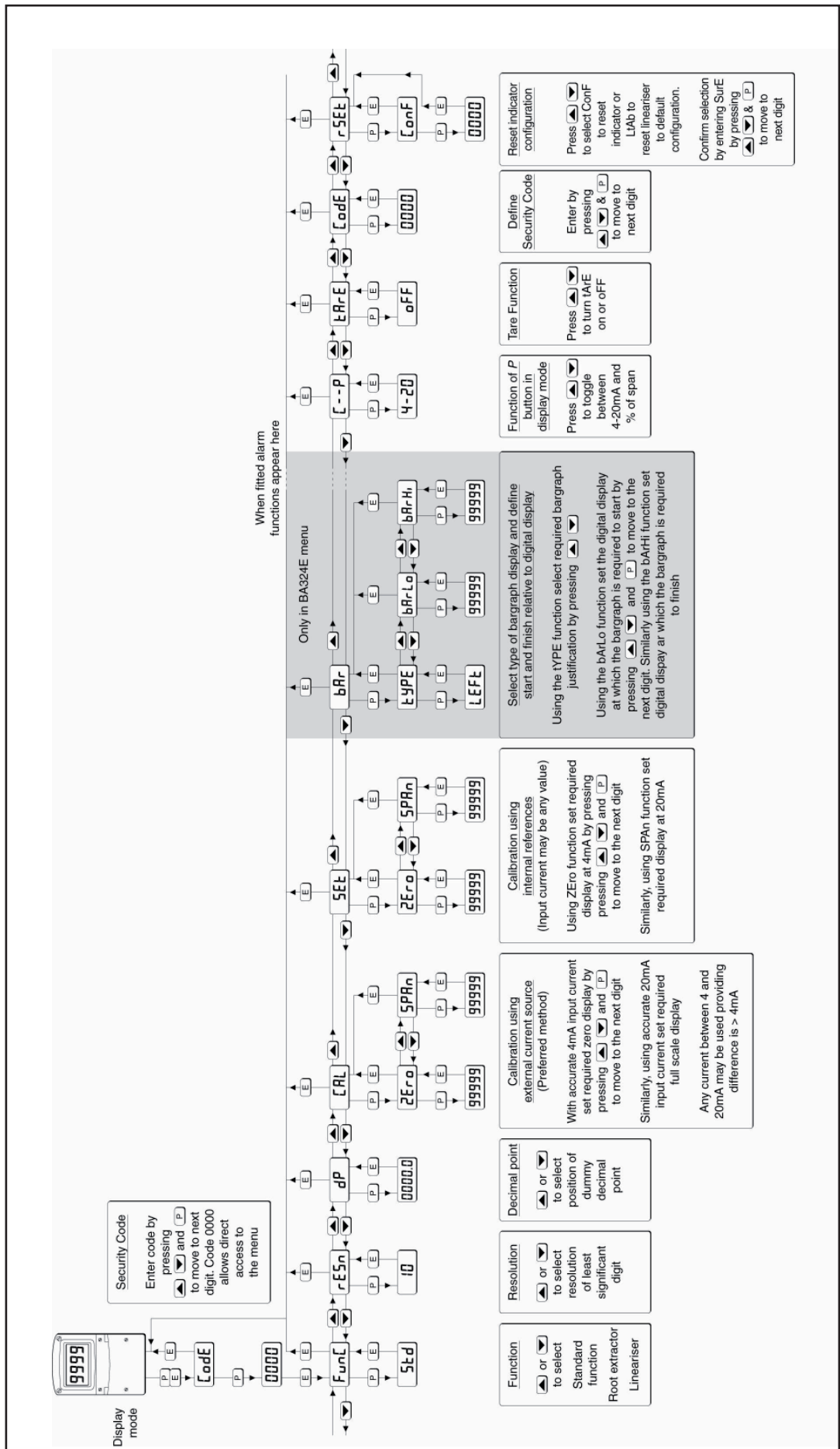

Figure 7 Configuration Menu



<b>Display</b>	<b>Summary of function</b>
<b>C - - P</b>	<p><b>Function of P button</b></p> <p>The I.S. Field Display may be configured to display the input current in milliamps, or the input current as a percentage of the 4-20 mA input, when <b>P</b> is pressed while in the display mode. See Section 3.1.7.</p>
<b>tArE</b>	<p><b>Tare function</b></p> <p>When enabled, the tare function sets the I.S. Field Display to zero when the <b>E</b> button is pressed in the display mode. See Section 3.1.8.</p>
<b>CodeE</b>	<p><b>Security code</b></p> <p>Defines a four-digit numeric code that must be entered to gain access to the Configuration Menu. Default code <b>0000</b> disables this security function and allows unrestricted access to all conditioning functions. See Section 3.1.9.</p>
<b>rSEt</b>	<p><b>Reset</b></p> <p>Contains two sub-functions, <b>ConF</b> which returns the I.S. Field Display to the default conditions shown in Section 3.1 and <b>LtAb</b> which returns the lineariser to the default conditions shown in Section 4.3. To prevent accidental use both resets must be confirmed by entering <b>5urE</b> before they will be executed. See Section 3.1.10.</p>

### 3.1.2 Indicator Function: 'Func'

This configuration function defines the relationship between the 4-20 mA input current and the I.S. Field Display. Three alternatives are available:

<b>Std</b>	Standard linear relationship - Default
<b>root</b>	Square root extraction
<b>Lin</b>	16 segment adjustable lineariser

To reveal the existing I.S. Field Display function, select **Func** from the Configuration Menu and press **P**. If the function is set as required, press **E** to return to the Configuration Menu, or press **▲** or **▼** to change the setting, followed by **E** to return to the Configuration Menu.

### 3.1.2.1 'Std' Linear (Default)

Provides a linear relationship between the 4-20 mA input current and the I.S. Field Display.

### 3.1.3 Resolution: 'rESn'

This function defines the resolution of the least significant display digit. Decreasing the display resolution can improve the readability of a noisy signal.

1. Select **rESn** from the menu.
2. Press **P** to reveal the current display resolution.
3. To change the resolution press **▲** or **▼** to select 1, 2, 5 or 10 digits.
4. Press **E** to enter the selection and return to the Configuration Menu.

### 3.1.4 Position of the Decimal Point: 'dP'

A dummy decimal point can be positioned between any of the digits, or it may be absent.

1. Select **dP** from the menu.
1. Press **P**.
2. Move the decimal point by pressing **▲** or **▼**.
3. If a decimal point is not required it should be positioned beyond the most or least significant digit.
4. When positioned as required, press **E** to enter the selection and return to the Configuration Menu.

### 3.1.5 Re-Range Display or Calibrate Using an External Current Source: 'CAL'

This function enables the zero and span of the I.S. Field Display to be adjusted using an external calibrated current source. When used with an accurate traceable current source this is the preferred method of calibration.

**ZERo (Zero)** is the display with 4 mA input

**SPAn (Span)** is the display with 20 mA input

To calibrate the I.S. Field Display:

#### ZERo

1. Select **CAL** from the Configuration Menu and press **P**. The instrument will display **ZERo** which is a request for a 4 mA input current.
2. Adjust the external current calibrator to 4.000 mA and press **P** to reveal the current zero display.
3. The flashing digit of the display can be changed by pressing **▲** or **▼**.
4. When set as required, press **P** to transfer control to the next digit.
5. When all the digits have been adjusted, press **E** to enter the new zero display and return to the **ZERo** prompt.

#### SPAn

6. Pressing **▲** from the **ZERo** prompt will cause the instrument to display **SPAn** which is a request for a 20 mA input current.
7. Adjust the external current calibrator to 20.000 mA and press **P** to reveal the current span display.
8. The flashing digit of the display can be changed by pressing **▲** or **▼**.
9. When set as required, press **P** to transfer control to the next digit.
10. When all the digits have been adjusted, press **E** to enter the new span and return to the **SPAn** prompt.
11. Press **E** to return to the Configuration Menu.

#### NOTES:

- The I.S. Field Display input current must be adjusted to the required value before the zero and span functions are entered, by pressing **P**.
- Indicators may be calibrated at currents other than 4 and 20 mA, within the range 3.8 to 21.0 mA, providing the difference between the two currents is greater than 4 mA. If these conditions are not complied with, the I.S. Field Display displays **FaiL** and aborts the calibration.
- If the zero current is greater than the span current the instrument will be reverse acting, i.e. an increasing input current will cause the display to decrease.

### 3.1.6 Re-Range Display or Calibrate Using Internal Reference: 'SEt'

Using the **SEt** function the I.S. Field Display can be calibrated without the need to know the value of the 4-20 mA input current, or to disconnect the instrument from the 4-20 mA loop.

When using the **SEt** function the I.S. Field Display's internal reference is used to simulate a 4 mA and 20 mA input current.

**ZErO (Zero)** is the display with a simulated 4 mA input

**SPAn (Span)** is the display with a simulated 20 mA input

To calibrate the I.S. Field Display:

#### **ZErO**

1. To adjust at 4 mA input select **SEt** from the Configuration Menu and press **P**. The instrument will display **ZErO**.
2. Press **P** again to reveal the current display at 4 mA.
3. The flashing digit can be adjusted by pressing **▲** or **▼**.
4. When the flashing digit is correct, press **P** to transfer control to the next digit.
5. When all the digits have been adjusted, press **E** to return to the **ZErO** prompt.

#### **SPAn**

6. To adjust at 20 mA, press **▲** from the **ZErO** prompt which will cause the instrument to display **SPAn**.
7. Press **P** to reveal the instrument's existing display at 20 mA.
8. The flashing digit can be adjusted by pressing **▲** or **▼**.
9. When the flashing digit is correct, press **P** to transfer control to the next digit.
10. When all the digits have been adjusted, press **E** to return to the **SPAn** prompt
11. Press **E** to return to the **SEt** prompt in the Configuration Menu.

### 3.1.7 Function of the P Push-Button: 'C - - P'

When the I.S. Field Display is in the display mode, pressing **P** will display the input current in milliamps, or the displayed value as a percentage of the difference between the displayed values at 4 mA and 20 mA inputs.

To check or change the function of the **P** button, select **C - - P** from the Configuration Menu and press **P** to reveal the current setting. Pressing **▲** or **▼** will toggle the setting between **4-20** (the current display in milliamps) and **PC** (the percentage display). When set as required, press **E** to return to the **C - - P** prompt in the Configuration Menu.

### 3.1.8 Tare Function: 'tArE'

The tare function is primarily intended for use with a weighing system.

### 3.1.9 Security Code: 'CodE'

Access to the instrument Configuration Menu may be protected by a four-digit security code which must be entered to gain access. New instruments are configured with the default security code **0000** which allows unrestricted access to all configuration functions.

To enter a new security code, select **CodE** from the Configuration Menu and press **P** which will cause the instrument to display the existing security code with one digit flashing. The flashing digit can be adjusted using **▲** or **▼**. When set as required, pressing **P** will transfer control to the next digit. When all the digits have been adjusted, press **E** to return to the **CodE** prompt in the Configuration Menu. The revised security code will be activated when the I.S. Field Display is returned to the display mode. Please contact Michell Instruments (see contact details at [www.michell.com](http://www.michell.com)) if the security code is lost.

### 3.1.10 Reset to Factory Defaults: 'rSEt'

This function enables the I.S. Field Display and the lineariser to be quickly returned to the factory default configurations shown in Section 3.1.

To reset the I.S. Field Display or lineariser, select **rSEt** from the Configuration Menu and press **P**. The instrument will display one of the reset options **ConF** or **LtAb**.

<b>ConF</b>	Resets the I.S. Field Display to defaults
<b>LtAb</b>	Resets the lineariser to defaults

Using **▲** or **▼**, select the required sub-function and press **P**. To prevent accidental resetting the request must be confirmed by entering **5urE**. Using **▲**, set the first flashing digit to **5** and press **P** to transfer control to the second digit which should be set to **u**. When **5urE** has been entered, press **E** to reset the selected Configuration Menus and return the display to the **rSEt** function in the Configuration Menu.

### 3.1.11 Under and Over-Range

If the numerical display range of the I.S. Field Display is exceeded, all the decimal points will flash as shown below:

Under range	-9.9.9.9
Over range	9.9.9.9

Although not guaranteed, most indicators will continue to function normally with an input current between 1.8 mA and 4 mA. At lower currents the instrument will display **LPLo** before it stops functioning.

## 3.2 External Keypad (Optional)

The four push-buttons are located behind the instrument control cover. For applications requiring frequent adjustment, an optional control cover fitted with an external keypad is available. This keypad maintains the enclosure ingress protection and accidental push button activation can be prevented by use of a menu security access code, see Section 3.1.9.

3.3 Alarms (Optional)



**CAUTION:**  
**These alarms outputs should NOT be used for critical safety applications such as an emergency shut down system.**

The I.S. Field Display can be supplied with factory-fitted dual solid state, single pole alarm outputs. Each alarm output may be independently conditioned as a high or low alarm with a normally open or normally closed output in the non-alarm condition.

When the 4-20 mA current powering the I.S. Field Display is removed, both alarm outputs will open irrespective of configuration. The open circuit condition should therefore be chosen as the alarm condition when designing an alarm system. *Figure 8* illustrates the conditions available and shows which are fail safe.

When an alarm occurs, an alarm annunciator on the front panel is activated and, if required, the numerical display can alternate between the measured value and the alarm channel identification **ALr1** or **ALr2**.



**The alarms are activated by the I.S. Field Display's numerical display. Use of the Tare Function tArE will change the numerical display - the alarms will continue to function at the original displayed value, but this will correspond to a different input current.**

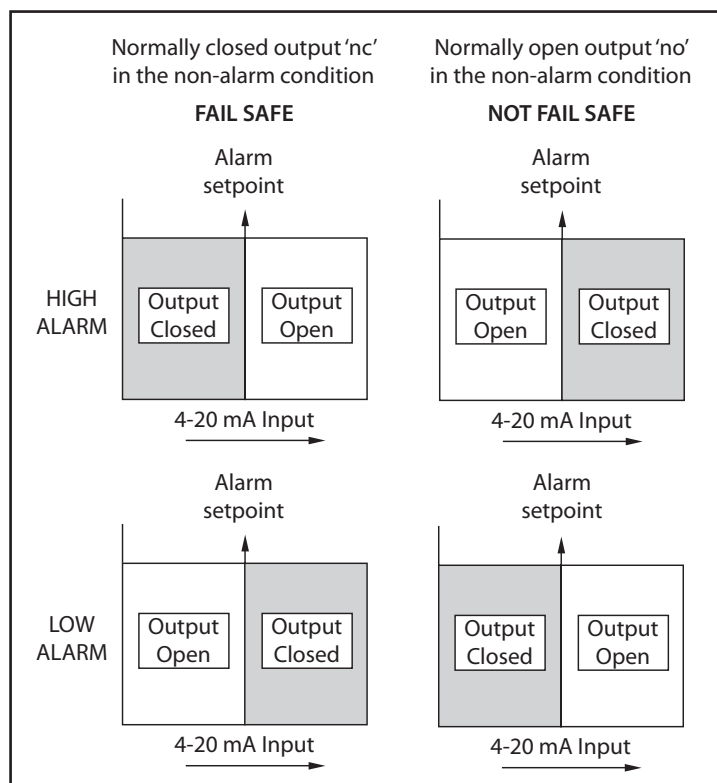

Figure 8 Alarm Outputs

Configurable functions for each alarm include adjustable setpoint, hysteresis, alarm delay and alarm accept.

3.3.1 Solid State Output

Each alarm has a galvanically isolated single pole solid state switch output which is shown in *Figure 9*. The output is polarized and current will only flow in one direction.

- Ron = less than  $5 \Omega + 0.7 \text{ V}$
- Roff = greater than  $1 \text{ M} \Omega$

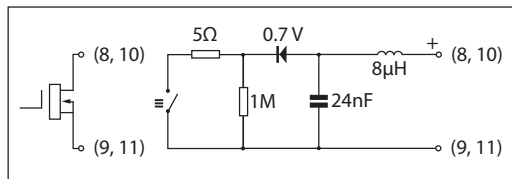

Figure 9 Equivalent Circuit of Each Alarm Output

3.3.2 Intrinsic Safety

Each alarm output is a separate galvanically isolated intrinsically safe circuit. The EC-Type Examination Certificate states that for intrinsic safety considerations, under fault conditions, the output voltage, current, and power at terminals 8 & 9 and 10 & 11 will not exceed those specified by clause 5.7 of EN 60079-11 for simple apparatus. This simplifies system documentation and allows the alarm output terminals 8 & 9 and 10 & 11 to be connected to almost any intrinsically safe circuit protected by a Zener barrier, or galvanic isolator, providing the output parameters of the circuit do not exceed:

- Uo = 30 V DC
- Io = 200 mA
- Po = 0.84 W

The maximum equivalent capacitance and inductance between each set of alarm terminals is:

- Ci = 24nF
- Li = 8μH

To determine the maximum permissible cable parameters these figures should be subtracted from the maximum permitted cable capacitance and inductance specified by the certificate powering the alarm circuit, such as the solenoid driver and switch transfer galvanic isolators shown in *Figure 10*.

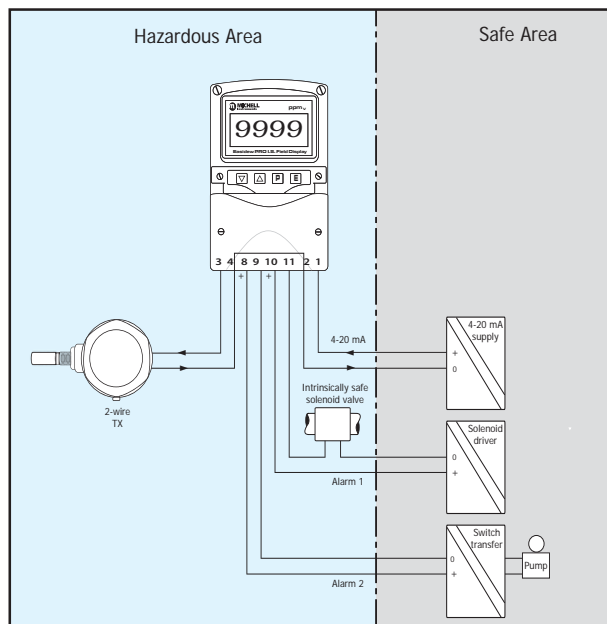

Figure 10 Typical Alarm Application  
(Shown without recommended screened cables)



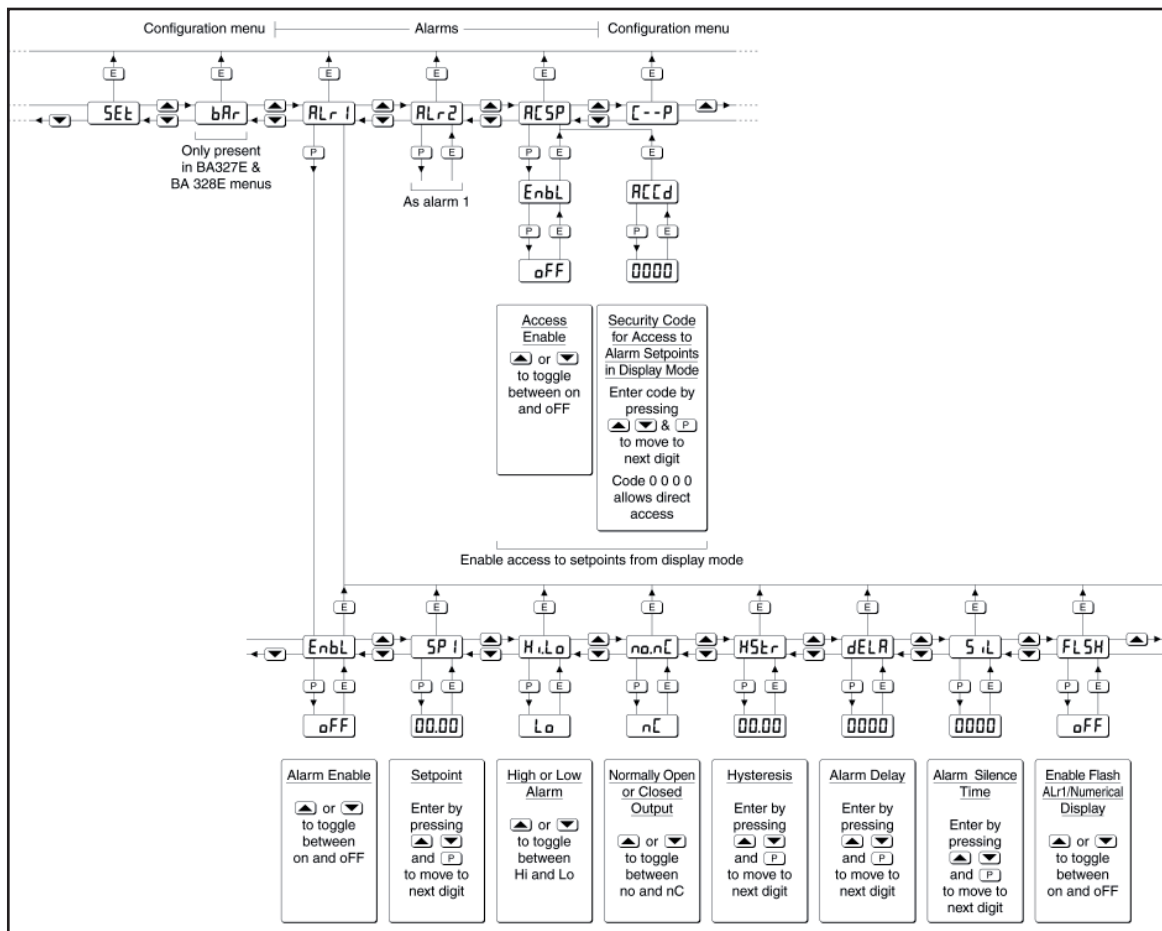

Figure 11 Alarm Configuration Functions in Configuration Menu

### 3.3.3 Configuration and Adjustment

When optional alarms are fitted to an I.S. Field Display, the Configuration Menu is extended as shown in *Figure 11*. The additional functions appear between the **SEt** and the **C - - P** functions. For simplicity, *Figure 11* only shows the additional functions for Alarm 1, but Alarm 2 has identical functions.

The following table summarizes each of the alarm configuration functions and includes a cross reference to more detailed information. Again, only the functions on Alarm 1 are listed, but Alarm 2 has identical facilities.

To access the alarm functions:

1. Press the **P** and **E** buttons simultaneously.
2. Press ▲ 5 times until **Alr1** is shown.
3. Press **P** again.

Summary of alarm configuration functions:

<b>Display</b>	<b>Description of function</b>
----------------	--------------------------------

<b>EnbL</b>	<b>Alarm enable</b> Enables or disables the alarm without changing the alarm parameters. See Section 3.3.4.
-------------	---

<b>SP1</b>	<b>Alarm setpoint 1</b> Adjusts the alarm setpoint. The alarm is activated when the display equals the setpoint. See Section 3.3.5.
<b>Hi.Lo</b>	<b>Alarm function</b> Defines the alarm function as High or Low. See Section 3.3.6.
<b>no.nC</b>	<b>Normally open or normally closed output</b> Sets the alarm output open or closed in the non-alarm condition. See Section 3.3.7.
<b>HStr</b>	<b>Hysteresis</b> Adjusts the alarm hysteresis. See Section 3.3.8.
<b>dELA</b>	<b>Alarm delay time</b> Introduces adjustable delay between the display equalling the setpoint and the alarm output being activated. See Section 3.3.9.
<b>SiL</b>	<b>Alarm silence time</b> Defines the time that the alarm output remains in the non-alarm condition following acceptance of an alarm. See Section 3.3.10.
<b>FLSH</b>	<b>Flash display when alarm occurs</b> When enabled, alternates the numerical display between process value and alarm reference, <b>ALr1</b> or <b>ALr2</b> , when an alarm output is activated. See Section 3.3.11.
<b>ACSP</b>	<b>Access setpoint</b> Sub-menu which enables direct access to the alarm setpoints from the display mode, and defines a separate security code. See Section 3.3.12.

### 3.3.4 Alarm Enable: 'EnbL'

This function allows each alarm to be enabled or disabled without altering any of the alarm parameters. To enable or disable the alarm select **EnbL** from the Alarm Menu and press **P** to reveal the current setting **on** or **off**. The function can be changed by pressing **▲** or **▼** followed by **E** to return to the Alarm Menu.

### 3.3.5 Setpoint Adjustment: 'SP1' and 'SP2'

The setpoint of each alarm may be positioned anywhere in the numerical display of the I.S. Field Display providing that this corresponds to an input current between 3.8 and 20.2 mA. For example, if the I.S. Field Display has been calibrated to display 0 with 4 mA input and 10000 with 20 mA input, the two alarm setpoints may be positioned anywhere between -125 and 10125.

To adjust the setpoint select **SP1** or **SP2** from the Alarm Menu and press **P** which will reveal the existing alarm setpoint. The flashing digit of the setpoint can be adjusted using **▲** and **▼**, and **P** to move control to the next digit. When the required setpoint has been entered, press **E** to return to the Alarm Menu.

The alarm setpoints may also be adjusted when the I.S. Field Display is in the display mode. See Section 3.3.12.

### 3.3.6 Alarm Function: 'Hi.Lo'

Each alarm can be independently conditioned as a high alarm or a low alarm. To check or change the alarm function select **Hi.Lo** from the Alarm Menu and press **P** to reveal the current setting. The function can be changed by pressing **▲** or **▼** followed by **E** to return to the Alarm Menu.

### 3.3.7 Alarm Output Status: 'no.nC'

Configures the solid state alarm output to be open **no** or to be closed **nC** in the non-alarm condition. When deciding which is required, care should be taken to ensure that the alarm output is fail safe as illustrated in *Figure 8*.

<b>no</b>	Alarm output open in non-alarm condition
<b>nC</b>	Alarm output closed in non-alarm condition



**When the 4-20 mA supply is removed from the loop-powered I.S. Field Display, both alarm outputs will open irrespective of conditioning. Therefore, for fail safe operation both alarm outputs should be conditioned to be open in the alarm condition nC.**

To check or change the alarm output status, select **no.nC** from the Alarm Menu and press **P** to reveal the setting. The function may be changed by pressing **▲** or **▼** followed by **E** to return to the Alarm Menu.

### 3.3.8 Hysteresis: 'HStr'

Hysteresis is shown in the units that the I.S. Field Display has been calibrated to display.

To adjust the hysteresis select **HStr** from the Alarm Menu and press **P** which will reveal the existing figure. The flashing digit can be adjusted using **▲** and **▼**, and **P** will move control to the next digit. When the required hysteresis has been entered, press **E** to return to the Alarm Menu.

For example, a Field Display calibrated to display 0 to 10000, with a high alarm set at 9000 and hysteresis of 200 will perform as follows:

The high alarm will be activated when increasing display equals 9000, but will not reset until the display falls below 8800.

### 3.3.9 Alarm Delay: 'dELA'

This function delays activation of the alarm output for an adjustable time following the alarm condition occurring. The delay can be set in 1 second increments between 0 and 3600 seconds. If a delay is not required, zero should be entered. To adjust the delay select **dELA** from the Alarm Menu and press **P** which will reveal the existing delay. The flashing digit of the delay can be adjusted using **▲** and **▼**, and **P** to move control to the other digits. When the required delay has been entered, press **E** to return to the Alarm Menu.

For example, a Field Display with a high alarm set at 9000 and an alarm delay of 30 seconds will perform as follows:

The alarm annunciator will start to flash when an increasing display equals 9000, but the alarm output will not be activated until the alarm condition has existed continuously for 30 seconds. When the alarm output is activated, the alarm annunciator will stop flashing and become permanently activated.

If the **FLSH** function, which flashes the display when an alarm occurs, has been enabled, it will not start to function until the alarm output is activated. See Section 3.3.11.

### 3.3.10 Alarm Silence Time: 'SiL'

This function is primarily intended for use in small installations where the alarm output directly operates an alarm annunciator such as a sounder or beacon. When the alarm silence time, which is adjustable between 0 and 3600 seconds in 1 second increments, is set to any figure other than zero, **P** becomes an alarm accept button. After an alarm has occurred, pressing **P** will cause the alarm output to revert to the non-alarm condition for the programmed alarm silence time. If the alarm condition still exists at the end of the silence time, the alarm output will be reactivated. During the silence time the I.S. Field Display alarm annunciator will flash until the silence time expires or the alarm is cleared.

The **FLSH** function, which flashes the display when an alarm occurs has been enabled, will only function when the alarm output is activated, not during the silence time. See Section 3.3.11.

To adjust the alarm silence time, select **SiL** from the Alarm Menu and press **P** which will reveal the existing silence time. The flashing digit of the silence time can be adjusted using **▲** and **▼**, and **P** to move control to the other digits. When the required silence time has been entered, press **E** to return to the Alarm Menu.

### 3.3.11 Flash Display when Alarm Occurs: 'FLSH'

In addition to the two alarm annunciators on the top left hand corner of the display which show the status of both alarms, this function provides an even more conspicuous indication that an alarm condition has occurred.

When enabled, the function alternates the display between the numerical value and the alarm reference, **ALr1** or **ALr2**, when the alarm output is activated. If both alarm outputs are activated, the alarm references are displayed in sequence.

To enable or disable the function select **FLSH** from the Alarm Menu and press **P** which will reveal the current setting **on** or **oFF**. The function can be changed by pressing **▲** or **▼** followed by **E** to return to the Alarm Menu.

### 3.3.12 Access Setpoint in Display Mode: 'ACSP'

This function enables a separate menu providing access to the alarm setpoints from the display mode by simultaneously pressing **P** and **▲**. An operator can therefore adjust the alarm setpoints without having access to the I.S. Field Display Configuration Menu. Protection against accidental adjustment of the setpoints, when the I.S. Field Display is in the display mode, is provided by a separate security code.

This direct setpoint access menu is enabled and the separate security code entered from the **ACSP** function as shown in *Figure 11*.

To enable/disable **ACSP**:

1. Press the **P** and **E** buttons simultaneously.
2. Press **▲** 7 times until **ACSP** is shown.
3. Press **P** to display the enable prompt **EnbL**.
4. Press **P** again to reveal if the direct access menu is **on** or **oFF**. **▲** or **▼** will toggle the display between the two conditions.

If **oFF** is selected, the operator will not have access to the setpoints from the display mode. Return to the **ACSP** prompt in the main menu by pressing **E** twice.

If **on** is selected, the operator will have direct access to the alarm setpoints from the display mode via a separate optional security code. To define this four digit security code:

1. Press **P** to return to the **EnbL** prompt followed by **▲** or **▼** to select the access code prompt **ACCd**.
2. Pressing **P** will reveal the current security code. Each digit of the code may be changed by pressing **▲** and **▼**, and **P** to move control to the next digit.
3. When the required code has been entered, press **E** twice to return to the **ACSP** prompt in the Configuration Menu.

Default code **0000** will disable the security code allowing direct access to the setpoints in the display mode by pressing **P** and **▲** simultaneously. Unless otherwise requested, new instruments with alarms are supplied with this function disabled and the security code set to **0000**.

### 3.3.13 Adjusting Alarm Setpoints from the Display Mode

**NOTE:** With the I.S. Field Display in the display mode, direct access to the alarm setpoints is only available when the ACSP menu is enabled, see Section 3.3.12.

**NOTE:** ONLY the setpoints are adjustable from this menu. To change any other alarm settings such as Hysteresis or Delay Time refer to Section 3.3.3.

Access to the alarm setpoints from the instrument display mode is obtained as follows:

1. Press **P** and **▲** simultaneously. If the setpoints are not protected by a security code the alarm setpoint prompt **SP1** will be displayed. If the setpoints are protected by a security code, **Code** will be displayed first.
2. Press **P** to enable the alarm security code to be entered, digit by digit, using **▲** and **▼** to change the flashing digit, and **P** to move control to the next digit.
3. When the correct code is entered, pressing **E** will cause the alarm setpoint prompt **SP1** to be displayed.
4. Pressing **▲** or **▼** will toggle the display between the two alarm setpoint prompts **SP1** and **SP2**.

**NOTE:** If an incorrect security code is entered, or a button is not pressed within twenty seconds, the I.S. Field Display will automatically return to the display mode.

To adjust an alarm setpoint:

1. Select **SP1** or **SP2** and press **P** to reveal the current setting.
2. Each digit of the setpoint may be adjusted using **▲** and **▼**, and **P** to move control to the next digit.
3. When the required setpoint has been entered, press **E** to return the display to the **SP1** or **SP2** prompt from which the other setpoint may be selected.
4. After making all adjustments the I.S. Field Display may be returned to the display mode by pressing **E** again.

### 3.4 Display Backlight (Optional)

The I.S. Field Display can be supplied with a factory-fitted backlight that may be loop or separately powered.

When loop-powered, the backlight produces green background illumination enabling the display to be read at night or in poor lighting conditions. No additional power supply, intrinsic safety interface or field wiring is required, but the I.S. Field Display voltage drop is increased. When separately powered, the backlight is brighter, but an additional intrinsic safety interface and field wiring are required.

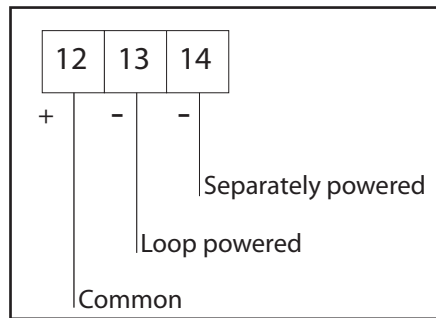

Figure 12 Terminals for Optional Backlight

#### 3.4.1 Loop Powering the Backlight

The backlight is loop-powered by connecting it in series with the I.S. Field Display's 4-20 mA input as shown in *Figure 13*, which increases the maximum Field Display voltage drop from 1.2 to 5 V.

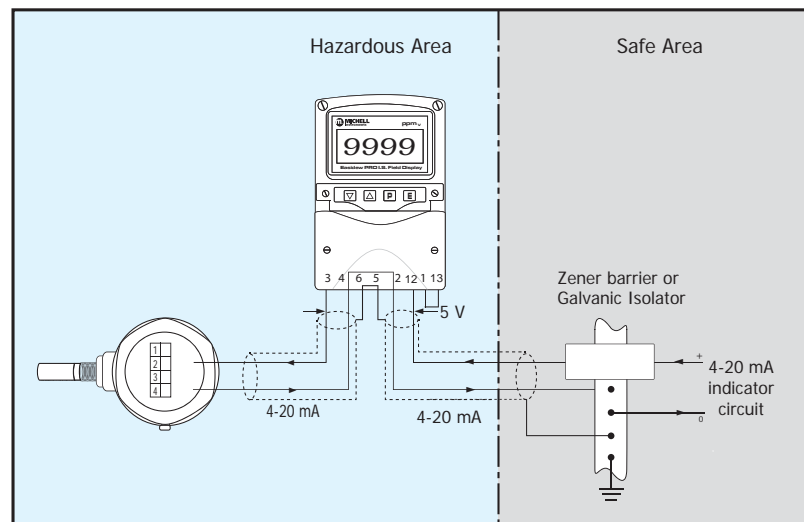

Figure 13 Loop-Powered Backlight

The input intrinsic safety parameters of the combined I.S. Field Display and backlight are the same as for the I.S. Field Display alone. The EC-Type Examination Certificate states that for intrinsic safety considerations, under fault conditions, the output voltage, current and power of the combined I.S. Field Display and backlight terminals 12 & 3 will not exceed those specified by clause 5.7 of EN 60079-11 for simple apparatus, which simplifies system design and documentation.

### 3.4.2 Separately Powering the Backlight

The optional backlight may also be powered from a separate safe area power supply via an intrinsically safe interface, as shown in *Figure 14*.

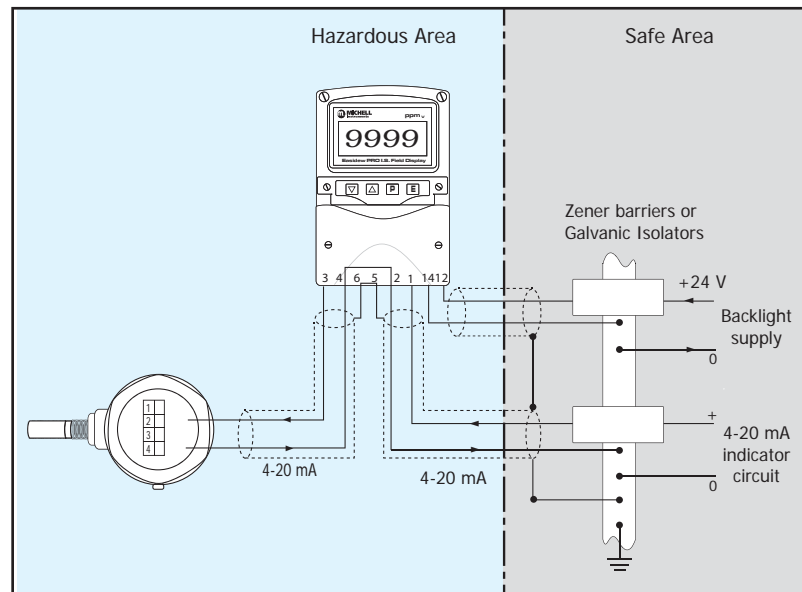

Figure 14 Separately Powered Backlight

When separately powered, the backlight draws a constant current when the supply is equal to or greater than the minimum specified voltage. Below this supply voltage the backlight continues to function, but with reduced brilliance.

**Current      Minimum voltage**

34.7 mA      11 V

Any certified Zener barrier or galvanic isolator may be used, providing the output parameters do not exceed:

$U_o = 30 \text{ V DC}$   
 $I_o = 200 \text{ mA}$   
 $P_o = 0.84 \text{ W}$

The following equivalent internal capacitance and inductance between terminals 12 & 14 should be subtracted from  $C_o$  and  $L_o$  of the intrinsically safe interface powering the backlight to provide the maximum permissible cable parameters.

$C_i = 13\text{nF}$   
 $L_i = 8\mu\text{H}$

The separately powered backlight is a current sink which will draw a constant 35 mA when the voltage between terminal 12 and 14 is greater than 11 V. If the supply voltage is less than 11 V the backlight brilliance will be reduced.



### 3.5 Pipe-Mounting Kits

A pipe-mounting kit is available for securing the I.S. Field Display to a horizontal or vertical pipe.

EPD-PMK Stainless steel bracket secured by two worm drive hose clips. Will clamp to any vertical OR horizontal pipe with an outside diameter between 60 and 80mm.

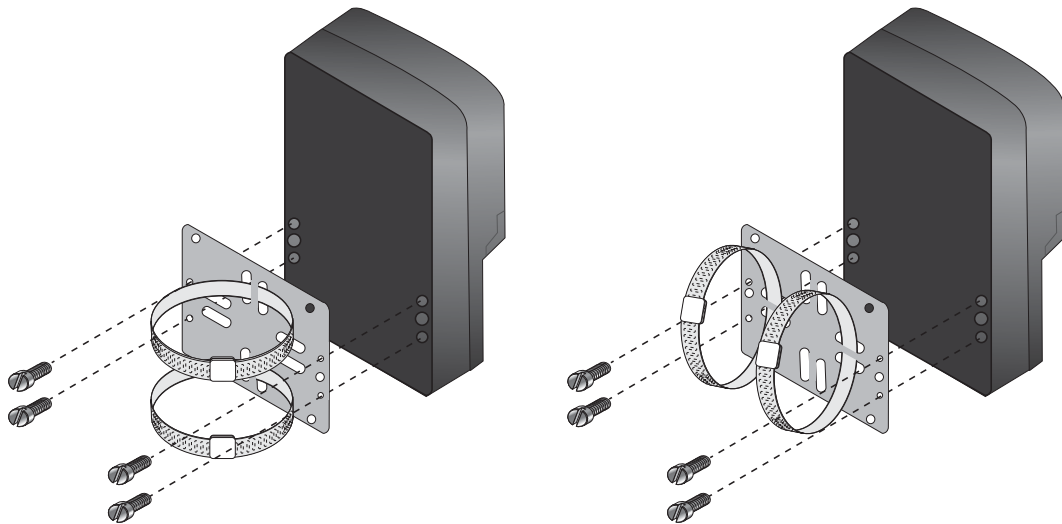

Figure 15 *Pipe-Mounting Kit*

#### Assembly Procedure

1. Completely unscrew both hose clips and thread them through the horizontal or vertical slots in the mounting plate.
2. Pass the hose clips around the pipe to which the instrument is to be mounted, re-engage both clips and tighten after turning the mounting plate into the required position.
3. Fix the instrument to the mounting plate using four locally sourced 4mm x 12mm long, self-tapping screws.

## 4 MAINTENANCE

### 4.1 Fault Finding During Commissioning

If the I.S. Field Display fails to function during commissioning, the following procedure should be followed:

Symptom	Cause	Solution
No display	Incorrect wiring	Check wiring There should be 0.6 to 1.2 V between terminals 1 & 3 with terminal 1 positive With an optional loop-powered backlight, there should be 3.4 to 5 V between terminals 1 & 13 with terminal 1 positive
No display 0 V between terminals 1 & 3	Incorrect wiring or no power supply	Check supply voltage and voltage drop caused by all the instruments in the loop
All decimal points flashing	Under range if -ve sign displayed or over range	Recalibrate the numerical display
Unstable display	4-20 mA input is noisy	Eliminate ripple on 4-20 mA power supply and/or decrease resolution
Unable to enter Configuration Menu	Incorrect security code entered	Enter correct security code, or contact Michell Instruments if the code has been lost

### 4.2 Fault Finding After Commissioning



**Ensure plant safety before starting maintenance.**

Live maintenance is permitted on intrinsically safe equipment installed in a gas hazardous area, but only certified test equipment should be used unless a gas clearance certificate is available.

If an I.S. Field Display fails after it has been functioning correctly follow the procedure shown in Section 4.1. If this does not reveal the cause of the fault, it is recommended that the instrument is replaced. This can be done without disconnecting power, but while the I.S. Field Display is disconnected the 4-20 mA loop will be open circuit.

### 4.3 Servicing

All I.S. Field Displays are interchangeable if the required optional backlight and alarms are fitted. A single spare instrument may quickly be recalibrated to replace any instrument that is damaged or fails. No attempt should be made to repair instruments at component level.

It is recommended that faulty instruments are returned to Michell Instruments or to a local Michell Instrument's agent for repair.

### 4.4 Routine Maintenance

The mechanical condition of the instrument and electrical calibration should be regularly checked. The interval between inspections depends upon environmental conditions. It is recommended that, initially, instrument calibration should be checked annually.

# Appendix A

## Hazardous Area Certification

## Appendix A Hazardous Area Certification

### A.1 ATEX Certification

The I.S. Field Display is available with ATEX Gas & Dust Certification. Dust certification is an option which must be specified when the I.S. Field Display is ordered.

#### Hazardous Area Certification

The I.S. Field Display is certified compliant to the ATEX Directive (94/9/EC), and IECEx for use within Zone 0, 1 and 2 hazardous areas and has been assessed so by ITS (Notified Body 0359).

The I.S. Field Display is certified compliant to the North American Standards (USA and Canada) for use within hazardous locations (see specific locations below) and has been assessed so by FM.

### A.2 Product Standards

This product conforms to the Standards:

EN60079-0:2009	IEC60079-0:2007-10
EN60079-11:2012	IEC60079-11:2006
EN60079-26:2007	IEC60079-26:2006
ANSI/IEC 60529:2004	IEC61241-11:2005
FM CLASS 3600:2011	CAN/CSA-C22.2 No.94 02 2007
FM CLASS 3610:2010	CAN/CSA-C22.2 No.157 1992
FM CLASS 3611:2004	CAN/CSA-C22.2 No. 213 1987
FM CLASS 3810:2005	CAN/CSA-C22.2 E60079-11-02 2002
C22.2 No. 61010.1 2004	C22.2 NO. 60079-0-07 2007

### A.3 Product Certification

This product is attributed with the product certification codes:

#### ATEX & IECEx

**II 1 G Ex ia IIC T5 Ga, (-40°C to +70°C)**

**II 1 D Ex ia IIIC T80°C Da IP66 (-40°C to +70°C)**

#### North American

**IS, Class I, Division 1, Groups A, B, C, D, T4**

**Non-Incendive Class I, Division 2, Groups A, B, C, D, T4**

**IS / I, II, III / A, B, C, D, E, F, G / T4 Ta = 70°C – Entity; CI300-72; 4X; IP66**

**I / 0 / Ex ia IIC / T4 Ta = 70°C – Entity; CI300-72**

**NI / I / 2 / ABCD / T4 Ta = 70°C – NIFW ; CI300-73**

**NI / II / 2 / EFG / T4 Ta = 70°C – NIFW ; CI300-73**

**NI / III / T4 Ta = 70°C – NIFW ; CI300-73**

**I / 2 / IIC / T4 Ta = 70°C – NIFW ; CI300-73**

#### A.4 Global Certificates/Approvals

ATEX	ITS11ATEX27253
IECEX	IECEX ITS 11.0014
FM	3041487
cFM	3041487C

These certificates can be viewed or downloaded from our website at:  
<http://www.michell.com>

#### A.5 Input Terminal Parameters

Refer to certificates for the listing of the permitted Input parameters.

#### A.6 Special Conditions

None

#### A.7 Non- Incendive

##### N. American Non-Incendive approval

The I.S. Field Display is also approved to non-Incendive standard FM Class 3611 allowing installation in Division 2 hazardous (classified) locations without the need for Zener barriers or galvanic isolators. US installations must comply with the Control Drawing CI300-73, which is attached to this Appendix, and with the National Electrical Code ANSI/NFPA70.

Canadian non-Incendive installations must comply with the Canadian Electrical Code C22.2 and with Control Drawing CI300-73, which is attached to this Appendix.

#### A.8 Maintenance and Installation

The I.S. Field Display must only be installed by suitably qualified personnel and in accordance with the instructions provided and the terms of the applicable product certificates.

Maintenance and servicing of the product must only be carried out by suitably trained personnel or returned to an approved Michell Instruments' Service Center.



Iss.	Date	Modification	Ckd.	Appd.	<p><b>Notes</b></p> <ol style="list-style-type: none"> <li>The associated protective barriers and galvanic isolators shall be FM approved and the manufacturers instructions shall be followed when installing this equipment. For installations in Canada the associated protective barriers and galvanic isolators shall be cFM or CSA approved and the manufacturers installation drawings shall be followed when installing this equipment.</li> <li>The unclassified location equipment shall not use or generate more than 250V rms or 250V dc.</li> <li>Installations shall be in accordance with ANSI/ISA RP 12.06.01 'Installation of Intrinsically Safe Systems for Hazardous (Classified) Locations' and the National Electrical Code ANSI/NFPA 70. Installations in Canada shall be in accordance with the Canadian Electrical Code C22.2.</li> <li>One single channel or one two channel associated protective barrier or galvanic isolator with entity parameters complying with the following requirements:                     <table border="0" style="margin-left: 20px;"> <tr> <td style="padding-right: 20px;"><math>U_o</math></td> <td style="padding-right: 20px;">equal or less than</td> <td>The lowest <math>U_i</math> of the FM, cFM or CSA approved apparatus installed in the loop.</td> </tr> <tr> <td><math>I_o</math></td> <td>equal or less than</td> <td>The lowest <math>I_i</math> of the FM, cFM or CSA approved apparatus installed in the loop.</td> </tr> <tr> <td><math>P_o</math></td> <td>equal or less than</td> <td>The lowest <math>P_i</math> of the FM, cFM or CSA approved apparatus installed in the loop.</td> </tr> <tr> <td><math>L_o</math></td> <td>equal or greater than</td> <td>The sum of the cable inductances and the internal inductances <math>L_i</math> of each FM, cFM or CSA approved apparatus in the loop.</td> </tr> <tr> <td><math>C_o</math></td> <td>equal or greater than</td> <td>The sum of the cable capacitance and the internal capacitance <math>C_i</math> of each FM, cFM or CSA approved apparatus in the loop.</td> </tr> </table> </li> </ol>	$U_o$	equal or less than	The lowest $U_i$ of the FM, cFM or CSA approved apparatus installed in the loop.	$I_o$	equal or less than	The lowest $I_i$ of the FM, cFM or CSA approved apparatus installed in the loop.	$P_o$	equal or less than	The lowest $P_i$ of the FM, cFM or CSA approved apparatus installed in the loop.	$L_o$	equal or greater than	The sum of the cable inductances and the internal inductances $L_i$ of each FM, cFM or CSA approved apparatus in the loop.	$C_o$	equal or greater than	The sum of the cable capacitance and the internal capacitance $C_i$ of each FM, cFM or CSA approved apparatus in the loop.
$U_o$	equal or less than	The lowest $U_i$ of the FM, cFM or CSA approved apparatus installed in the loop.																		
$I_o$	equal or less than	The lowest $I_i$ of the FM, cFM or CSA approved apparatus installed in the loop.																		
$P_o$	equal or less than	The lowest $P_i$ of the FM, cFM or CSA approved apparatus installed in the loop.																		
$L_o$	equal or greater than	The sum of the cable inductances and the internal inductances $L_i$ of each FM, cFM or CSA approved apparatus in the loop.																		
$C_o$	equal or greater than	The sum of the cable capacitance and the internal capacitance $C_i$ of each FM, cFM or CSA approved apparatus in the loop.																		
Iss.	Date	Modification	Ckd.	Appd.																
1	13.10 2010	New drawing																		
<p>Title FM &amp; cFM Intrinsically Safe Control Drawing for                  BA304E, BA307E &amp; 308E 4 DIGIT INDICATORS                  BA324E, 327E &amp; BA328E 5 DIGIT INDICATORS                  BA354E &amp; BA358E RATE TOTALISERS</p>																				
Drawn RC		Checked 		Scale -																
Drawing No. Sheet 3		C1300-72																		

File No 300-72s3.dwg 15.10.10

Iss.		Date		Modification		Ckd.		Appd.		<p>5. Simple Apparatus as defined in the National Electrical Code ANSI/NFPA 70, or for installations in Canada by the Canadian Electrical Code C22.2 OR:</p> <p>Ui equal or greater than The highest Uo of the FM, cFM or CSA approved apparatus powering the loop.</p> <p>li equal or greater than The highest lo of the FM, cFM or CSA approved apparatus powering the loop.</p> <p>Pi equal or greater than The highest Po of the FM, cFM or CSA approved apparatus powering the loop.</p> <p>Lo of the FM, cFM or CSA approved apparatus powering the loop equal or greater than The sum of the cable inductances and the internal inductances Li of each FM, cFM or CSA approved apparatus in the loop.</p> <p>Co of the FM, cFM or CSA approved apparatus powering the loop equal or greater than The sum of the cable capacitances and the internal capacitances Ci of each FM, cFM or CSA approved apparatus in the loop.</p> <p>6. Reset terminals RS1 and RS2 are only fitted to BA354E and BA358E Rate Totalisers. They may be connected to one single channel or one two channel associated protective barrier or galvanic isolator as defined in note 4. And / or to a single pole switch complying with requirements for simple apparatus as defined in the National Electrical Code ANSI/NFPA 70, or for installations in Canada by the Canadian Electrical Code C22.2.</p> <p>7. When installed in a hazardous (classified) location the BA304E and BA324E field mounting Indicators and the BA354 field mounting Rate Totaliser shall be fitted with cable glands / conduit hubs selected from the following table .</p> <p>Metallic glands and hubs must be grounded.</p> <table border="1" style="width:100%; border-collapse: collapse;"> <thead> <tr> <th style="width:20%;">Class</th> <th>Permitted gland or conduit hub</th> </tr> </thead> <tbody> <tr> <td>Class I</td> <td>Any metallic or plastic cable gland or conduit hub that provides the required environmental protection.</td> </tr> <tr> <td>Class II and III</td> <td> <b>Crouse – Hinds Myler hubs</b>                      ST-1 STA-1 SSTG-1 STG-1 STAG-1 MHUB-1 HUB 1  <b>O-Z / Gedrey Hubs</b>                      CHM-50DT CHMG-50DT  <b>REMKE hub</b>                      WH-1-G  <b>Killark Glands</b>                      CMCXAA050 MCR050 MCX050                 </td> </tr> </tbody> </table>	Class	Permitted gland or conduit hub	Class I	Any metallic or plastic cable gland or conduit hub that provides the required environmental protection.	Class II and III	<b>Crouse – Hinds Myler hubs</b> ST-1 STA-1 SSTG-1 STG-1 STAG-1 MHUB-1 HUB 1 <b>O-Z / Gedrey Hubs</b> CHM-50DT CHMG-50DT <b>REMKE hub</b> WH-1-G <b>Killark Glands</b> CMCXAA050 MCR050 MCX050	
Class	Permitted gland or conduit hub																
Class I	Any metallic or plastic cable gland or conduit hub that provides the required environmental protection.																
Class II and III	<b>Crouse – Hinds Myler hubs</b> ST-1 STA-1 SSTG-1 STG-1 STAG-1 MHUB-1 HUB 1 <b>O-Z / Gedrey Hubs</b> CHM-50DT CHMG-50DT <b>REMKE hub</b> WH-1-G <b>Killark Glands</b> CMCXAA050 MCR050 MCX050																
Iss.	1	Date	13.10 2010	Modification		Ckd.		Appd.		<p>Title FM &amp; cFM Intrinsically Safe Control Drawing for                      BA304E, BA307E &amp; 308E 4 DIGIT INDICATORS                      BA324E, 327E &amp; BA328E 5 DIGIT INDICATORS                      BA354E &amp; BA358E RATE TOTALISERS</p> <table style="width:100%;"> <tr> <td style="width:20%;">Drawn RC</td> <td style="width:20%;">Checked </td> <td style="width:20%;">Scale -</td> </tr> <tr> <td colspan="2">Drawing No. Sheet 4</td> <td style="font-size: 24px; font-weight: bold;">CI300-72</td> </tr> </table>	Drawn RC	Checked 	Scale -	Drawing No. Sheet 4		CI300-72	
Drawn RC	Checked 	Scale -															
Drawing No. Sheet 4		CI300-72															

File No 300-72s4.dwg 15.10.10



Iss.	Date	Modification	Ckd.	Appd.	<p>8. In addition to the supplied bonding plate, when 2 or 3 metallic glands or conduit hubs are fitted to a BA304E or BA324E Indicator or to a BA354E Rate Totaliser, all metallic glands or conduit hubs must be connected together and grounded.</p> <p>9. <b>CAUTION</b> The BA304E, BA307E, BA308E, BA324E, BA327E and the BA328E Indicators and the BA354E and the BA358C Rate Totaliser enclosures are manufactured from conducting plastic per Article 250 of the National Electrical Code.</p> <p>10. The BA304E, BA307E, BA308E, BA324E, BA327E and the BA328E Indicators and the BA354E and the BA358C Rate Totaliser shall be mounted where they are shielded from direct sunlight.</p> <p>11. When mounting the BA307E, BA308E, BA327E and the BA328E panel mounting Indicators and the BA358C panel mounting Rate Totaliser in an enclosure to maintain Type 4 front panel rating:</p> <p>Minimum panel thickness should be <span style="float: right;">2mm (0.08inches) Steel 3mm (0.12inches) Aluminium</span></p> <p>Outside panel finish should be smooth, free from particles, inclusions, runs or build-ups around cut-out.</p> <p>Panel cut-out for BA307E and BA327E should be: <span style="float: right;">90.0 x 43.5mm -0.0 +0.5mm (3.54 x 1.71 inches -0.00 +0.02)</span></p> <p>Two panel mounting clips are required and each should be tightened to between: <span style="float: right;">20 &amp; 22cNm (1.77 to 1.95inLb)</span></p> <p>Panel cut-out for BA308E, BA328E &amp; BA358E should be: <span style="float: right;">66.2 x 136.0mm-0.0 +0.5mm (2.60 x 5.35 inches -0.00 +0.02)</span></p> <p>Four panel mounting clips are required and each should be tightened to between: <span style="float: right;">20 &amp; 22cNm (1.77 to 1.95inLb)</span></p> <p>12. BA304E, BA307E, BA308E, BA324E, BA327E &amp; BA328E loop powered Indicators and BA354E &amp; BA358E loop powered Rate Totalisers.</p>
Iss.	Date	Modification	Ckd.	Appd.	<p>Title FM &amp; cFM Intrinsically Safe Control Drawing for BA304E, BA307E &amp; 308E 4 DIGIT INDICATORS BA324E, 327E &amp; BA328E 5 DIGIT INDICATORS BA354E &amp; BA358E RATE TOTALISERS</p> <p>Drawn RC Checked  Scale -</p> <p>Drawing No. CI300-72 Sheet 5</p>
1	13.10.2010				

File No 300-72s5.dwg 15.10.10











Iss.	Date	Modification	Ckd.	Appd.	<p><b>BEKA associates</b> Hitchin England company confidential, copyright reserved.</p>	<p><b>11. Safety parameters</b></p> <p>4/20mA input terminals 1, 2, 3 &amp; 4</p> <p> <math>U_i = 30V</math>  <math>I_i = 200mA</math>  <math>P_i = 0.85W</math>  <math>U_o = 0.7V</math>  <math>I_o = 1.3\mu A</math>  <math>P_o = 4.0\mu W</math> </p> <p> <math>C_i = 15nF</math>  <math>L_i = 0.01mH</math> </p> <p>Separately powered backlight terminals 12 &amp; 14.</p> <p> <math>U_i = 28V</math>  <math>I_i = 110mA</math>  <math>P_i = 0.77W</math>  <math>U_o =</math>  <math>I_o =</math>  <math>P_o =</math> </p> <p> <math>C_i = 15nF</math>  <math>L_i = 0.02mH</math> </p> <p>Reset terminals RS1 &amp; RS2 BA354E &amp; BA358E rate totaliser only.</p> <p> <math>U_i = 28V</math>  <math>I_i = 98mA</math>  <math>P_i = 0.65W</math> </p> <p> <math>C_i = 15nF</math>  <math>L_i = 0.01mH</math> </p>	<p>4/20mA input terminals 1, 2, 3, 4, 12 &amp; 13 &amp; loop powered backlight.</p> <p> <math>U_i = 30V</math>  <math>I_i = 200mA</math>  <math>P_i = 0.85W</math>  <math>U_o = 0.7V</math>  <math>I_o = 1.3\mu A</math>  <math>P_o = 4.0\mu W</math> </p> <p> <math>C_i = 30nF</math>  <math>L_i = 0.01mH</math> </p> <p>Alarm terminals 8, 9, 10 and 11</p> <p> <math>U_i = 30V</math>  <math>I_i = 200mA</math>  <math>P_i = 0.85W</math>  <math>U_o = 0.7V</math>  <math>I_o = 1.3\mu A</math>  <math>P_o = 4.0\mu W</math> </p> <p> <math>C_i = 15nF</math>  <math>L_i = 0.01mH</math> </p>
Iss.	Date	Modification	Ckd.	Appd.	<p><b>12. BA304E, BA307E, BA308E, BA324E, BA327E &amp; BA328E loop powered Indicators and BA354E &amp; BA358E loop powered Rate Totalisers.</b></p>		
Iss.	Date	Modification	Ckd.	Appd.	<p>Title FM &amp; cFM Nonincendive Control Drawing for BA304E, BA307E &amp; 308E 4 DIGIT INDICATORS BA324E, 327E &amp; BA328E 5 DIGIT INDICATORS BA354E &amp; BA358E RATE TOTALISERS</p>		
Date		Drawn		Checked		Scale	
15.10.2010		RC				-	
1		Drawing No.		CI300-73			
		Sheet 5					

File No 300-73s5.dwg 19.10.10

# Appendix B

## EC Declaration of Conformity



## Appendix B EC Declaration of Conformity



# Declaration of Conformity

This certificate is issued for electrical apparatus BA304E & BA324E

**Description**

BA304E 4 digit and BA324E 5 digit intrinsically safe field mounting 4/20mA loop powered indicators

**Manufactured by**

BEKA associates Ltd, Old Charlton Road, Hitchin, Herts. UK. SG5 2DA

**Council Directives this equipment complies with:**

**94/9/EC (ATEX Directive) until 19<sup>th</sup> April 2016 & valid for 2014/34/EU (ATEX Directive) from 20<sup>th</sup> April 2016**

Relating to equipment and protective systems intended for use in potentially explosive atmospheres.

**Provisions of the Directive fulfilled by the equipment:**

Group II Category 1G Ex ia IIC T5 Ga Ta -40°C to +70°C

Group II Category 1D Ex ia IIIC T80°C Da IP66 Ta -40°C to +70°C

**Notified Body for EC-Type Examination and production**

Intertek Testing & Certification Ltd 0359 Leatherhead UK

**EC-Type Examination Certificate**

ITS11ATEX27253X issue 1 15/04/2011; issue 2 12<sup>th</sup> August 2015.

**Standards used:**

EN 60079-0:2012/A11:2013; EN 60079-11:2012 except in respect of those requirements referred to at item 16 of the Schedule.

**2004/108/EC (EMC Directive) until 19<sup>th</sup> April 2016 & valid for 2014/30/EU (EMC Directive) from 20<sup>th</sup> April 2016**

**Standards used:**

BS EN 61326-1:2013



mark first affixed in 2011

Authorised Signatory:

Ben Brough  
Managing Director

Issue 1	1 <sup>st</sup> Nov 2011
Issue 2	18 <sup>th</sup> Oct 2014
Issue 3	25 <sup>th</sup> Feb 2015
Issue 4	1 <sup>st</sup> Jul 2015
Issue 5	12 <sup>th</sup> Oct 2015
Issue 6	5 <sup>th</sup> April 2016



**BEKA associates Ltd. Old Charlton Road, Hitchin, SG5 2DA UK**  
Telephone +44 (0) 1462 438301 Fax +44 (0) 1462 453971  
e-mail [sales@beka.co.uk](mailto:sales@beka.co.uk) [www.beka.co.uk](http://www.beka.co.uk)

# Appendix C

## Quality, Recycling & Warranty Information

## Appendix C Quality, Recycling & Warranty Information

### C.1 Pressure Equipment Directive (PED) 97/23/EC

The above Directive has been implemented in United Kingdom Law by the Pressure Equipment Regulations 1999.

The Regulations require that all pressure equipment and assemblies within the scope of the Pressure Equipment Directive must be safe when placed on the market or put into service.

Michell Instruments' products have been assessed and, as referenced against the Classification Charts detailed in Annex II of the Directive, do not fall into the requirements for CE marking compliance with the Pressure Equipment Directive.

Article 3, paragraph 3 states that any product containing a pressurized fluid that does not qualify for compliance should, nevertheless, be constructed with Sound Engineering Practice (SEP).

Michell Instruments attests here that its products have been designed, manufactured & tested to assure safe operation, and in accordance with Sound Engineering Practices.

### C.2 Recycling Policy



Michell Instruments is concerned with the protection of the environment. It is our commitment to reduce and eliminate from our operations, wherever possible, the use of substances which may be harmful to the environment. Similarly, we are increasingly using recyclable and/or recycled material in our business and products wherever it is practical to do so.

To protect natural resources and to promote material reuse, please separate batteries from other types of waste and recycle responsibly. If batteries are not properly disposed of, these substances can cause harm to human health and the environment.

The product that you have purchased may contain recyclable and/or recycled parts and we will be happy to provide you with information on these components if required. For further information please see the following sections.

### C.3 WEEE Compliance

#### Directive 2012/19/EU 4 July 2012 on Waste Electronic and Electrical Equipment (WEEE)

The Waste Electronic and Electrical Equipment (WEEE) Directive places rules upon European manufacturers of electrical and electronic equipment. The directives' aim is to reduce the impact that electronic devices have on the environment.

Michell Instruments is in full compliance with the WEEE Directive and is registered with an approved recycler (Registration No. WEE/JB0235YW) and treats the requirement of the directive and the protection of the environment with the utmost importance. All Michell Instruments' products are appropriately marked indicating their requirement for recycling.

It may be required to return certain instruments for treatment at the end of their working life.

Feb 2013

## C.4 RoHS2 Compliance

### Directive 2011/65/EU of the European Parliament and of the Council of 8 June 2011

The Restriction of Hazardous Substances (RoHS) Directive places rules upon European manufacturers of electrical and electronic equipment. The directives' aim is to reduce the impact that electronic devices have on the environment.

According to the EC Directive 2002/95/EC, Michell Instruments' products qualify as Category 9, Control and Monitoring Equipment. Under the 2002/95/EC Directive, Category 9 products are exempt from compliance with the Directive.

However, the careful design of all Michell Instruments' products takes into consideration the requirements of the Directive and, wherever possible, compliance is achieved. All future products will be developed entirely using compliant materials. Furthermore, Michell Instruments is taking active steps to remove non-compliant materials and components from existing products wherever these may occur. Presently, none of the non-compliant materials are known to occur in Michell Instruments' products.

The new Directive 2011/65/EU (RoHS2) entered into force on 21 July 2011 and required all Member States to transpose the provisions into their respective national laws by 2 January 2013.

Under the provisions of the RoHS2 EU Directive 2011/65/EU (Article 3, [24]) defines 'Control and Monitoring Equipment' specifically as 'monitoring and control instruments designed exclusively for industrial or professional use'.

RoHS2 EU Directive 2011/65/EU states the closing date for compliance of any Control and Monitoring Equipment product sold into the EU market place as 22nd July 2017.

However, the careful design policy of all Michell Instruments' products continues to attain compliance in the shortest practical timescales and strives to ensure that less than 0.1% of total mass per product, of all non-compliant materials, appear within them. Michell Instruments continues to monitor suppliers and material sources to ensure that compliance of goods provided is maintained.

January 2013

## C.5 Warranty

Unless otherwise agreed, the Supplier warrants that, as from the date of delivery for a period of 12 months, the goods and all their component parts, where applicable, are free from any defects in design, workmanship, construction or materials.

The Supplier warrants that the services undertaken shall be performed using reasonable skill and care, and be of a quality conforming to generally accepted industry standards and practices.

Except as expressly stated, all warranties whether express or implied, by operation of law or otherwise, are hereby excluded in relation to the goods and services to be provided by the Supplier.

All warranty services are provided on a return to base basis. Any transportation costs for the return of a warranty claim shall reside with the Customer.

## C.6 REACH Compliance

Regulation (EC) No. 1907/2006

Registration, Evaluation, Authorisation and Restriction of Chemicals (REACH)

Michell Instruments is a manufacturer of moisture measurement and gas analysis instrumentation and is a 'downstream' user of chemicals, as described by the EU Council Directive 76/769/EEC. The products we supply are not raw chemical products (goods).

Under normal and reasonably foreseeable circumstances of application, the goods supplied to you shall not contain or release any prohibited chemicals. No listed SVHC (Substances of Very High Concern) appear within products manufactured by Michell Instruments. Therefore the 0.1% mass per product, or total usage of 1 tonne/year, will never be exceeded. For these reasons we are neither required by obligation for registration nor for the creation of material safety data sheets (MSDS) for our products.

Our continued review of the SVHC Candidate List and latest additions is to ensure we remain compliant.

Michell Instruments maintains a hazardous material register in which MSDS data sheets are collated, and we will check that our suppliers will comply to REACH requirements for all materials and substances we use in the processes of our manufacturing.

In the unlikely event that any chemicals of concern appear in our products in quantities greater than 0.1% of total mass per product we will immediately inform you by correspondence according to the REACH Article 33 requirements. Our current appraisal is, however, that we do not expect or foresee such an incidence.

January 2013

## C.7 Calibration Facilities

Michell Instruments' calibration facilities are among the most sophisticated in the world and have been recognized for their excellence.

Traceability to the National Physical Laboratory (NPL) UK is achieved through our UKAS Accreditation (Number 0179). This covers dew point over the range -90 to +90°C (-130 to +194°F) and also Relative Humidity.

Dew-point calibrations are also traceable to the National Institute for Standards & Technology (NIST) USA over the range -75 to +20°C (-103 to +68°F).

**NOTE: Standard traceable calibration certificates for instruments and sensors are not issued under our UKAS accreditation.**

### C.8 Return Policy

If a Michell Instruments' product malfunctions within the warranty period, the following procedure must be completed:

1. Notify a Michell Instruments' distributor, giving full details of the problem, the model variant and the serial number of the product.
2. If the nature of the problem indicates the need for factory service then the instrument should be returned to Michell Instruments, carriage prepaid, preferably in the original packaging, with a full description of the fault and the customer contact information.
3. Upon receipt, Michell Instruments will evaluate the product to determine the cause of the malfunction. Then, one of the following courses of action will be taken:
  - If the fault is covered under the terms of the warranty, the instrument will be repaired at no cost to the owner and returned.
  - If Michell Instruments determines that the fault is not covered under the terms of the warranty, or if the warranty has expired, an estimate for the cost of the repairs, at standard rates, will be provided. Upon receipt of the owner's approval to proceed, the product will be repaired and returned.

### C.9 Manufacturing Quality

Michell Instruments is registered with the British Standards Institute for Quality Assurance to:

BS EN ISO 9001: 2008

Rigorous procedures are performed at every stage of production to ensure that the materials of construction, manufacturing, calibration and final test procedures meet the requirements laid down by our BSI approved Quality System.

Please contact Michell Instruments ([www.michell.com](http://www.michell.com)) if the product does not arrive in perfect working order.

# Appendix D

## Return Document & Decontamination Declaration

## Appendix D Return Document &amp; Decontamination Declaration

## Decontamination Certificate

**IMPORTANT NOTE:** Please complete this form prior to this instrument, or any components, leaving your site and being returned to us, or, where applicable, prior to any work being carried out by a Michell engineer at your site.

Instrument			Serial Number	
Warranty Repair?	YES	NO	Original PO #	
Company Name			Contact Name	
Address				
Telephone #			E-mail address	
Reason for Return /Description of Fault:				
Has this equipment been exposed (internally or externally) to any of the following? Please circle (YES/NO) as applicable and provide details below				
Biohazards	YES		NO	
Biological agents	YES		NO	
Hazardous chemicals	YES		NO	
Radioactive substances	YES		NO	
Other hazards	YES		NO	
Please provide details of any hazardous materials used with this equipment as indicated above (use continuation sheet if necessary)				
Your method of cleaning/decontamination				
Has the equipment been cleaned and decontaminated?	YES		NOT NECESSARY	
Michell Instruments will not accept instruments that have been exposed to toxins, radio-activity or bio-hazardous materials. For most applications involving solvents, acidic, basic, flammable or toxic gases a simple purge with dry gas (dew point <-30°C) over 24 hours should be sufficient to decontaminate the unit prior to return. <b>Work will not be carried out on any unit that does not have a completed decontamination declaration.</b>				
<b>Decontamination Declaration</b>				
I declare that the information above is true and complete to the best of my knowledge, and it is safe for Michell personnel to service or repair the returned instrument.				
Name (Print)			Position	
Signature			Date	



## NOTES:



<http://www.michell.com>