

Operating Instructions

Process pressure transmitter CPT-2x

GB

Foundation Fieldbus
Ceramic sensor



Process pressure transmitter CPT-2x



Contents

1	About this document	4
1.1	Function	4
1.2	Target group	4
1.3	Symbols used.....	4
2	For your safety	5
2.1	Authorised personnel	5
2.2	Appropriate use.....	5
2.3	Warning about incorrect use.....	5
2.4	General safety instructions	5
2.5	EU conformity.....	6
2.6	Permissible process conditions	6
2.7	NAMUR recommendations	6
2.8	Installation and operation in the USA and Canada	6
3	Product description	7
3.1	Configuration.....	7
3.2	Principle of operation.....	8
3.3	Packaging, transport and storage.....	12
4	Mounting	14
4.1	General instructions	14
4.2	Ventilation and pressure compensation.....	15
4.3	Process pressure measurement.....	17
4.4	Level measurement.....	19
4.5	External housing	20
5	Connecting to the bus system	21
5.1	Preparing the connection	21
5.2	Connecting.....	22
5.3	Single chamber housing.....	23
5.4	Double chamber housing	23
5.5	Double chamber housing Ex d	25
5.6	Housing IP 66/IP 68 (1 bar)	25
5.7	External housing with version IP 68 (25 bar).....	26
5.8	Switch-on phase.....	27
6	Set up with the display and adjustment module	29
6.1	Insert display and adjustment module	29
6.2	Adjustment system	30
6.3	Measured value indication.....	31
6.4	Parameter adjustment - Quick setup	32
6.5	Parameter adjustment - Extended adjustment.....	32
6.6	Saving the parameterisation data.....	43
7	Setup with PACTware	44
7.1	Parameter adjustment	44
7.2	Saving the parameterisation data.....	44
8	Diagnosis, asset management and service	45
8.1	Maintenance	45
8.2	Cleaning - hygienic connection with compression nut	45

8.3	Diagnosis memory	46
8.4	Asset Management function.....	47
8.5	Rectify faults.....	50
8.6	Exchange process module on version IP 68 (25 bar)	50
8.7	Instrument repair	51
9	Dismount.....	52
9.1	Dismounting steps.....	52
9.2	Disposal	52
10	Supplement	53
10.1	Technical data	53
10.2	Supplementary information Foundation Fieldbus	65
10.3	Calculation of the total deviation.....	69
10.4	Practical example	70
10.5	Dimensions	73
10.6	Trademark	84

Safety instructions for Ex areas



Take note of the Ex specific safety instructions for Ex applications. These instructions are attached as documents to each instrument with Ex approval and are part of the operating instructions.

Editing status: 2019-03-11

1 About this document

1.1 Function

This operating instructions provides all the information you need for mounting, connection and setup as well as important instructions for maintenance, fault rectification, the exchange of parts and the safety of the user. Please read this information before putting the instrument into operation and keep this manual accessible in the immediate vicinity of the device.

1.2 Target group

This operating instructions manual is directed to trained personnel. The contents of this manual must be made available to the qualified personnel and implemented.

1.3 Symbols used



Information, tip, note

This symbol indicates helpful additional information.



Caution: If this warning is ignored, faults or malfunctions can result.



Warning: If this warning is ignored, injury to persons and/or serious damage to the instrument can result.



Danger: If this warning is ignored, serious injury to persons and/or destruction of the instrument can result.



Ex applications

This symbol indicates special instructions for Ex applications.



List

The dot set in front indicates a list with no implied sequence.



Action

This arrow indicates a single action.



Sequence of actions

Numbers set in front indicate successive steps in a procedure.



Battery disposal

This symbol indicates special information about the disposal of batteries and accumulators.

2 For your safety

2.1 Authorised personnel

All operations described in this documentation must be carried out only by trained, qualified personnel authorised by the plant operator. During work on and with the device, the required personal protective equipment must always be worn.

2.2 Appropriate use

The CPT-2x is a pressure transmitter for process pressure and hydrostatic level measurement.

You can find detailed information about the area of application in chapter "*Product description*".

Operational reliability is ensured only if the instrument is properly used according to the specifications in the operating instructions manual as well as possible supplementary instructions.

2.3 Warning about incorrect use

Inappropriate or incorrect use of this product can give rise to application-specific hazards, e.g. vessel overfill through incorrect mounting or adjustment. Damage to property and persons or environmental contamination can result. Also, the protective characteristics of the instrument can be impaired.

2.4 General safety instructions

This is a state-of-the-art instrument complying with all prevailing regulations and directives. The instrument must only be operated in a technically flawless and reliable condition. The operator is responsible for the trouble-free operation of the instrument. When measuring aggressive or corrosive media that can cause a dangerous situation if the instrument malfunctions, the operator has to implement suitable measures to make sure the instrument is functioning properly.

During the entire duration of use, the user is obliged to determine the compliance of the necessary occupational safety measures with the current valid rules and regulations and also take note of new regulations.

The safety instructions in this operating instructions manual, the national installation standards as well as the valid safety regulations and accident prevention rules must be observed by the user.

For safety and warranty reasons, any invasive work on the device beyond that described in the operating instructions manual may be carried out only by personnel authorised by the manufacturer. Arbitrary conversions or modifications are explicitly forbidden. For safety reasons, only the accessory specified by the manufacturer must be used.

To avoid any danger, the safety approval markings and safety tips on the device must also be observed and their meaning read in this operating instructions manual.

2.5 EU conformity

The device fulfils the legal requirements of the applicable EU directives. By affixing the CE marking, we confirm the conformity of the instrument with these directives.

2.6 Permissible process conditions

For safety reasons, the instrument must only be operated within the permissible process conditions. You can find detailed information on the process conditions in chapter "*Technical data*" as well as on the type label.

The permissible process pressure range is specified by "MWP" (Maximum Working Pressure) on the type label, see chapter "*Structure*". The MWP takes the element of the measuring cell and processing fitting combination with the weakest pressure into consideration and may be applied permanently. The specification refers to a reference temperature of +20 °C (+68 °F). It also applies when a measuring cell with a higher measuring range than the permissible pressure range of the process fitting is installed order-related.

In order to prevent damage to the device, the test pressure may only exceed the specified MWP briefly by 1.5 times at reference temperature. The pressure stage of the process fitting as well as the overload resistance of the measuring cell are taken into consideration here (see chapter "*Technical Data*").

In addition, a temperature derating of the process fitting, e. g. with flanges, can limit the permissible process pressure range according to the respective standard.

2.7 NAMUR recommendations

NAMUR is the automation technology user association in the process industry in Germany. The published NAMUR recommendations are accepted as the standard in field instrumentation.

The device fulfils the requirements of the following NAMUR recommendations:

- NE 21 – Electromagnetic compatibility of equipment
- NE 53 – Compatibility of field devices and display/adjustment components
- NE 107 – Self-monitoring and diagnosis of field devices

For further information see www.namur.de.

2.8 Installation and operation in the USA and Canada

This information is only valid for USA and Canada. Hence the following text is only available in the English language.

Installations in the US shall comply with the relevant requirements of the National Electrical Code (ANSI/NFPA 70).

Installations in Canada shall comply with the relevant requirements of the Canadian Electrical Code.

3 Product description

3.1 Configuration

Scope of delivery

The scope of delivery encompasses:

- Instrument CPT-2x
- Documentation
 - Operating instructions CPT-2x
 - Characteristics test certificate
 - Instructions for optional instrument features
 - Ex-specific "*Safety instructions*" (with Ex versions)
 - If necessary, further certificates



Note:

Optional instrument features are also described in this operating instructions manual. The respective scope of delivery results from the order specification.

Scope of this operating instructions

This operating instructions manual applies to the following instrument versions:

- Hardware from 1.0.0
- Software version from 1.2.1



Note:

You can find the hardware and software version of the instrument as follows:

- On the type plate of the electronics module
- In the adjustment menu under "*Info*"

Type label

The type label contains the most important data for identification and use of the instrument:



Fig. 1: Layout of the type label (example)

- 1 Instrument type
- 2 Field for approvals
- 3 Signal output and voltage supply
- 4 Technical data
- 5 Product code
- 6 Order number
- 7 Serial number of the instrument
- 8 Symbol of the device protection class
- 9 ID numbers, instrument documentation
- 10 Reminder to observe the instrument documentation

3.2 Principle of operation

Application area

CPT-2x is suitable for applications in virtually all industries. It is used for the measurement of the following pressure types.

- Gauge pressure
- Absolute pressure
- Vacuum

Measured products

Measured products are gases, vapours and liquids.

Depending on the process fitting and measurement setup, measured products can be also viscous or contain abrasive substances.

Measured variables

The CPT-2x is suitable for the measurement of the following process variables:

- Process pressure
- Level

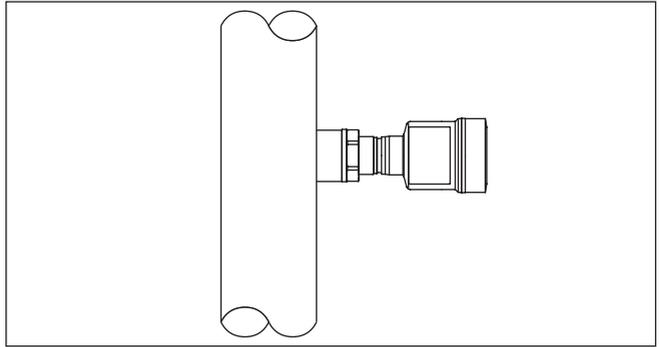

Fig. 2: Process pressure measurement CPT-2x

Measuring system pressure

Sensor element is the measuring cell with robust ceramic diaphragm. The process pressure deflects the ceramic diaphragm and causes a capacitance change in the measuring cell. This capacitance change is converted into an electrical signal and output as measured value via the output signal.

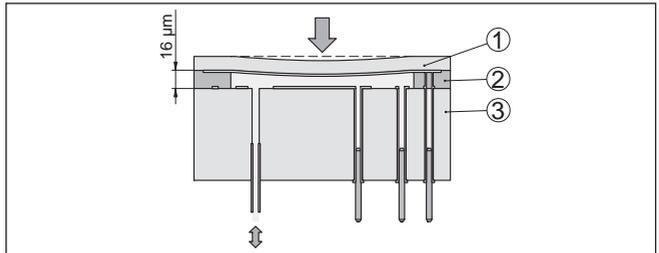

Fig. 3: Configuration of the ceramic measuring cell

- 1 Process diaphragm
- 2 Glass joint
- 3 Base element

The measuring cell is available in two sizes: \varnothing 28 mm and \varnothing 17.5 mm.

Measuring system temperature

Temperature sensors in the ceramic diaphragm and on the ceramic body of the \varnothing 28 mm measuring cell or on the electronics of the \varnothing 17.5 mm measuring cell detect the current process temperature. The temperature value is output via:

- The display and adjustment module
- The current output or the digital signal output

Extreme process temperature jumps are also immediately detected by the \varnothing 28 mm measuring cell. The values in the ceramic diaphragm are compared with that on the ceramic base body.

Within only a few measuring cycles the intelligent sensor electronics compensates unavoidable measurement deviations due to temperature shocks. Such shocks cause (depending on the set damping) only slight, brief changes to the output signal.

Pressure types

The measuring cell design depends on the selected pressure type.

Relative pressure: the measuring cell is open to the atmosphere. The ambient pressure is detected in the measuring cell and compensated. It thus has no influence on the measured value.

Absolute pressure: the measuring cell is evacuated and encapsulated. The ambient pressure is not compensated and does hence influence the measured value.

Seal concepts

The following presentations show examples for the installation of the ceramic measuring cell into the process fitting and the different seal concepts.

Recessed installation

The recessed installation is particularly suitable for applications with gases, vapours and clear liquids. The measuring cell seal is positioned laterally as well as in addition in front.

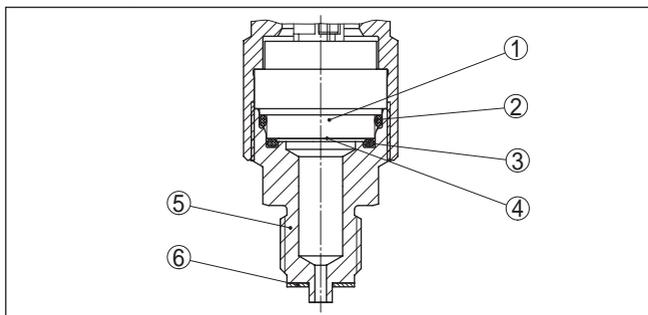

Fig. 4: Recessed installation of the measuring cell (example: manometer connection G $\frac{1}{2}$)

- 1 Measuring cell
- 2 Seal for the measuring cell
- 3 Additional, front seal for measuring cell
- 4 Diaphragm
- 5 Process fitting
- 6 Seal for the process fitting

Front-flush mounting with single seal

The front-flush installation is particularly suitable for applications with viscous and abrasive media and in case of buildup. The measuring cell seal is positioned laterally.

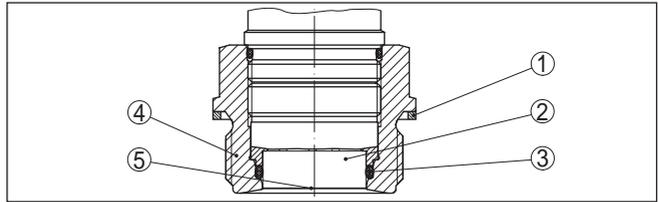

Fig. 5: Front-flush installation of the measuring cell (example: thread G1½)

- 1 Seal for the process fitting
- 2 Measuring cell
- 3 Seal for the measuring cell
- 4 Process fitting
- 5 Diaphragm

Completely front-flush mounting with single seal

The completely front-flush mounting is particularly suitable for applications in the paper industry. The diaphragm is in the pulp flow, is hence cleaned and protected against buildup.

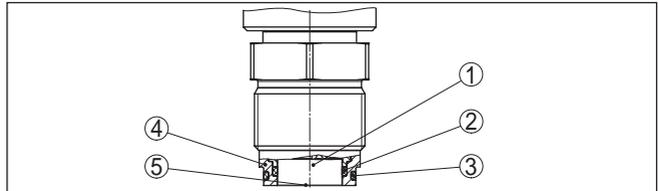

Fig. 6: Front-flush installation of the measuring cell (example: M30 x 1.5)

- 1 Measuring cell
- 2 Seal for the measuring cell
- 3 Seal for the process fitting
- 4 Process fitting
- 5 Diaphragm

Front-flush mounting with double seal

The front-flush installation is particularly suitable for applications with viscous media. The additional, front sealing protects the glass joint of the measuring cell against chemical attack and the measuring cell electronics against diffusion of aggressive gases from the process.

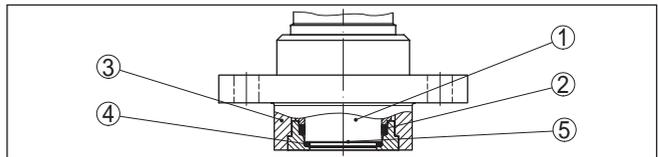

Fig. 7: Front-flush installation of the measuring cell with double seal (example: flange connection with extension)

- 1 Measuring cell
- 2 Seal for the measuring cell
- 3 Process fitting
- 4 Additional, front seal for measuring cell
- 5 Diaphragm

Installation in hygienic fitting

The front-flush, hygienic installation of the measuring cell is particularly suitable for food applications. The sealings are installed gap-free. The form seal of the measuring cell protects also the glass joint.

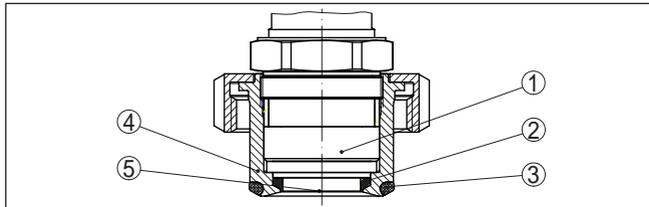

Fig. 8: Hygienic installation of the measuring cell (example: hygienic fitting with compression nut)

- 1 Measuring cell
- 2 Form seal for the measuring cell
- 3 Gap-free seal for process fitting
- 4 Process fitting
- 5 Diaphragm

Installation in hygienic fitting acc. to 3-A

The front-flush, hygienic installation of the measuring cell acc. to 3-A is particularly suitable for food applications. The sealings are installed gap-free. The additional front sealing for the measuring cell protects also the glass joint. A hole in the process fitting is used for leakage detection.

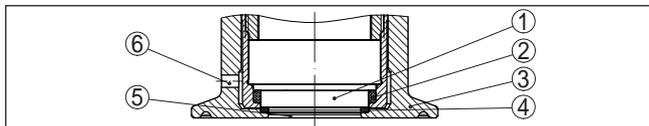

Fig. 9: Hygienic installation of the measuring cell acc. to 3-A (example: Clamp connection)

- 1 Measuring cell
- 2 Seal for the measuring cell
- 3 Process fitting
- 4 Additional, front seal for measuring cell
- 5 Diaphragm
- 6 Hole for leakage detection

3.3 Packaging, transport and storage

Packaging

Your instrument was protected by packaging during transport. Its capacity to handle normal loads during transport is assured by a test based on ISO 4180.

The packaging of standard instruments consists of environment-friendly, recyclable cardboard. For special versions, PE foam or PE foil is also used. Dispose of the packaging material via specialised recycling companies.

Transport

Transport must be carried out in due consideration of the notes on the transport packaging. Nonobservance of these instructions can cause damage to the device.

Transport inspection	The delivery must be checked for completeness and possible transit damage immediately at receipt. Ascertained transit damage or concealed defects must be appropriately dealt with.
Storage	<p>Up to the time of installation, the packages must be left closed and stored according to the orientation and storage markings on the outside.</p> <p>Unless otherwise indicated, the packages must be stored only under the following conditions:</p> <ul style="list-style-type: none">● Not in the open● Dry and dust free● Not exposed to corrosive media● Protected against solar radiation● Avoiding mechanical shock and vibration
Storage and transport temperature	<ul style="list-style-type: none">● Storage and transport temperature see chapter "<i>Supplement - Technical data - Ambient conditions</i>"● Relative humidity 20 ... 85 %
Lifting and carrying	With instrument weights of more than 18 kg (39.68 lbs) suitable and approved equipment must be used for lifting and carrying.

4 Mounting

4.1 General instructions

Process conditions

Make sure before mounting that all parts of the instrument exposed to the process are suitable for the existing process conditions.

These are mainly:

- Active measuring component
- Process fitting
- Process seal

Process conditions in particular are:

- Process pressure
- Process temperature
- Chemical properties of the medium
- Abrasion and mechanical influences

You can find detailed information on the process conditions in chapter "*Technical data*" as well as on the type label.

Protection against moisture

Protect your instrument against moisture ingress through the following measures:

- Use a suitable connection cable (see chapter "*Connecting to power supply*")
- Tighten the cable gland or plug connector
- When mounting horizontally, turn the housing so that the cable gland or plug connector point downward
- Lead the connection cable downward in front of the cable entry or plug connector

This applies mainly to outdoor installations, in areas where high humidity is expected (e.g. through cleaning processes) and on cooled or heated vessels.

To maintain the housing protection, make sure that the housing lid is closed during operation and locked, if necessary.

Make sure that the degree of contamination specified in chapter "*Technical data*" meets the existing ambient conditions.

Screwing in

On devices with a threaded fitting, the hexagon on the process fitting must be tightened with a suitable wrench.

See chapter "*Dimensions*" for wrench size.



Warning:

The housing or the electrical connection may not be used for screwing in! Tightening can cause damage, e. g. to the rotation mechanism of the housing.

Vibrations

If there is strong vibration at the mounting location, the instrument version with external housing should be used. See chapter "*External housing*".

Process pressure range - Mounting accessory

The permissible process pressure range is stated on the type label. The instrument should only be operated with these pressures if the mounting accessory used also fulfils these values. This should be ensured by suitable flanges, welded sockets, tension rings with Clamp connections, sealings, etc.

Temperature limits

Higher process temperatures often mean also higher ambient temperatures. Make sure that the upper temperature limits stated in chapter "*Technical data*" for the environment of the electronics housing and connection cable are not exceeded.

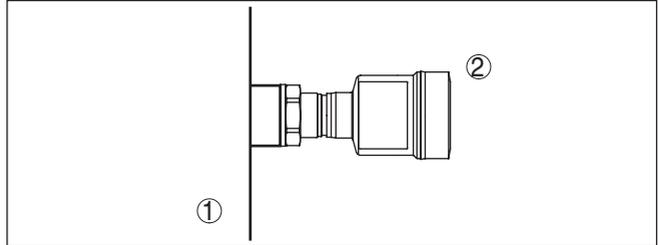

Fig. 10: Temperature ranges

- 1 Process temperature
- 2 Ambient temperature

4.2 Ventilation and pressure compensation

Filter element - Function

The filter element in the electronics housing has the following functions:

- Ventilation of the electronics housing
- Atmospheric pressure compensation (with relative pressure measuring ranges)



Caution:

The filter element causes a time-delayed pressure compensation. When quickly opening/closing the housing cover, the measured value can change for approx. 5 s by up to 15 mbar.

For an effective ventilation, the filter element must be always free from buildup. In case of horizontal mounting, turn the housing so that the filter element points downward after the instrument is installed. This provides better protection against buildup.



Caution:

Do not use a high-pressure cleaner. The filter element could be damaged, which would allow moisture into the housing.

The following paragraphs describe how the filter element is arranged in the different instrument versions.

Filter element - Position

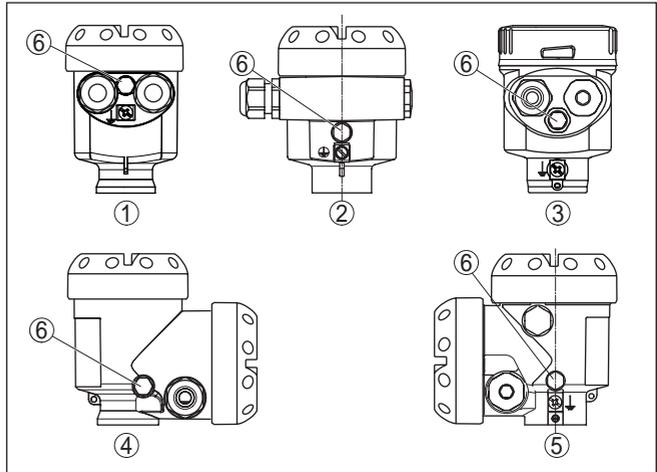

Fig. 11: Position of the filter element

- 1 Plastic, stainless steel single chamber (precision casting)
- 2 Aluminium - single chamber
- 3 Stainless steel single chamber (electropolished)
- 4 Plastic double chamber
- 5 Aluminium - double chamber
- 6 Filter element

With the following instruments a blind plug is installed instead of the filter element:

- Instruments in protection IP 66/IP 68 (1 bar) - ventilation via capillaries in non-detachable cable
- Instruments with absolute pressure

Filter element - Position Ex-d version

→ Turn the metal ring in such a way that the filter element points downward after installation of the instrument. This provides better protection against buildup.

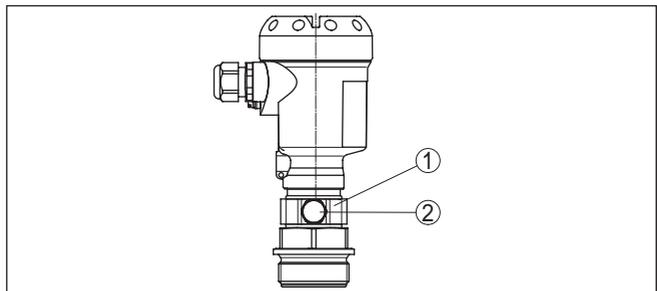

Fig. 12: Position of the filter element - Ex-d version

- 1 Rotatable metal ring
- 2 Filter element

Instruments with absolute pressure have a blind plug mounted instead of the filter element.

Filter element - Position Second Line of Defense

The Second Line of Defense (SLOD) is a second level of the process separation in form of a gas-tight leadthrough in the housing neck, preventing products from penetrating into the housing.

With these instruments, the process assembly is completely encapsulated. An absolute pressure measuring cell is used so that no ventilation is required.

With relative pressure measuring ranges, the ambient pressure is detected and compensated by a reference sensor in the electronics.

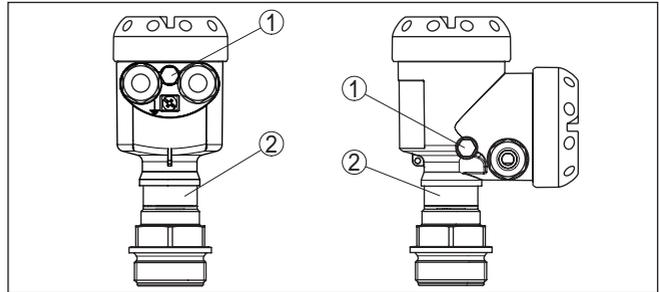

Fig. 13: Position of the filter element - gastight leadthrough

- 1 Filter element
- 2 Gas-tight leadthrough

Filter element - Position IP 69K version

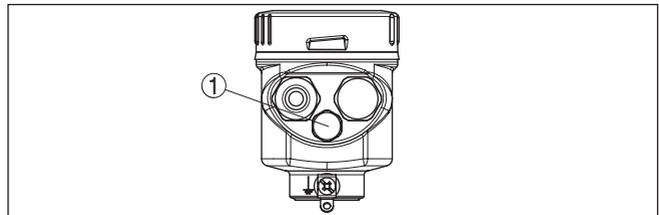

Fig. 14: Position of the filter element - IP 69K version

- 1 Filter element

Instruments with absolute pressure have a blind plug mounted instead of the filter element.

4.3 Process pressure measurement

Keep the following in mind when setting up the measuring system:

- Mount the instrument above the measuring point

Possible condensation can then drain off into the process line.

Measurement setup in gases

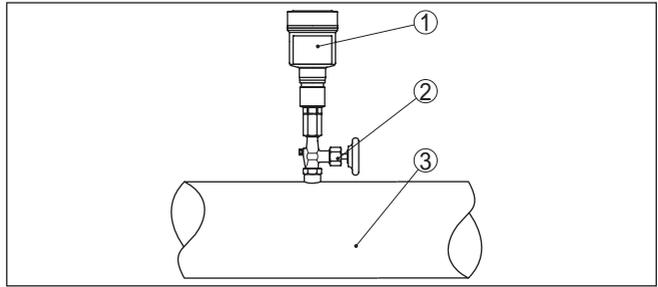

Fig. 15: Measurement setup for process pressure measurement of gases in pipelines

- 1 CPT-2x
- 2 Blocking valve
- 3 Pipeline

Measurement setup in vapours

Keep the following in mind when setting up the measuring system:

- Connect via a siphon
- Do not insulate the siphon
- Fill the siphon with water before setup

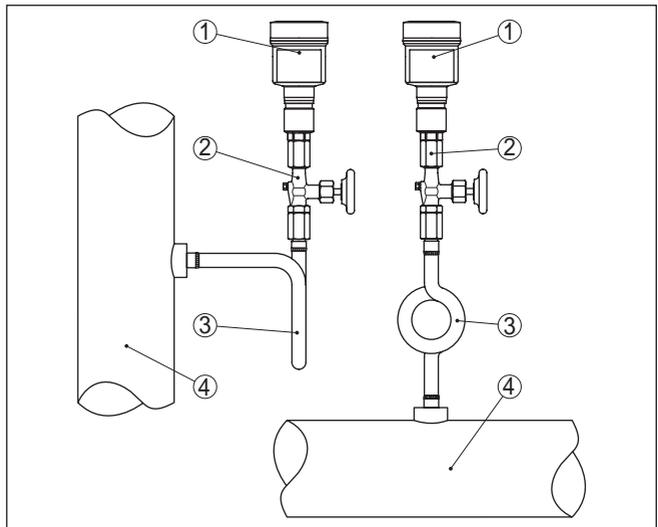

Fig. 16: Measurement setup with process pressure measurement of gases in pipelines

- 1 CPT-2x
- 2 Blocking valve
- 3 Siphon in U or circular form
- 4 Pipeline

A protective accumulation of water is formed through condensation in the pipe bends. Even in applications with hot steam, a medium temperature < 100 °C on the transmitter is ensured.

Measurement setup in liquids

Keep the following in mind when setting up the measuring system:

- Mount the instrument below the measuring point

The effective pressure line is always filled with liquid and gas bubbles can bubble up to the process line.

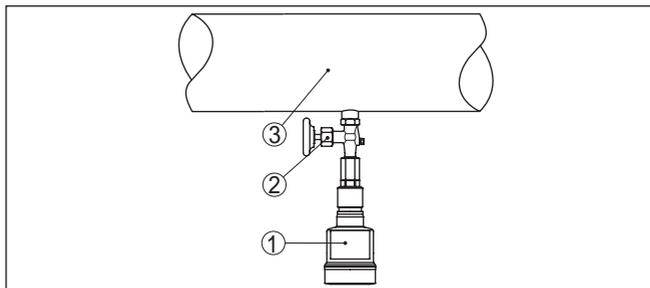

Fig. 17: Measurement setup for process pressure measurement of liquids in pipelines

- 1 CPT-2x
- 2 Blocking valve
- 3 Pipeline

4.4 Level measurement

Measurement setup

Keep the following in mind when setting up the measuring system:

- Mount the instrument below the min. level
- Do not mount the instrument close to the filling stream or emptying area
- Mount the instrument so that it is protected against pressure shocks from the stirrer

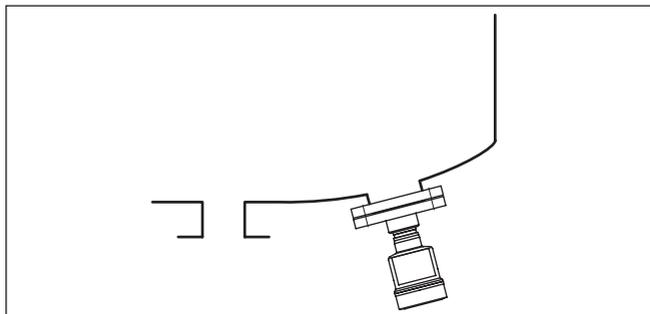

Fig. 18: Measurement setup for level measurement

4.5 External housing

Configuration

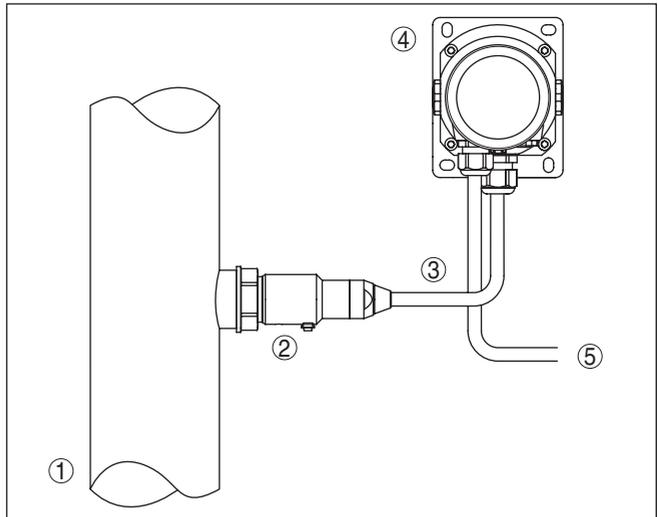

Fig. 19: Configuration, process module, external housing

- 1 Pipeline
- 2 Process module
- 3 Connection cable process assembly - External housing
- 4 External housing
- 5 Signal cable

5 Connecting to the bus system

5.1 Preparing the connection

Safety instructions

Always keep in mind the following safety instructions:

- Carry out electrical connection by trained, qualified personnel authorised by the plant operator
- If overvoltage surges are expected, overvoltage arresters should be installed



Warning:

Connect only in the complete absence of line voltage.

Voltage supply

The instrument requires a operating voltage of 9 ... 32 V DC. Operating voltage and the digital bus signal are carried on the same two-wire connection cable. Power is supplied via the H1 power supply.

Connection cable

Connection is carried out with screened cable according to Fieldbus specification.

Use cable with round cross section for instruments with housing and cable gland. To ensure the seal effect of the cable gland (IP protection rating), find out which cable outer diameter the cable gland is suitable for.

Use a cable gland fitting the cable diameter.

Make sure that the entire installation is carried out according to the Fieldbus specification. In particular, make sure that the bus is terminated with suitable terminating resistors.

Cable screening and grounding

Make sure that the cable screen and grounding are carried out according to Fieldbus specification. We recommend to connect the cable screening to ground potential on both ends.

In systems with potential equalisation, connect the cable screening directly to ground potential at the power supply unit, in the connection box and at the sensor. The screen in the sensor must be connected directly to the internal ground terminal. The ground terminal outside on the housing must be connected to the potential equalisation (low impedance).

Cable glands

Metric threads

In the case of instrument housings with metric thread, the cable glands are screwed in at the factory. They are sealed with plastic plugs as transport protection.

You have to remove these plugs before electrical connection.

NPT thread

In the case of instrument housings with self-sealing NPT threads, it is not possible to have the cable entries screwed in at the factory. The free openings for the cable glands are therefore covered with red dust protection caps as transport protection.

Prior to setup you have to replace these protective caps with approved cable glands or close the openings with suitable blind plugs.

On plastic housings, the NPT cable gland or the Conduit steel tube must be screwed into the threaded insert without grease.

Max. torque for all housings, see chapter "*Technical data*".

5.2 Connecting

Connection technology

The voltage supply and signal output are connected via the spring-loaded terminals in the housing.

Connection to the display and adjustment module or to the interface adapter is carried out via contact pins in the housing.



Information:

The terminal block is pluggable and can be removed from the electronics. To do this, lift the terminal block with a small screwdriver and pull it out. When reinserting the terminal block, you should hear it snap in.

Connection procedure

Proceed as follows:

1. Unscrew the housing lid
2. If a display and adjustment module is installed, remove it by turning it slightly to the left
3. Loosen compression nut of the cable gland and remove blind plug
4. Remove approx. 10 cm (4 in) of the cable mantle, strip approx. 1 cm (0.4 in) of insulation from the ends of the individual wires
5. Insert the cable into the sensor through the cable entry



Fig. 20: Connection steps 5 and 6

- 1 Single chamber housing
- 2 Double chamber housing

6. Insert the wire ends into the terminals according to the wiring plan



Information:

Solid cores as well as flexible cores with wire end sleeves are inserted directly into the terminal openings. In case of flexible cores without end sleeves, press the terminal from above with a small screwdriver, the terminal opening is then free. When the screwdriver is released, the terminal closes again.

You can find further information on the max. wire cross-section under "*Technical data - Electromechanical data*".

7. Check the hold of the wires in the terminals by lightly pulling on them
 8. Connect the screen to the internal ground terminal, connect the external ground terminal to potential equalisation
 9. Tighten the compression nut of the cable entry gland. The seal ring must completely encircle the cable
 10. Reinsert the display and adjustment module, if one was installed
 11. Screw the housing lid back on
- The electrical connection is finished.

5.3 Single chamber housing



The following illustration applies to the non-Ex, Ex-ia and Ex-d version.

Electronics and connection compartment

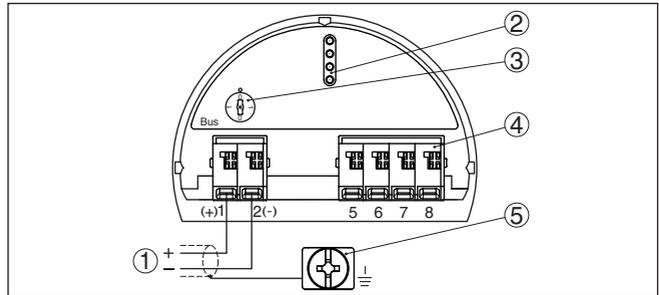

Fig. 21: Electronics and connection compartment - single chamber housing

- 1 Voltage supply, signal output
- 2 Contact pins for the display and adjustment module or interface adapter
- 3 Simulation switch ("1" = mode for simulation release)
- 4 For external display and adjustment unit
- 5 Ground terminal for connection of the cable screening

5.4 Double chamber housing



The following illustrations apply to the non-Ex as well as to the Ex-ia version.

Electronics compartment

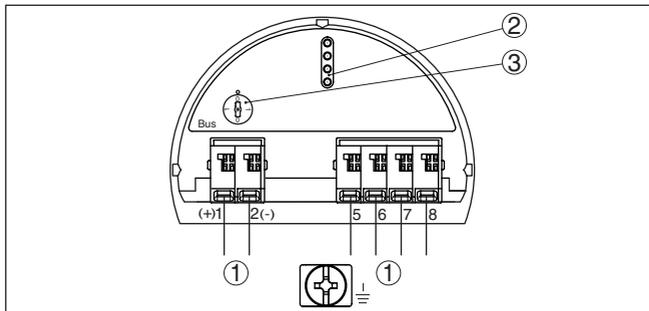

Fig. 22: Electronics compartment - double chamber housing

- 1 Internal connection to the connection compartment
- 2 Contact pins for the display and adjustment module or interface adapter
- 3 Simulation switch ("1" = mode for simulation release)

Connection compartment

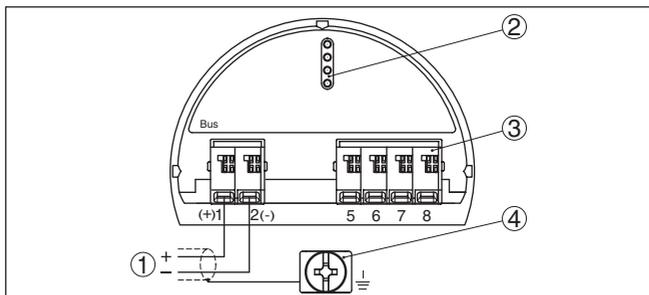

Fig. 23: Connection compartment - double chamber housing

- 1 Voltage supply, signal output
- 2 For display and adjustment module or interface adapter
- 3 For external display and adjustment unit
- 4 Ground terminal for connection of the cable screening

5.5 Double chamber housing Ex d

Electronics compartment

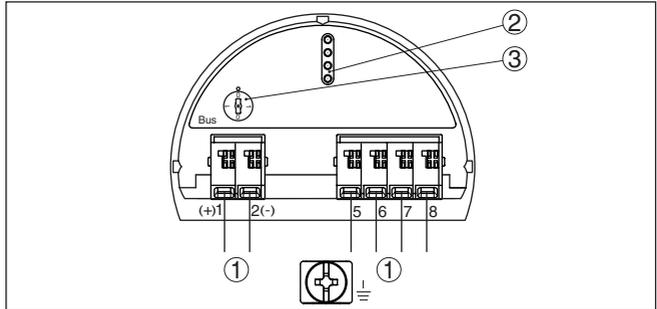

Fig. 24: Electronics compartment - double chamber housing

- 1 Internal connection to the connection compartment
- 2 Contact pins for the display and adjustment module or interface adapter
- 3 Simulation switch ("1" = mode for simulation release)

Connection compartment

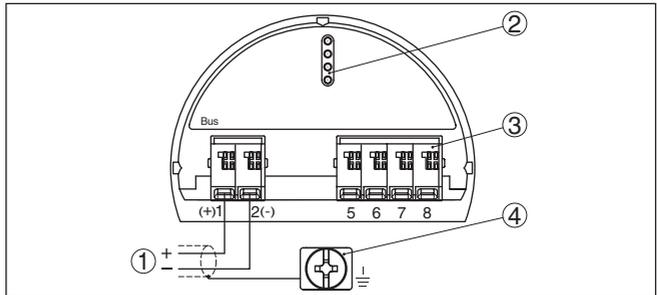

Fig. 25: Connection compartment - double chamber housing

- 1 Voltage supply, signal output
- 2 For display and adjustment module or interface adapter
- 3 For external display and adjustment unit
- 4 Ground terminal for connection of the cable screening

5.6 Housing IP 66/IP 68 (1 bar)

Wire assignment, connection cable

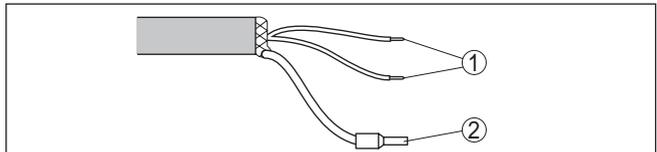

Fig. 26: Wire assignment in permanently connected connection cable

- 1 Brown (+) and blue (-) to power supply or to the processing system
- 2 Shielding

5.7 External housing with version IP 68 (25 bar)

Overview

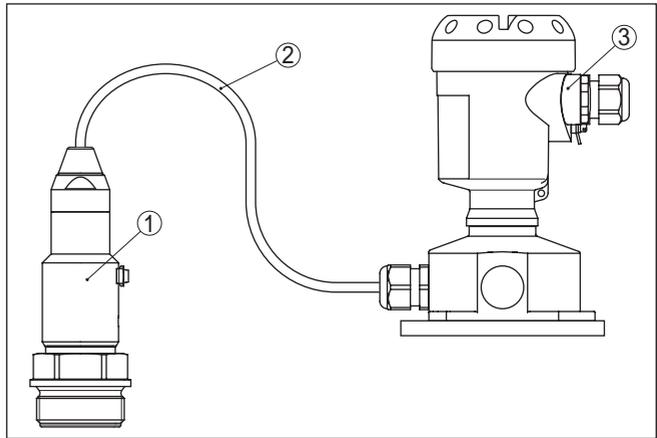

Fig. 27: CPT-2x in IP 68 version 25 bar with axial cable outlet, external housing

- 1 Transmitter
- 2 Connection cable
- 3 External housing

Electronics and connection compartment for power supply

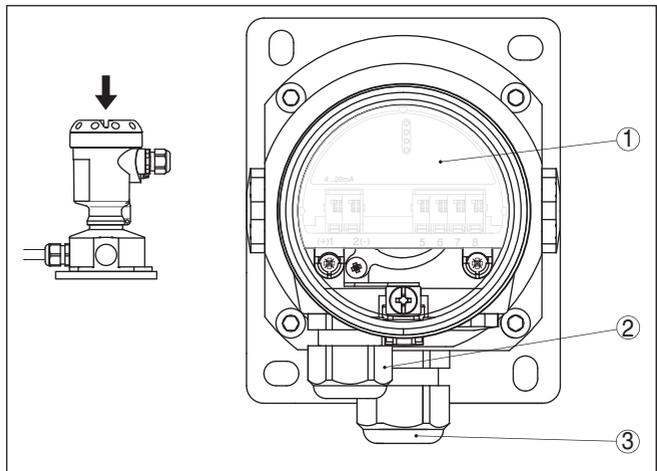

Fig. 28: Electronics and connection compartment

- 1 Electronics module
- 2 Cable gland for voltage supply
- 3 Cable gland for connection cable, transmitter

**Terminal compartment,
housing socket**

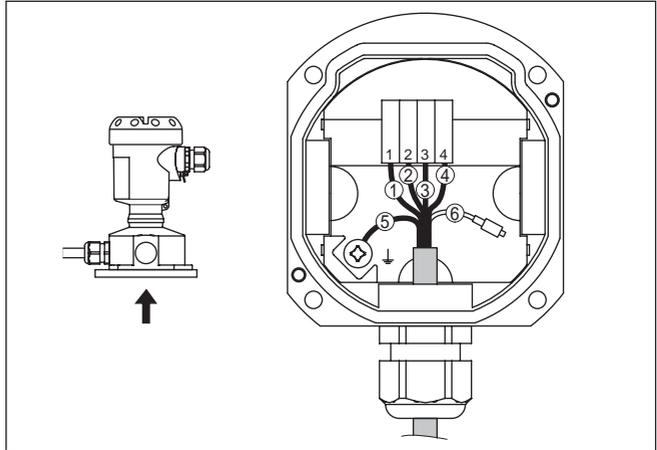

Fig. 29: Connection of the process component in the housing base

- 1 Yellow
- 2 White
- 3 Red
- 4 Black
- 5 Shielding
- 6 Breather capillaries

Electronics and connection compartment

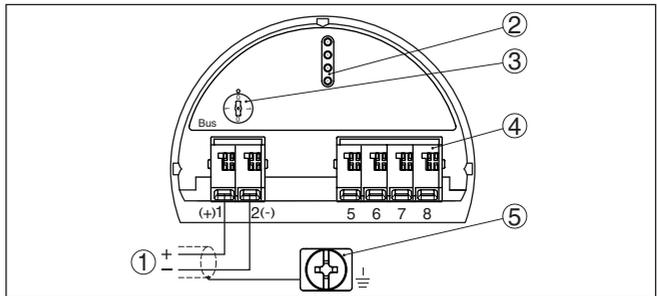

Fig. 30: Electronics and connection compartment - single chamber housing

- 1 Voltage supply, signal output
- 2 Contact pins for the display and adjustment module or interface adapter
- 3 Simulation switch ("1" = mode for simulation release)
- 4 For external display and adjustment unit
- 5 Ground terminal for connection of the cable screening

5.8 Switch-on phase

After connecting the instrument to power supply or after a voltage recurrence, the instrument carries out a self-check for approx. 5 s:

- Internal check of the electronics
- Indication of a status message on the display or PC

- Output signal at instruments with current output jumps to the set fault current

Then the actual measured value is output to the signal cable. The value takes into account settings that have already been carried out, e.g. default setting.

6 Set up with the display and adjustment module

6.1 Insert display and adjustment module

The display and adjustment module can be inserted into the sensor and removed again at any time. You can choose any one of four different positions - each displaced by 90°. It is not necessary to interrupt the power supply.

Proceed as follows:

1. Unscrew the housing lid
2. Place the display and adjustment module on the electronics in the desired position and turn it to the right until it snaps in.
3. Screw housing lid with inspection window tightly back on

Disassembly is carried out in reverse order.

The display and adjustment module is powered by the sensor, an additional connection is not necessary.



Fig. 31: Installing the display and adjustment module in the electronics compartment of the single chamber housing



Fig. 32: Installing the display and adjustment module in the double chamber housing

- 1 In the electronics compartment
- 2 In the connection compartment



Note:

If you intend to retrofit the instrument with a display and adjustment module for continuous measured value indication, a higher lid with an inspection glass is required.

6.2 Adjustment system

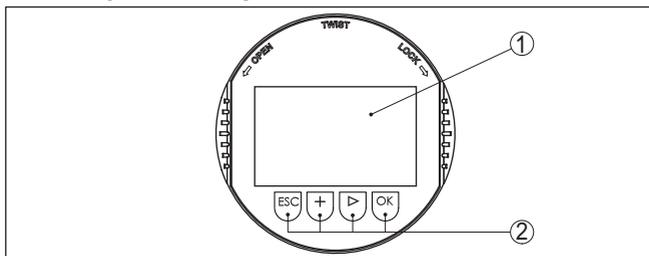

Fig. 33: Display and adjustment elements

- 1 LC display
- 2 Adjustment keys

Key functions

- **[OK]** key:
 - Move to the menu overview
 - Confirm selected menu
 - Edit parameter
 - Save value
- **[->]** key:
 - Change measured value presentation
 - Select list entry
 - Select menu items

- Select editing position
- **[+]** key:
 - Change value of the parameter
- **[ESC]** key:
 - Interrupt input
 - Jump to next higher menu

Adjustment system

The instrument is operated via the four keys of the display and adjustment module. The individual menu items are shown on the LC display. You can find the function of the individual keys in the previous illustration.

Time functions

When the **[+]** and **[->]** keys are pressed quickly, the edited value, or the cursor, changes one value or position at a time. If the key is pressed longer than 1 s, the value or position changes continuously.

When the **[OK]** and **[ESC]** keys are pressed simultaneously for more than 5 s, the display returns to the main menu. The menu language is then switched over to "English".

Approx. 60 minutes after the last pressing of a key, an automatic reset to measured value indication is triggered. Any values not confirmed with **[OK]** will not be saved.

6.3 Measured value indication

Measured value indication

With the **[->]** key you can move between three different indication modes.

In the first view, the selected measured value is displayed in large digits.

In the second view, the selected measured value and a corresponding bar graph presentation are displayed.

In the third view, the selected measured value as well as a second selectable value, e.g. the temperature, are displayed.



With the **"OK"** key you move (during the initial setup of the instrument) to the selection menu "Language".

Selection language

In this menu item, you can select the national language for further parameterization.



With the **[->]** button, you can select the requested language, with **"OK"** you confirm the selection and move to the main menu.

You can change your selection afterwards with the menu item "Setup - Display, Menu language".

6.4 Parameter adjustment - Quick setup

To quickly and easily adapt the sensor to the application, select the menu item "Quick setup" in the start graphic on the display and adjustment module.



Select the individual steps with the [->] key.

After the last step, "Quick setup terminated successfully" is displayed briefly.

The return to the measured value indication is carried out through the [->] or [ESC] keys or automatically after 3 s



Note:

You can find a description of the individual steps in the quick setup guide of the sensor.

You can find "Extended adjustment" in the next sub-chapter.

6.5 Parameter adjustment - Extended adjustment

For technically demanding measuring points, you can carry out extended settings in "Extended adjustment".



Main menu

The main menu is divided into five sections with the following functions:

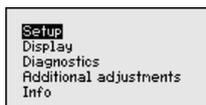

Setup: Settings, e.g., for measurement loop name, application, units, position correction, adjustment, signal output

Display: Settings, e.g., for language, measured value display, lighting

Diagnosis: Information, e.g. on instrument status, pointer, measurement reliability, simulation

Additional adjustments: PIN, date/time, reset, copy function

Info: Instrument name, hardware and software version, date of manufacture, device ID, sensor features



Note:

For optimum adjustment of the measuring point, the individual sub-menu items in the main menu item "Setup" should be selected one

after the other and provided with the correct parameters. If possible, go through the items in the given sequence.

The procedure is described below.

The following submenu points are available:

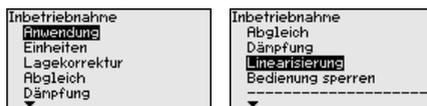

The submenu points are described below.

Setup - Application

In this menu item you activate/deactivate the slave sensor for electronic differential pressure and select the application.

CPT-2x can be used for process pressure and level measurement. Default setting is process pressure measurement. The mode can be changed in this adjustment menu.

If you have connected **no** slave sensor, you confirm this with "*Deactivate*".

Depending on the selected application, different subchapters in the following adjustment steps are important. There you can find the individual adjustment steps.

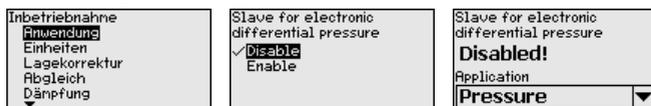

Enter the requested parameters via the appropriate keys, save your settings with **[OK]** and jump to the next menu item with the **[ESC]** and the **[->]** key.

Setup - Units

In this menu item, the adjustment units of the instrument are determined. The selection determines the unit displayed in the menu items "*Min. adjustment (Zero)*" and "*Max. adjustment (Span)*".

Unit of measurement:

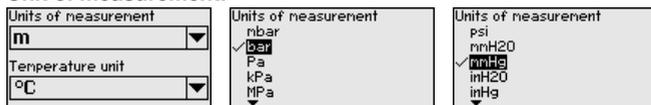

If the level should be adjusted in a height unit, the density of the medium must also be entered later during the adjustment.

In addition, the temperature unit of the instrument is specified. The selection determines the unit displayed in menu items "*Peak value, temperature*" and "in the variables of the digital output signal".

Temperature unit:

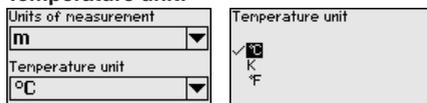

Enter the requested parameters via the appropriate keys, save your settings with **[OK]** and jump to the next menu item with the **[ESC]** and the **[->]** key.

Setup - Position correction

Especially with chemical seal systems, the installation position of the instrument can shift (offset) the measured value. Position correction compensates this offset. In the process, the actual measured value is taken over automatically. With relative pressure measuring cells a manual offset can also be carried out.



Note:

If the current measured value is automatically accepted, it must not be falsified by medium coverage or static pressure.

With the manual position correction, the offset value can be determined by the user. Select for this purpose the function "Edit" and enter the requested value.

Save your settings with **[OK]** and move with **[ESC]** and **[->]** to the next menu item.

After the position correction is carried out, the actual measured value is corrected to 0. The corrective value appears with an inverse sign as offset value in the display.

The position correction can be repeated as often as necessary. However, if the sum of the corrective values exceeds 20 % of the nominal measuring range, then no position correction is possible.

Setup - Adjustment

CPT-2x always measures pressure independently of the process variable selected in the menu item "Application". To output the selected process variable correctly, an allocation of the output signal to 0 % and 100 % must be carried out (adjustment).

With the application "Level", the hydrostatic pressure, e.g. with full and empty vessel, is entered for adjustment. See following example:

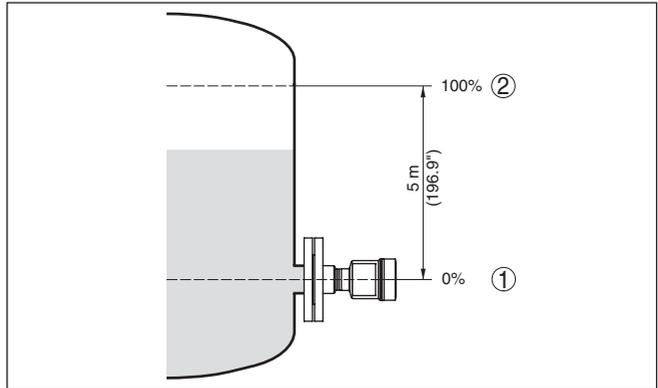

Fig. 34: Parameter adjustment example "Min./max. adjustment, level measurement"

- 1 Min. level = 0 % corresponds to 0.0 mbar
- 2 Max. level = 100 % corresponds to 490.5 mbar

If these values are not known, an adjustment with filling levels of e.g. 10 % and 90 % is also possible. By means of these settings, the real filling height is then calculated.

The actual product level during this adjustment is not important, because the min./max. adjustment is always carried out without changing the product level. These settings can be made ahead of time without the instrument having to be installed.



Note:

If the adjustment ranges are exceeded, the entered value will not be accepted. Editing can be interrupted with **[ESC]** or corrected to a value within the adjustment ranges.

For the other process variables such as e.g. process pressure, differential pressure or flow, the adjustment is performed in like manner.

Setup - Zero adjustment

Proceed as follows:

1. Select the menu item "Setup" with **[>]** and confirm with **[OK]**.
Now select with **[>]** the menu item "Zero adjustment" and confirm with **[OK]**.

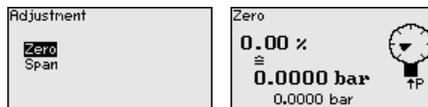

2. Edit the mbar value with **[OK]** and set the cursor to the requested position with **[>]**.

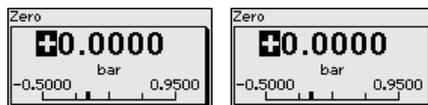

3. Set the requested mbar value with **[+]** and store with **[OK]**.

- Go with **[ESC]** and **[->]** to the span adjustment

The zero adjustment is finished.



Information:

The Zero adjustment shifts the value of the span adjustment. The span, i.e. the difference between these values, however, remains unchanged.

For an adjustment with pressure, simply enter the actual measured value indicated at the bottom of the display.

If the adjustment ranges are exceeded, the message "Outside parameter limits" appears. The editing procedure can be aborted with **[ESC]** or the displayed limit value can be accepted with **[OK]**.

Setup - Span adjustment

Proceed as follows:

- Select with **[->]** the menu item Span adjustment and confirm with **[OK]**.

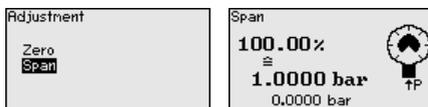

- Edit the mbar value with **[OK]** and set the cursor to the requested position with **[->]**.

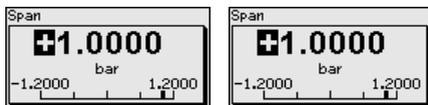

- Set the requested mbar value with **[+]** and store with **[OK]**.

For an adjustment with pressure, simply enter the actual measured value indicated at the bottom of the display.

If the adjustment ranges are exceeded, the message "Outside parameter limits" appears. The editing procedure can be aborted with **[ESC]** or the displayed limit value can be accepted with **[OK]**.

The span adjustment is finished.

Setup - Min. adjustment Level

Proceed as follows:

- Select the menu item "Setup" with **[->]** and confirm with **[OK]**.
Now select with **[->]** the menu item "Adjustment", then "Min. adjustment" and confirm with **[OK]**.



- Edit the percentage value with **[OK]** and set the cursor to the requested position with **[->]**.
- Set the requested percentage value (e.g. 10 %) with **[+]** and save with **[OK]**. The cursor jumps now to the pressure value.
- Enter the pressure value corresponding to the min. level (e.g. 0 mbar).

- Save settings with **[OK]** and move with **[ESC]** and **[->]** to the max. adjustment.

The min. adjustment is finished.

For an adjustment with filling, simply enter the actual measured value indicated at the bottom of the display.

Setup - Max. adjustment Level

Proceed as follows:

- Select with **[->]** the menu item Max. adjustment and confirm with **[OK]**.



- Edit the percentage value with **[OK]** and set the cursor to the requested position with **[->]**.
- Set the requested percentage value (e.g. 90 %) with **[+]** and save with **[OK]**. The cursor jumps now to the pressure value.
- Enter the pressure value for the full vessel (e.g. 900 mbar) corresponding to the percentage value.
- Save settings with **[OK]**

The max. adjustment is finished.

For an adjustment with filling, simply enter the actual measured value indicated at the bottom of the display.

Setup - Damping

To damp process-dependent measured value fluctuations, set an integration time of 0 ... 999 s in this menu item. The increment is 0.1 s.



The setting in the delivery status depends on the sensor type.

Setup - Linearisation

A linearization is necessary for all vessels in which the vessel volume does not increase linearly with the level - e.g. a horizontal cylindrical or spherical tank - and the indication or output of the volume is required. Corresponding linearization curves are preprogrammed for these vessels. They represent the correlation between the level percentage and vessel volume. The linearization applies to the measured value indication and the current output.

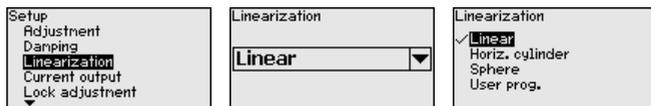

Lock/unlock setup - Adjustment

In the menu item "Lock/unlock adjustment" you safeguard the sensor parameters against unauthorized or unintentional modifications.

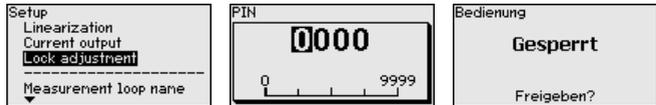

With active PIN, only the following adjustment functions are possible without entering a PIN:

- Select menu items and show data
- Read data from the sensor into the display and adjustment module

Releasing the sensor adjustment is also possible in any menu item by entering the PIN.



Caution:

With active PIN, adjustment via PACTware/DTM and other systems is also blocked.

Display - Language

This menu item enables the setting of the requested national language.

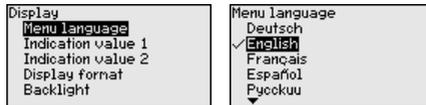

The following languages are available:

- German
- English
- French
- Spanish
- Russian
- Italian
- Dutch
- Portuguese
- Japanese
- Chinese
- Polish
- Czech
- Turkish

In delivery status, the CPT-2x is set to English.

Display - Displayed value 1 and 2

In this menu item, you define which measured value is displayed.

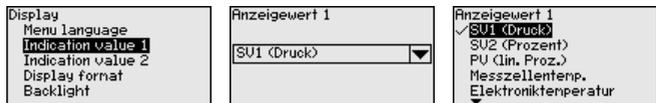

The default setting for the display value is "Lin. percent".

Display - Display format 1 and 2

In this menu item you define the number of decimal positions with which the measured value is displayed.



The default setting for the display format is "Automatic".

Display - Backlight

The display and adjustment module has a backlight for the display. In this menu item you can switch on the lighting. You can find the required operating voltage in chapter "Technical data".

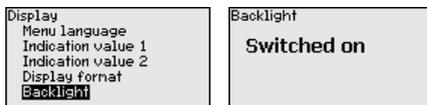

In delivery status, the lighting is switched on.

Diagnostics - Device status

In this menu item, the device status is displayed.

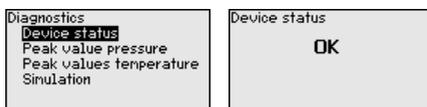

In case of error, e.g. the error code F017, e.g. the error description "Adjustment span too small" and a four digit figure are displayed for service purposes. You can find the error codes with description, reason as well as rectification in chapter "Asset Management".

Diagnostics - Peak values, pressure

The respective min. and max. measured values are saved in the sensor. The two values are displayed in menu item "Peak values, pressure".

In another window you can carry out a reset of the peak values separately.

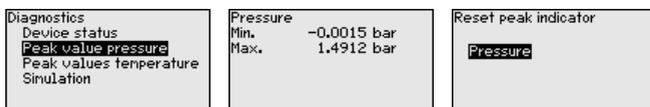

Diagnostics - Peak values, temperature

The respective min. and max. measured values of the measuring cell and the electronics temperature are stored in the sensor. In menu item "Peak value, temperature", both values are displayed.

In another window you can carry out a reset of the two peak values separately.

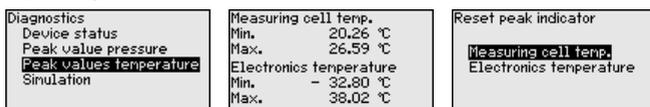

Diagnosis - Simulation

In this menu item you simulate measured values. Hence, the signal path can be tested via the bus system to the input card of the control system.

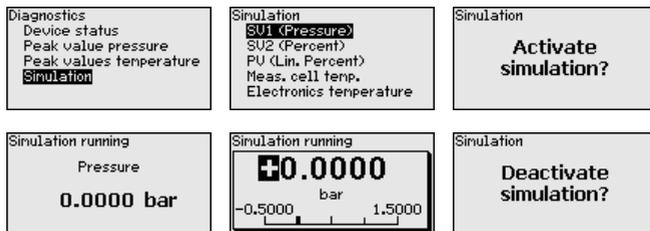

Select the requested simulation variable and set the requested value.

To deactivate the simulation, you have to push the **[ESC]** key and confirm the message "Deactivate simulation" with the **[OK]** key.



Caution:

During simulation, the simulated value is output as digital signal. The status message along with the Asset Management function is "Maintenance".



Information:

The sensor terminates the simulation automatically after 60 minutes.

Additional settings - Date/Time

In this menu item, you adjust the internal clock of the sensor. There is no adjustment for summer/winter (daylight saving) time.

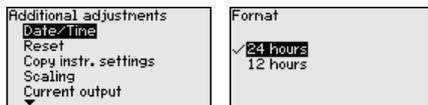

Additional settings - Reset

After a reset, certain parameter adjustments made by the user are reset.



The following reset functions are available:

Delivery status: Restores the parameter settings at the time of shipment from the factory, incl. the order-specific settings. Any user-defined linearisation curve as well as the measured value memory are deleted.

Basic settings: Resets the parameter settings, incl. special parameters, to the default values of the respective instrument. Any programmed linearisation curve as well as the measured value memory are deleted.

The following table shows the default values of the instrument. Depending on the instrument version or application, all menu items may not be available or some may be differently assigned:

Reset - Setup

Menu item	Parameter	Default value
Application	Application	Level
	Slave for electronic differential pressure	Deactivated
Units	Unit of measurement	mbar (with nominal measuring range ≤ 400 mbar) bar (with nominal measuring ranges ≥ 1 bar)
	Temperature unit	$^{\circ}\text{C}$
Position correction		0.00 bar
Adjustment	Zero/Min. adjustment	0.00 bar 0.00 %
	Span/Max. adjustment	Nominal measuring range in bar 100.00 %
Damping	Integration time	1 s
Linearization		Linear
Lock adjustment		Released

Reset - Display

Menu item	Default value
Menu language	Selected language
Displayed value 1	Signal output in %
Displayed value 2	Ceramic measuring cell: Measuring cell temperature in $^{\circ}\text{C}$ Metallic measuring cell: Electronics temperature in $^{\circ}\text{C}$
Display format 1 and 2	Number of positions after the decimal point, automatically
Backlight	Switched on

Reset - Diagnosis

Menu item	Parameter	Default value
Sensor status		-
Peak value	Pressure	Actual measured value
	Temperature	Actual temperature values from measuring cell, electronics
Simulation		Process pressure

Reset - Additional settings

Menu item	Parameter	Default value
PIN		0000
Date/Time		Actual date/Actual time
Copy instrument settings		

Menu item	Parameter	Default value
Special parameters		No reset
Scaling	Scaling size	Volume in l
	Scaling format	0 % corresponds to 0 l 100 % corresponds to 0 l

Additional settings - Copy instrument settings

The instrument settings are copied with this function. The following functions are available:

- **Read from sensor:** Read data from sensor and store into the display and adjustment module
- **Write into sensor:** Store data from the display and adjustment module back into the sensor

The following data or settings for adjustment of the display and adjustment module are saved:

- All data of the menu "Setup" and "Display"
- In the menu "Additional adjustments" the items "Reset, Date/Time"
- The user-programmable linearization curve



The copied data are permanently saved in an EEPROM memory in the display and adjustment module and remain there even in case of power failure. From there, they can be written into one or more sensors or kept as backup for a possible electronics exchange.



Note:

Before the data are saved in the sensor, a safety check is carried out to determine if the data match the sensor. In the process the sensor type of the source data as well as the target sensor are displayed. If the data do not match, a fault message is outputted or the function is blocked. The data are saved only after release.

Additional settings - Special parameters

In this menu item you gain access to the protected area where you can enter special parameters. In exceptional cases, individual parameters can be modified in order to adapt the sensor to special requirements.

Change the settings of the special parameters only after having contacted our service staff.



Info - Instrument name

In this menu item, you can read out the instrument name and the instrument serial number:

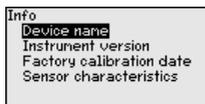

Info - Instrument version In this menu item, the hardware and software version of the sensor is displayed.

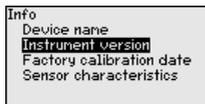

Info - Factory calibration date In this menu item, the date of factory calibration of the sensor as well as the date of the last change of sensor parameters are displayed via the display and adjustment module or via the PC.

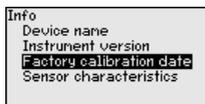

Info - Device ID In this menu item, the identification number of the instrument in a Foundation Fieldbus system is shown.

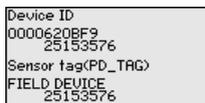

Info - Sensor characteristics In this menu item, the features of the sensor such as approval, process fitting, seal, measuring range, electronics, housing and others are displayed.

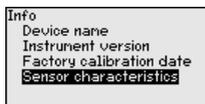

6.6 Saving the parameterisation data

On paper

We recommended writing down the adjustment data, e.g. in this operating instructions manual, and archiving them afterwards. They are thus available for multiple use or service purposes.

In the display and adjustment module

If the instrument is equipped with a display and adjustment module, the parameter adjustment data can be saved therein. The procedure is described in menu item "*Copy device settings*".

7 Setup with PACTware

7.1 Parameter adjustment

The further setup steps with detailed descriptions can be found in the online help of PACTware and the DTMs.



Note:

Keep in mind that for the setup of model CPT-2x, the current version of the DTM-Collection must be used.

The latest DTM Collection and PACTware version can be downloaded free of charge via the Internet.

7.2 Saving the parameterisation data

We recommend documenting or saving the parameterisation data via PACTware. That way the data are available for multiple use or service purposes.

8 Diagnosis, asset management and service

8.1 Maintenance

Maintenance

If the device is used properly, no special maintenance is required in normal operation.

Precaution measures against buildup

In some applications, product buildup on the diaphragm can influence the measuring result. Depending on the sensor and application, take precautions to ensure that heavy buildup, and especially a hardening thereof, is avoided.

Cleaning

The cleaning helps that the type label and markings on the instrument are visible.

Take note of the following:

- Use only cleaning agents which do not corrode the housings, type label and seals
- Use only cleaning methods corresponding to the housing protection rating

8.2 Cleaning - hygienic connection with compression nut

Overview

The hygienic connection with compression nut can be disassembled and the diaphragm cleaned.

The following graphic shows the structure:

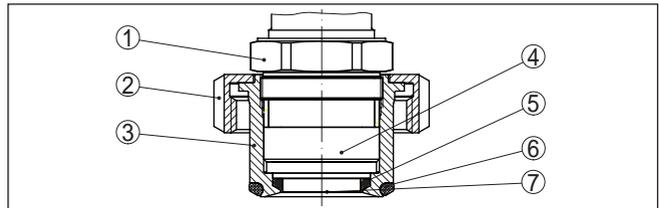

Fig. 35: CPT-2x, structure of the hygienic connection with compression nut

- 1 Hexagon
- 2 Compression nut
- 3 Process fitting
- 4 Process module
- 5 Form seal for the measuring cell
- 6 O-ring seal for the process fitting
- 7 Diaphragm

Procedure

To do so, proceed as follows:

1. Loosen compression nut and remove the pressure transmitter from the welded socket
2. Remove the O-ring seal for the process fitting
3. Clean the diaphragm with brass brush and cleaning detergent
4. Loosen the hexagon and remove the process component from the process fitting

5. Remove the form seal for the measuring cell and remove it by a new one
6. Screw the process component into the process fitting, tighten the hexagon (wrench size see chapter "*Dimensions*", max. torque see chapter "*Technical data*")
7. Insert new O-ring seal for the process fitting
8. Install the process pressure transmitter in the welded socket, tighten compression nut

The cleaning is finished.

The pressure transmitter is directly ready for operation, a fresh adjustment is not required.

8.3 Diagnosis memory

The instrument has several memories available for diagnostic purposes. The data remain there even in case of voltage interruption.

Measured value memory

Up to 100,000 measured values can be stored in the sensor in a ring memory. Each entry contains date/time as well as the respective measured value.

Depending on the instrument version, values that can be stored are for example:

- Level
- Process pressure
- Differential pressure
- Static pressure
- Percentage value
- Scaled values
- Current output
- Lin. percent
- Measuring cell temperature
- Electronics temperature

When the instrument is shipped, the measured value memory is active and stores pressure value and measuring cell temperature every 10 s, with electronic differential pressure also the static pressure.

The requested values and recording conditions are set via a PC with PACTware/DTM or the control system with EDD. Data are thus read out and also reset.

Event memory

Up to 500 events are automatically stored with a time stamp in the sensor (non-deletable). Each entry contains date/time, event type, event description and value. Event types are for example:

- Modification of a parameter
- Switch-on and switch-off times
- Status messages (according to NE 107)
- Error messages (according to NE 107)

The data are read out via a PC with PACTware/DTM or the control system with EDD.

8.4 Asset Management function

Monitoring and output

The device is equipped with self-monitoring and diagnostics in accordance with NE 107 and VDI/VDE 2650. The operating status is output via status messages. Depending on instrument type and version, this is done via display and adjustment unit, VEGA Tools app, PACTware/DTM or EDD or LED illuminated ring.

Status messages

The status messages are divided into the following categories:

- Failure
- Function check
- Out of specification
- Maintenance requirement

and explained by pictographs:

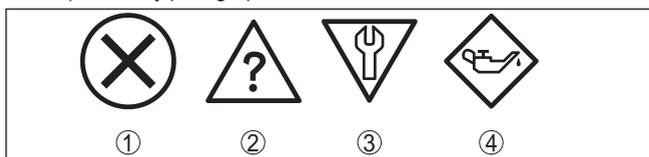

Fig. 36: Pictographs of the status messages

- 1 Failure - red
- 2 Out of specification - yellow
- 3 Function check - orange
- 4 Maintenance - blue

Failure: Due to a malfunction in the instrument, a fault message is output.

This status message is always active. It cannot be deactivated by the user.

Function check: The instrument is being worked on, the measured value is temporarily invalid (for example during simulation).

This status message is inactive by default. It can be activated by the user via PACTware/DTM or EDD.

Out of specification: The measured value is unreliable because an instrument specification was exceeded (e.g. electronics temperature).

This status message is inactive by default. It can be activated by the user via PACTware/DTM or EDD.

Maintenance: Due to external influences, the instrument function is limited. The measurement is affected, but the measured value is still valid. Plan in maintenance for the instrument because a failure is expected in the near future (e.g. due to buildup).

This status message is inactive by default. It can be activated by the user via PACTware/DTM or EDD.

Failure

Code Text message	Cause	Rectification	DevSpec Diagnosis Bits
F013 No valid measured value available	<ul style="list-style-type: none"> ● Gauge pressure or low pressure ● Measuring cell defective 	<ul style="list-style-type: none"> ● Exchange measuring cell ● Send instrument for repair 	Bit 0
F017 Adjustment span too small	<ul style="list-style-type: none"> ● Adjustment not within specification 	<ul style="list-style-type: none"> ● Change the adjustment according to the limit values 	Bit 1
F025 Error in the linearization table	<ul style="list-style-type: none"> ● Index markers are not continuously rising, for example illogical value pairs 	<ul style="list-style-type: none"> ● Check linearisation table ● Delete table/Create new 	Bit 2
F036 no operable sensor software	<ul style="list-style-type: none"> ● Failed or interrupted software update 	<ul style="list-style-type: none"> ● Repeat software update ● Check electronics version ● Exchanging the electronics ● Send instrument for repair 	Bit 3
F040 Error in the electronics	<ul style="list-style-type: none"> ● Hardware defect 	<ul style="list-style-type: none"> ● Exchanging the electronics ● Send instrument for repair 	Bit 4
F041 Communication error	<ul style="list-style-type: none"> ● No connection to the sensor electronics 	<ul style="list-style-type: none"> ● Check connection between sensor and main electronics (with separate version) 	Bit 13
F042 Communication error Slave	<ul style="list-style-type: none"> ● No connection to the Slave 	<ul style="list-style-type: none"> ● Check connection between Master and Slave 	Bit 28 of Byte 0 ... 5
F080 General software error	<ul style="list-style-type: none"> ● General software error 	<ul style="list-style-type: none"> ● Disconnect operating voltage briefly 	Bit 5
F105 Measured value is determined	<ul style="list-style-type: none"> ● The instrument is still in the start phase, the measured value could not yet be determined 	<ul style="list-style-type: none"> ● Wait for the end of the switch-on phase 	Bit 6
F113 Communication error	<ul style="list-style-type: none"> ● Error in the internal instrument communication 	<ul style="list-style-type: none"> ● Disconnect operating voltage briefly ● Send instrument for repair 	Bit 12
F260 Error in the calibration	<ul style="list-style-type: none"> ● Error in the calibration carried out in the factory ● Error in the EEPROM 	<ul style="list-style-type: none"> ● Exchanging the electronics ● Send instrument for repair 	Bit 8
F261 Error in the instrument settings	<ul style="list-style-type: none"> ● Error during setup ● Error when carrying out a reset 	<ul style="list-style-type: none"> ● Repeat setup ● Repeat reset 	Bit 9

Code Text message	Cause	Rectification	DevSpec Diagnosis Bits
F264 Installation/Setup error	<ul style="list-style-type: none"> ● Inconsistent settings (e.g.: distance, adjustment units with application process pressure) for selected application ● Invalid sensor configuration (e.g.: application electronic differential pressure with connected differential pressure measuring cell) 	<ul style="list-style-type: none"> ● Modify settings ● Modify connected sensor configuration or application 	Bit 10
F265 Measurement function disturbed	<ul style="list-style-type: none"> ● Sensor no longer carries out a measurement 	<ul style="list-style-type: none"> ● Carry out a reset ● Disconnect operating voltage briefly 	Bit 11

Tab. 5: Error codes and text messages, information on causes as well as corrective measures

Function check

Code Text message	Cause	Rectification	DevSpec Diagnosis Bits
C700 Simulation active	<ul style="list-style-type: none"> ● A simulation is active 	<ul style="list-style-type: none"> ● Finish simulation ● Wait for the automatic end after 60 mins. 	Bit 27

Tab. 6: Error codes and text messages, information on causes as well as corrective measures

Out of specification

Code Text message	Cause	Rectification	DevSpec Diagnosis Bits
S600 Impermissible electronics temperature	<ul style="list-style-type: none"> ● Temperature of the electronics in the non-specified range 	<ul style="list-style-type: none"> ● Check ambient temperature ● Insulate electronics ● Use instrument with higher temperature range 	Bit 23
S603 Impermissible operating voltage	<ul style="list-style-type: none"> ● Operating voltage below specified range 	<ul style="list-style-type: none"> ● Check electrical connection ● If necessary, increase operating voltage 	Bit 26
S605 Impermissible pressure value	<ul style="list-style-type: none"> ● Measured process pressure below or above the adjustment range 	<ul style="list-style-type: none"> ● Check nominal measuring range of the instrument ● If necessary, use an instrument with a higher measuring range 	Bit 29

Tab. 7: Error codes and text messages, information on causes as well as corrective measures

Maintenance

Code Text message	Cause	Rectification	DevSpec Diagnosis Bits
M500 Error in the delivery status	<ul style="list-style-type: none"> ● The data could not be restored during the reset to delivery status 	<ul style="list-style-type: none"> ● Repeat reset ● Load XML file with sensor data into the sensor 	Bit 15

Code Text message	Cause	Rectification	DevSpec Diagnosis Bits
M501 Error in the non-active linearisation table	<ul style="list-style-type: none"> ● Index markers are not continuously rising, for example illogical value pairs 	<ul style="list-style-type: none"> ● Check linearisation table ● Delete table/Create new 	Bit 16
M502 Error in the event memory	<ul style="list-style-type: none"> ● Hardware error EEPROM 	<ul style="list-style-type: none"> ● Exchanging the electronics ● Send instrument for repair 	Bit 17
M504 Error at a device interface	<ul style="list-style-type: none"> ● Hardware defect 	<ul style="list-style-type: none"> ● Exchanging the electronics ● Send instrument for repair 	Bit 19
M507 Error in the instrument settings	<ul style="list-style-type: none"> ● Error during setup ● Error when carrying out a reset 	<ul style="list-style-type: none"> ● Carry out reset and repeat setup 	Bit 22

Tab. 8: Error codes and text messages, information on causes as well as corrective measures

8.5 Rectify faults

Reaction when malfunction occurs

The operator of the system is responsible for taking suitable measures to rectify faults.

Fault rectification

The first measures are:

- Evaluation of fault messages
- Checking the output signal
- Treatment of measurement errors

A smartphone/tablet with the VEGA Tools app or a PC/notebook with the software PACTware and the suitable DTM offer you further comprehensive diagnostic possibilities. In many cases, the causes can be determined in this way and the faults eliminated.

Reaction after fault rectification

Depending on the reason for the fault and the measures taken, the steps described in chapter "Setup" must be carried out again or must be checked for plausibility and completeness.

8.6 Exchange process module on version IP 68 (25 bar)

On version IP 68 (25 bar), the user can exchange the process module on site. Connection cable and external housing can be kept.

Required tools:

- Hexagon key wrench, size 2



Caution:

The exchange may only be carried out in the complete absence of line voltage.



In Ex applications, only a replacement part with appropriate Ex approval may be used.

**Caution:**

During exchange, protect the inner side of the parts against contamination and moisture.

Proceed as follows when carrying out the exchange:

1. Loosen the fixing screw with the hexagon key wrench
2. Carefully detach the cable assembly from the process module

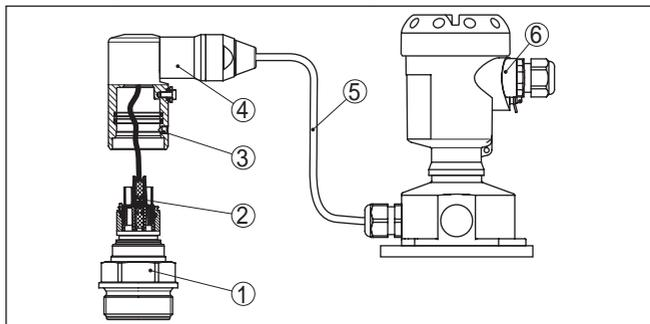

Fig. 37: CPT-2x in IP 68 version, 25 bar and lateral cable outlet, external housing

- 1 Process module
- 2 Plug connector
- 3 Fixing screw
- 4 Cable assembly
- 5 Connection cable
- 6 External housing

3. Loosen the plug connector
4. Mount the new process module on the measuring point
5. Plug the connector back in
6. Mount the cable assembly on the process module and turn it to the desired position
7. Tighten the fixing screw with the hexagon key wrench

The exchange is finished.

8.7 Instrument repair

You can find information for a return shipment under "Service" on our local website.

If a repair is necessary, please proceed as follows:

- Complete one form for each instrument
- If necessary, state a contamination
- Clean the instrument and pack it damage-proof
- Attach the completed form and possibly also a safety data sheet to the instrument

9 Dismount

9.1 Dismounting steps

**Warning:**

Before dismantling, be aware of dangerous process conditions such as e.g. pressure in the vessel or pipeline, high temperatures, corrosive or toxic products etc.

Take note of chapters "*Mounting*" and "*Connecting to voltage supply*" and carry out the listed steps in reverse order.

9.2 Disposal

The instrument consists of materials which can be recycled by specialised recycling companies. We use recyclable materials and have designed the electronics to be easily separable.

WEEE directive

The instrument does not fall in the scope of the EU WEEE directive. Article 2 of this Directive exempts electrical and electronic equipment from this requirement if it is part of another instrument that does not fall in the scope of the Directive. These include stationary industrial plants.

Pass the instrument directly on to a specialised recycling company and do not use the municipal collecting points.

If you have no way to dispose of the old instrument properly, please contact us concerning return and disposal.

10 Supplement

10.1 Technical data

Materials and weights

Materials, wetted parts

Process fitting	316L, PVDF, Alloy C22 (2.4602), Alloy C276 (2.4819), Duplex steel (1.4462), Titanium Grade 2
Diaphragm	Sapphire-ceramic® (> 99.9 % Al ₂ O ₃ ceramic)
Joining material measuring cell	Glass (with double and form seal, non-wetted parts)
Measuring cell seal	
– Standard (O-ring seal)	FKM (VP2/A, A+P 70.16), EPDM (A+P 70.10-02), FFKM (Kalrez 6375, Perlast G75S, Perlast G75B)
– Hygienic fitting with compression nut (form seal)	FKM (ET 6067), EPDM (EPDM 7076), FFKM (Chemraz 535), FEPM (Fluoraz SD890)
Seal for process fitting (in the scope of delivery)	
– Thread G1½ (EN 837), G1½ (DIN 3852-A)	Klingersil C-4400
– Thread M44 x 1.25 (DIN 13), M30 x 1.5	FKM, FFKM, EPDM
– Hygienic connection with compression nut	FKM, EPDM, FFKM, FEPM
Surface quality, hygienic fittings, typ.	
– Process fitting	R _a < 0.8 µm
– Diaphragm	R _a < 0.5 µm

Materials, non-wetted parts

Sensor housing

– Housing	Plastic PBT (Polyester), Aluminium AlSi10Mg (powder-coated, basis: Polyester), 316L
– Cable gland	PA, stainless steel, brass
– Cable gland: Seal, closure	NBR, PA
– Seal, housing lid	Silicone SI 850 R, NBR silicone-free
– Inspection window housing cover	Polycarbonate (UL-746-C listed), glass ¹⁾
– Ground terminal	316L

External housing - deviating materials

– Housing and socket	Plastic PBT (Polyester), 316L
– Socket seal	EPDM
– Seal below wall mounting plate ²⁾	EPDM
– Inspection window housing cover	Polycarbonate (UL-746-C listed)
Ground terminal	316Ti/316L

¹⁾ Glass with Aluminium and stainless steel precision casting housing

²⁾ Only for 316L with 3A approval

Connection cable with IP 68 (25 bar)³⁾

- Cable cover PE, PUR
- Type label support on cable PE hard

Connection cable with IP 68 (1 bar)⁴⁾ PE, PUR

Weights

Total weight CPT-2x approx. 0.8 ... 8 kg (1.764 ... 17.64 lbs), depending on process fitting and housing

Torques

Max. torque for process fitting

- G½, G¾ 30 Nm (22.13 lbf ft)
- Fittings according to 3A with exchangeable sealing 20 Nm (14.75 lbf ft)
- Hygienic fitting with compression nut (hexagon) 40 Nm (29.50 lbf ft)
- G1, M30 x 1.5 50 Nm (36.88 lbf ft)
- G1 for PASVE 100 Nm (73.76 lbf ft)
- G1½ 200 Nm (147.5 lbf ft)

Max. torque for screws

- PMC 1", PMC 1¼" 2 Nm (1.475 lbf ft)
- PMC 1½" 5 Nm (3.688 lbf ft)

Max. torque for NPT cable glands and Conduit tubes

- Plastic housing 10 Nm (7.376 lbf ft)
- Aluminium/Stainless steel housing 50 Nm (36.88 lbf ft)

Input variable

The specifications are only an overview and refer to the measuring cell. Limitations due to the material and version of the process fitting as well as the selected pressure type are possible. The specifications on the nameplate apply.

Nominal measuring ranges and overload capability in bar/kPa

Nominal range	Overload capability	
	Maximum pressure	Minimum pressure
Gauge pressure		
0 ... +0.025 bar/0 ... +2.5 kPa (only for measuring cell ø 28 mm)	+5 bar/+500 kPa	-0.05 bar/-5 kPa
0 ... +0.1 bar/0 ... +10 kPa	+15 bar/+1500 kPa	-0.2 bar/-20 kPa
0 ... +0.4 bar/0 ... +40 kPa	+30 bar/+3000 kPa	-0.8 bar/-80 kPa
0 ... +1 bar/0 ... +100 kPa	+35 bar/+3500 kPa	-1 bar/-100 kPa
0 ... +2.5 bar/0 ... +250 kPa	+50 bar/+5000 kPa	-1 bar/-100 kPa

³⁾ Between transmitter and external electronics housing.

⁴⁾ Fix connected to the sensor.

Nominal range	Overload capability	
	Maximum pressure	Minimum pressure
0 ... +5 bar/0 ... +500 kPa	+65 bar/+6500 kPa	-1 bar/-100 kPa
0 ... +10 bar/0 ... +1000 kPa	+90 bar/+9000 kPa	-1 bar/-100 kPa
0 ... +25 bar/0 ... +2500 kPa	+125 bar/+12500 kPa	-1 bar/-100 kPa
0 ... +60 bar/0 ... +6000 kPa	+200 bar/+20000 kPa	-1 bar/-100 kPa
0 ... +100 bar/0 ... +10000 kPa (only for measuring cell ø 28 mm)	+200 bar/+20000 kPa	-1 bar/-100 kPa
-1 ... 0 bar/-100 ... 0 kPa	+35 bar/+3500 kPa	-1 bar/-100 kPa
-1 ... +1.5 bar/-100 ... +150 kPa	+40 bar/+4000 kPa	-1 bar/-100 kPa
-1 ... +10 bar/-100 ... +1000 kPa	+90 bar/+9000 kPa	-1 bar/-100 kPa
-1 ... +25 bar/-100 ... +2500 kPa	+125 bar/+12500 kPa	-1 bar/-100 kPa
-1 ... +60 bar/-100 ... +6000 kPa	+200 bar/+20000 kPa	-1 bar/-100 kPa
-1 ... +100 bar/-100 ... +10000 kPa (only for measuring cell ø 28 mm)	+200 bar/+20000 kPa	-1 bar/-100 kPa
-0.025 ... +0.025 bar/-2.5 ... +2.5 kPa	+5 bar/+500 kPa	-0.05 bar/-5 kPa
-0.05 ... +0.05 bar/-5 ... +5 kPa	+15 bar/+1500 kPa	-0.2 bar/-20 kPa
-0.2 ... +0.2 bar/-20 ... +20 kPa	+20 bar/+2000 kPa	-0.4 bar/-40 kPa
-0.5 ... +0.5 bar/-50 ... +50 kPa	+35 bar/+3500 kPa	-1 bar/-100 kPa
Absolute pressure		
0 ... 0.1 bar/0 ... 10 kPa	15 bar/1500 kPa	0 bar abs.
0 ... 1 bar/0 ... 100 kPa	35 bar/3500 kPa	0 bar abs.
0 ... 2.5 bar/0 ... 250 kPa	50 bar/5000 kPa	0 bar abs.
0 ... +5 bar/0 ... +500 kPa	65 bar/+6500 kPa	0 bar abs.
0 ... 10 bar/0 ... 1000 kPa	90 bar/9000 kPa	0 bar abs.
0 ... 25 bar/0 ... 2500 kPa	125 bar/12500 kPa	0 bar abs.
0 ... 60 bar/0 ... 6000 kPa	200 bar/20000 kPa	0 bar abs.
0 ... 100 bar/0 ... +10000 kPa (only for measuring cell ø 28 mm)	200 bar/20000 kPa	0 bar abs.

Nominal measuring ranges and overload capacity in psi

Nominal range	Overload capability	
	Maximum pressure	Minimum pressure
Gauge pressure		
0 ... +0.4 psig (only for measuring cell ø 28 mm)	+75 psig	-0.7 psig
0 ... +1.5 psig	+225 psig	-3 psig
0 ... +5 psig	+375 psig	-11.50 psig
0 ... +15 psig	+525 psig	-14.51 psig

Switch-on phase

Run-up time with operating voltage U_B

- ≥ 12 V DC ≤ 9 s
- < 12 V DC ≤ 22 s

Output variable

Output signal digital output signal, Foundation Fieldbus protocol

Transmission rate 31.25 Kbit/s

Damping (63 % of the input variable) 0 ... 999 s, adjustable

Channel Numbers

- Channel 1 Process value
- Channel 8 Electronics temperature

Current value

- Non-Ex, Ex-ia and Ex-d instruments 12 mA, ± 0.5 mA

Dynamic behaviour output

Dynamic characteristics depending on medium and temperature

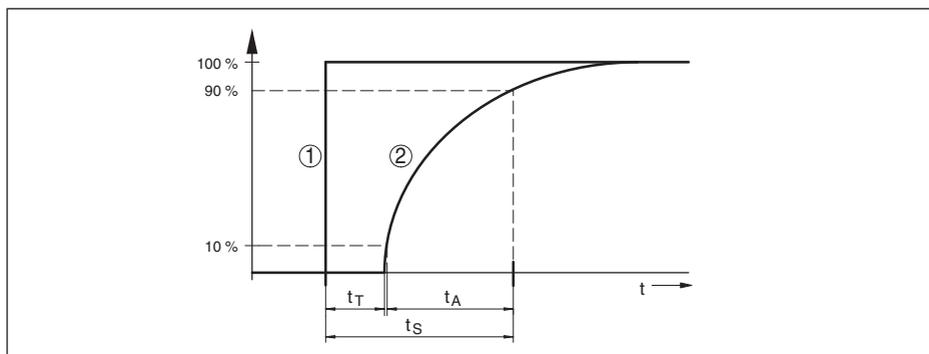

Fig. 38: Behaviour in case of sudden change of the process variable. t_T : dead time; t_A : rise time; t_S : jump response time

- 1 Process variable
- 2 Output signal

	CPT-2x	CPT-2x - IP 68 (25 bar)
Dead time	≤ 25 ms	≤ 50 ms
Rise time (10 ... 90 %)	≤ 55 ms	≤ 150 ms
Step response time (t_i : 0 s, 10 ... 90 %)	≤ 80 ms	≤ 200 ms

Damping (63 % of the input variable) 0 ... 999 s, adjustable via menu item "Damping"

Reference conditions and influencing variables (according to DIN EN 60770-1)

Reference conditions according to DIN EN 61298-1

- Temperature $+15 \dots +25$ °C ($+59 \dots +77$ °F)

– Relative humidity	45 ... 75 %
– Air pressure	860 ... 1060 mbar/86 ... 106 kPa (12.5 ... 15.4 psig)
Determination of characteristics	Limit point adjustment according to IEC 61298-2
Characteristic curve	Linear
Reference installation position	upright, diaphragm points downward
Influence of the installation position	< 0.2 mbar/20 Pa (0.003 psig)

Reference conditions and influencing variables (according to DIN EN 60770-1)

Reference conditions according to DIN EN 61298-1

– Temperature	+15 ... +25 °C (+59 ... +77 °F)
– Relative humidity	45 ... 75 %
– Air pressure	860 ... 1060 mbar/86 ... 106 kPa (12.5 ... 15.4 psig)
Determination of characteristics	Limit point adjustment according to IEC 61298-2
Characteristic curve	Linear
Reference installation position	upright, diaphragm points downward
Influence of the installation position	< 0.2 mbar/20 Pa (0.003 psig)

Deviation (according to IEC 60770-1)

Specifications refer to the set span. Turn down (TD) is the ratio: nominal measuring range/set span.

Accuracy class	Non-linearity, hysteresis and repeatability with TD 1 : 1 up to 5 : 1	Non-linearity, hysteresis and repeatability with 5 : 1
0.05 %	< 0.05 %	< 0.01 % x TD
0.1 %	< 0.1 %	< 0.02 % x TD
0.2 %	< 0.2 %	< 0.04 % x TD

Influence of the product temperature

Thermal change zero signal and output span through product temperature

Applies to the **digital** signal output (HART, Profibus PA, Foundation Fieldbus) as well as to the **analogue** current output 4 ... 20 mA and refers to the set span. Turn down (TD) is the ratio "nominal measuring range/set span".

The thermal change of the zero signal and output span corresponds to the temperature error F_T in chapter "*Calculation of the total deviation (according to DIN 16086)*".

Basic temperature error F_T

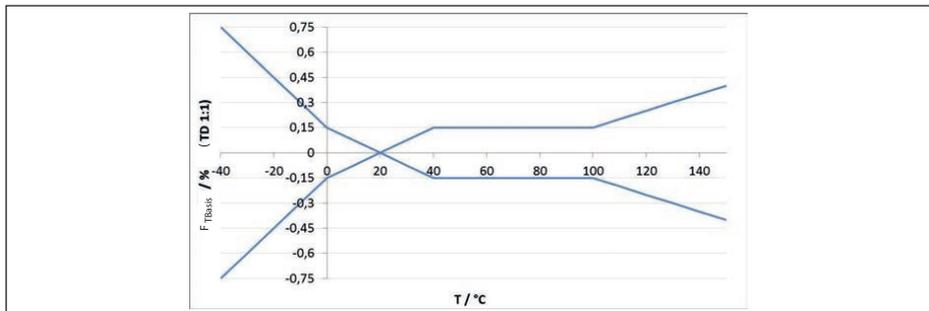

Fig. 39: Basic temperature error $F_{T_{Basis}}$ at TD 1 : 1

The basic temperature error in % from the above graphic can increase due to the additional factors, depending on the measuring cell version (factor FMZ) and the Turn Down (factor FTD). The additional factors are listed in the following tables.

Additional factor through measuring cell version

Measuring cell version	Measuring cell standard, depending on the accuracy class		
	0.05 %, 0.1 %	0.2 % (with measuring range 0.1 bar _{abs})	0.2 % 0.05 %, 0.1 % with measuring range 25 mbar
Factor FMZ	1	2	3

Measuring cell version	Measuring cell climate-compensated, depending on measuring range		
	-1 ... 0 bar, -1 ... 1,5 bar, 10 bar, 25 bar, 60 bar, 100 bar	-0.5 ... 0.5 bar, 1 bar, 2,5 bar	0.4 bar, -0.2 ... 0.2 bar
Factor FMZ	1	2	3

Additional factor through Turn Down

The additional factor FTD through Turn down is calculated according to the following formula:

$$F_{TD} = 0.5 \times TD + 0.5$$

In the table, example values for typical Turn downs are listed.

Turn Down	TD 1 : 1	TD 2.5 : 1	TD 5 : 1	TD 10 : 1	TD 20 : 1
Factor FTD	1	1.75	3	5.5	10.5

Long-term stability (according to DIN 16086)

Applies to the respective **digital** signal output (e.g. HART, Profibus PA) as well as to **analogue** current output 4 ... 20 mA under reference conditions. Specifications refer to the set span. Turn down (TD) is the ratio nominal measuring range/set span.

Time period	Measuring cell ø 28 mm		Measuring cell ø 17.5 mm	
	All measuring ranges	Measuring range 0 ... +0.025 bar (0 ... +2.5 kPa)	All process fittings	Process fitting G $\frac{1}{2}$ (ISO 228-1)
One year	< 0.05 % x TD	< 0.1 % x TD	< 0.1 % x TD	< 0.25 % x TD
Five years	< 0.1 % x TD	< 0.2 % x TD	< 0.2 % x TD	< 0.5 % x TD
Ten years	< 0.2 % x TD	< 0.4 % x TD	< 0.4 % x TD	< 1 % x TD

Ambient conditions

Version	Ambient temperature	Storage and transport temperature
Standard version	-40 ... +80 °C (-40 ... +176 °F)	-60 ... +80 °C (-76 ... +176 °F)
Version IP 66/IP 68 (1 bar)	-20 ... +80 °C (-4 ... +176 °F)	-20 ... +80 °C (-4 ... +176 °F)
Version IP 68 (25 bar) with connection cable PUR	-20 ... +80 °C (-4 ... +176 °F)	-20 ... +80 °C (-4 ... +176 °F)
Version IP 68 (25 bar), connection cable PE	-20 ... +60 °C (-4 ... +140 °F)	-20 ... +60 °C (-4 ... +140 °F)

Process conditions

Process temperature⁵⁾

Measuring cell seal		Sensor version	
		Standard	Extended temperature range ⁶⁾
FKM	VP2/A	-20 ... +130 °C (-4 ... +266 °F)	-20 ... +150 °C (-4 ... +302 °F)
	A+P 70.16	-40 ... +130 °C (-40 ... +266 °F)	-
	Endura V91A	-40 ... +130 °C (-40 ... +266 °F)	-40 ... +150 °C (-40 ... +302 °F)
	ET 7067	-20 ... +130 °C (-4 ... +266 °F)	-
	V70SW	-	-10 ... +150 °C (14 ... +302 °F)
EPDM	A+P 70.10-02	-40 ... +130 °C (-40 ... +266 °F)	-40 ... +150 °C (-40 ... +302 °F)
	ET 7056	-40 ... +130 °C (-40 ... +266 °F)	-
	E70Q	-	-40 ... +150 °C (-40 ... +302 °F)
	Fluoraz SD890	-5 ... +130 °C (-22 ... +266 °F)	-
FFKM	Kalrez 6375	-20 ... +130 °C (-4 ... +266 °F)	-20 ... +150 °C (-4 ... +302 °F)
	Perlast G75S	-15 ... +130 °C (-4 ... +266 °F)	-15 ... +150 °C (5 ... +302 °F)
	Perlast G75B	-15 ... +130 °C (-4 ... +266 °F)	-15 ... +150 °C (5 ... +302 °F)
	Perlast G92E	-15 ... +130 °C (-4 ... +266 °F)	-15 ... +150 °C (5 ... +302 °F)
	Chemraz 535	-30 ... +130 °C (-22 ... +266 °F)	-

Temperature derating

⁵⁾ With process fitting PVDF, process temperature max. 100 °C (212 °F).

⁶⁾ Measuring cell ø 28 mm

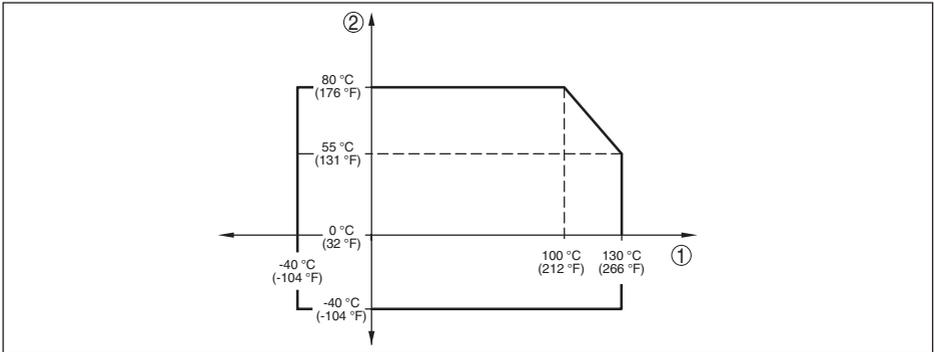

Fig. 40: Temperature derating CPT-2x, version up to +130 °C (+266 °F)

- 1 Process temperature
- 2 Ambient temperature

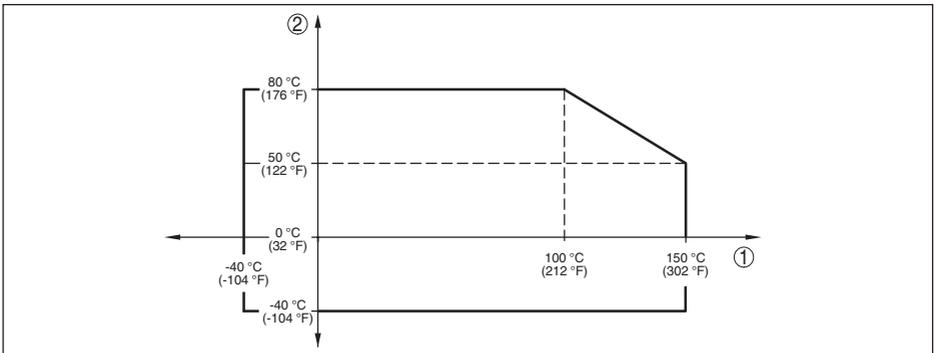

Fig. 41: Temperature derating CPT-2x, version up to +150 °C (+302 °F)

- 1 Process temperature
- 2 Ambient temperature

SIP process temperature (SIP = Sterilization in place)

Applies to instruments configurations suitable for vapour, i.e. material measuring cell seal EPDM or FFKM (Perlast G75S).

Vapour stratification up to 2 h +150 °C (+302 °F)

Process pressure

Permissible process pressure see specification "process pressure" on the type label

Mechanical stress⁷⁾

Vibration resistance 4 g at 5 ... 200 Hz according to EN 60068-2-6 (vibration with resonance)

Shock resistance 50 g, 2.3 ms according to EN 60068-2-27 (mechanical shock)⁸⁾

⁷⁾ Depending on the instrument version.

⁸⁾ 2 g with housing version stainless steel double chamber

Electromechanical data - version IP 66/IP 67 and IP 66/IP 68 (0.2 bar)⁹⁾

Options of the cable entry

- Cable entry M20 x 1.5; ½ NPT
- Cable gland M20 x 1.5, ½ NPT (cable ø see below table)
- Blind plug M20 x 1.5; ½ NPT
- Closing cap ½ NPT

Material cable gland/Seal insert	Cable diameter			
	5 ... 9 mm	6 ... 12 mm	7 ... 12 mm	10 ... 14 mm
PA/NBR	●	●	-	●
Brass, nickel-plated/NBR	●	●	-	-
Stainless steel/NBR	-	-	●	-

Wire cross-section (spring-loaded terminals)

- Massive wire, stranded wire 0.2 ... 2.5 mm² (AWG 24 ... 14)
- Stranded wire with end sleeve 0.2 ... 1.5 mm² (AWG 24 ... 16)

Electromechanical data - version IP 66/IP 68 (1 bar)

Connection cable, mechanical data

- Configuration Wires, breather capillaries, strain relief, screen braiding, metal foil, mantle
- Standard length 5 m (16.4 ft)
- Min. bending radius 25 mm (0.984 in) with 25 °C (77 °F)
- Diameter approx. 8 mm (0.315 in)
- Colour - version PE Black
- Colour - version PUR Blue

Connection cable, electrical data

- Wire cross-section 0.5 mm² (AWG 20)
- Wire resistance R' 0.037 Ω/m (0.012 Ω/ft)

Display and adjustment module

Display element Display with backlight

Measured value indication

- Number of digits 5

Adjustment elements

- 4 keys **[OK], [->], [+], [ESC]**

Protection rating

- unassembled IP 20
- Mounted in the housing without lid IP 40

Materials

- Housing ABS

⁹⁾ IP 66/IP 68 (0.2 bar), only with absolute pressure.

– Inspection window	Polyester foil
Functional safety	SIL non-reactive

Interface to the external display and adjustment unit

Data transmission	Digital (I ² C-Bus)
Connection cable	Four-wire

Sensor version	Configuration, connection cable		
	Cable length	Standard cable	Screened
4 ... 20 mA/HART Modbus	50 m	●	–
Profibus PA, Foundation Fieldbus	25 m	–	●

Integrated clock

Date format	Day.Month.Year
Time format	12 h/24 h
Time zone, factory setting	CET
Max. rate deviation	10.5 min/year

Additional output parameter - Electronics temperature

Range	-40 ... +85 °C (-40 ... +185 °F)
Resolution	< 0.1 K
Deviation	±3 K
Output of the temperature values	
– Indication	Via the display and adjustment module
– Analogue	Via the current output, the additional current output
– Digital	Via the digital output signal (depending on the electronics version)

Voltage supply

Operating voltage U_B	
– Non-Ex instrument	9 ... 32 V DC
– Ex-d instrument	9 ... 32 V DC
– Ex-ia instrument - Power supply FISCO model	9 ... 17.5 V DC
– Ex-ia instrument - Power supply ENTITY model	9 ... 24 V DC
Operating voltage U_B with lighting switched on	
– Non-Ex instrument	13.5 ... 32 V DC
– Ex-d instrument	13.5 ... 32 V DC
– Ex-ia instrument - Power supply FISCO model	13.5 ... 17.5 V DC

– Ex-ia instrument - Power supply ENTITY model 13.5 ... 24 V DC

Power supply by/max. number of sensors

– Fieldbus max. 32 (max. 10 with Ex)

Potential connections and electrical separating measures in the instrument

Electronics	Not non-floating
Reference voltage ¹⁰⁾	500 V AC
Conductive connection	Between ground terminal and metallic process fitting

Electrical protective measures¹¹⁾

Housing material	Version	Protection acc. to IEC 60529	Protection acc. to NEMA
Plastic	Single chamber	IP 66/IP 67	Type 4X
	Double chamber		
Aluminium	Single chamber	IP 66/IP 67 IP 66/IP 68 (0.2 bar) IP 68 (1 bar)	Type 4X Type 6P -
	Double chamber	IP 66/IP 67 IP 66/IP 68 (0.2 bar)	Type 4X Type 6P
Stainless steel (electro-polished)	Single chamber	IP 66/IP 67 IP 69K	Type 4X
Stainless steel (precision casting)	Single chamber	IP 66/IP 67 IP 66/IP 68 (0.2 bar) IP 68 (1 bar)	Type 4X Type 6P -
	Double chamber	IP 66/IP 67 IP 66/IP 68 (0.2 bar)	Type 4X Type 6P
Stainless steel	Transmitter, version with external housing	IP 68 (25 bar)	-

Connection of the feeding power supply unit Networks of overvoltage category III

Altitude above sea level

– by default up to 2000 m (6562 ft)

– with connected overvoltage protection up to 5000 m (16404 ft)

Pollution degree¹²⁾ 2

Protection rating (IEC/EN 61010-1) II

Approvals

Instruments with approvals can have deviating technical data (depending on the version). For such instruments, the corresponding approval documents must be noted.

¹⁰⁾ Galvanic separation between electronics and metal housing parts

¹¹⁾ Protection rating IP 66/IP 68 (0.2 bar) only in conjunction with absolute pressure.

¹²⁾ When used with fulfilled housing protection.

10.2 Supplementary information Foundation Fieldbus

The following table gives you an overview of the instrument versions and the corresponding device descriptions, the electrical characteristics of the bus system as well as the applied function blocks.

Revisions Data	DD-Revision	Rev_01
	CFF-File	020101.cff
	Device Revision	0101.ff0, 0101.ff5
	Cff-Revision	xx xx 01
	Device software revision	> 1.1.0
	ITK (Interoperability Test Kit) Number	6.2.0
Electrical Characteristics	Physical Layer Type	Low-power signaling, bus-powered, FISCO I.S.
	Input Impedance	> 3000 Ohms between 7.8 KHz - 39 KHz
	Unbalanced Capacitance	< 250 pF to ground from either input terminal
	Output Amplitude	0.8 V P-P
	Electrical Connection	2 Wire
	Polarity Insensitive	Yes
	Max. Current Load	11 mA
	Device minimum operating voltage	9 V
Transmitter Function Blocks	Resource Block (RB)	1
	Transducer Block (TB)	1
	Standard Block (AI)	3
	Execution Time	30 mS
Advanced Function Blocks	Discret Input (DI)	Yes
	PID Control	Yes
	Output Splitter (OS)	Yes
	Signal Characterizer (SC)	Yes
	Integrator	Yes
	Input Selector (IS)	Yes
	Arithmetic (AR)	Yes
Diagnostics	Standard	Yes
	Advanced	Yes
	Performance	No
	Function Blocks Instantiable	No
General Information	LAS (Link Active Scheduler)	Yes
	Master Capable	Yes
	Number of VCRs (Virtual Communication Relationships)	47

Function blocks

Transducer Block (TB)

The Transducer Block "Analog Input (AI)" takes the original measured value (Secondary Value 2), carries out the min./max. adjustment (Secondary Value 1), carries out a linearization (Primary Value) and makes the values on its output available for further function blocks.

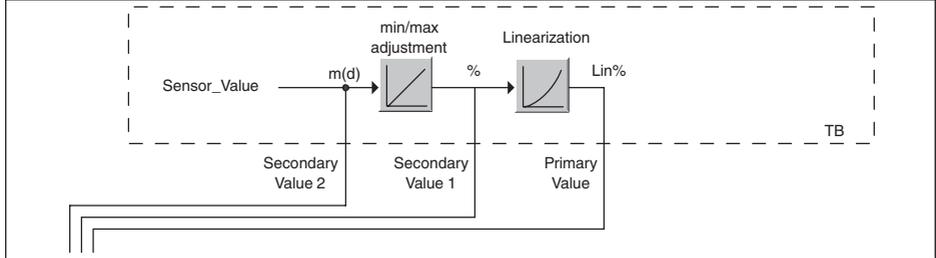

Fig. 42: Schematic presentation Transducer Block (TB)

Function block Analog Input (AI)

The function block "Analog Input (AI)" takes the original measured value selected by a Channel Number and makes it available to additional function blocks on its output.

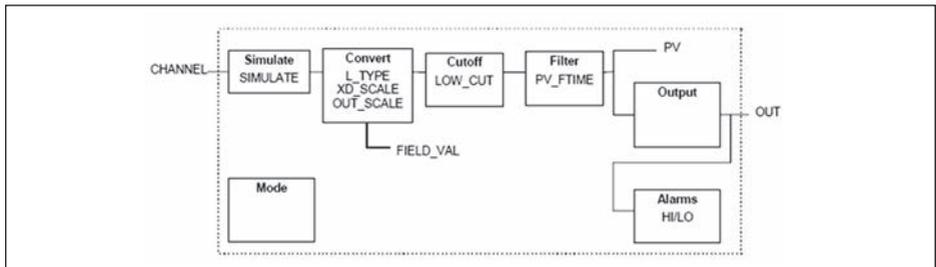

Fig. 43: Schematic presentation function block Analog Input (AI)

Function block Discret Input (DI)

The function block "Discret Input (DI)" takes the original measured value selected by a Channel Number and makes it available to additional function blocks on its output.

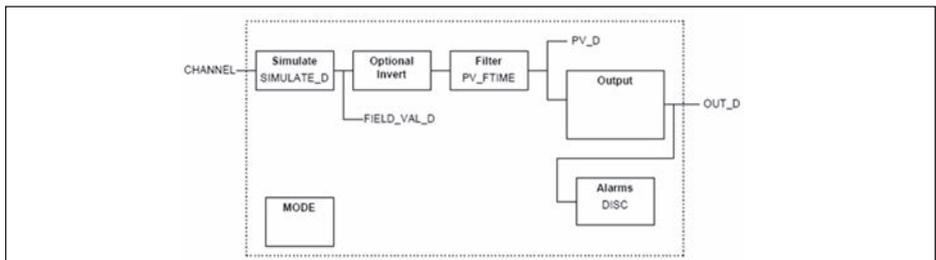

Fig. 44: Schematic presentation function block Discret Input (DI)

Function block PID Control

The function block "PID Control" is a key component for various tasks in the process automation

and is used universally. PID blocks can be cascaded if this is necessary or requested due to different time constants with the primary and secondary process measurement.

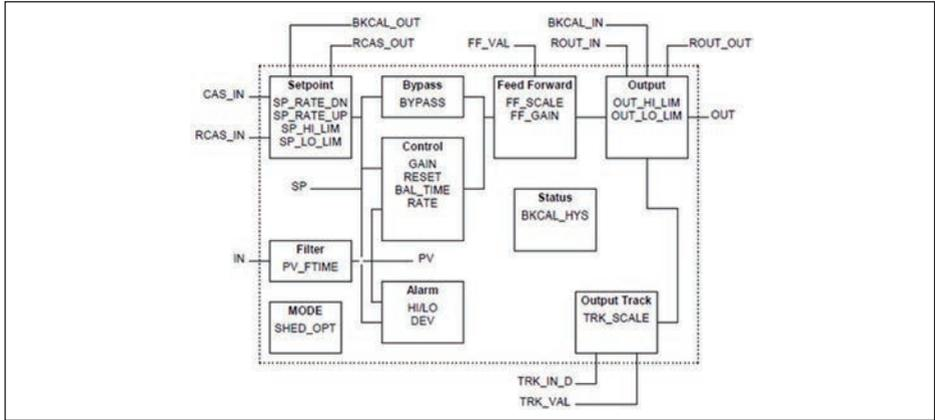

Fig. 45: Schematic presentation function block PID Control

Function block Output Splitter

The function block "Output Splitter" generates two control outputs out of one input. Each output is a linear image of a part of the input. A retrograde calculation function is realised by using the linear imaging function inversely. A cascading of several Output Splitters is supported by an integrated decision table for the combinability of inputs and outputs.

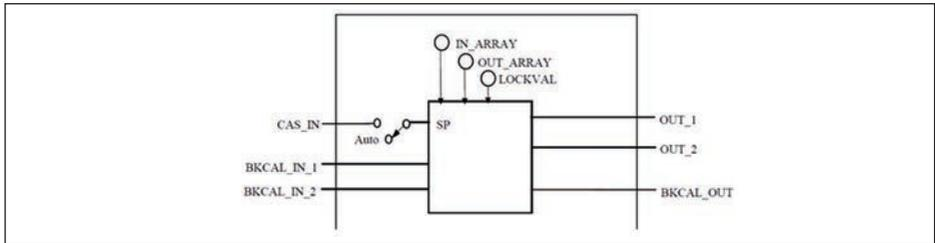

Fig. 46: Schematic presentation function block Output Splitter

Function block Signal Characterizer

The function block "Signal Characterizer" has two channels the outputs of which are not in linear relation with the respective input. The non-linear relation is defined by a look-up table with individually selectable x/y-pairs. The respective input signal is imaged on the corresponding output, hence this function block can be used in a control loop or signal path. Optionally the function axis can be exchanged in channel 2 so that the block can be also used in a reverse control loop.

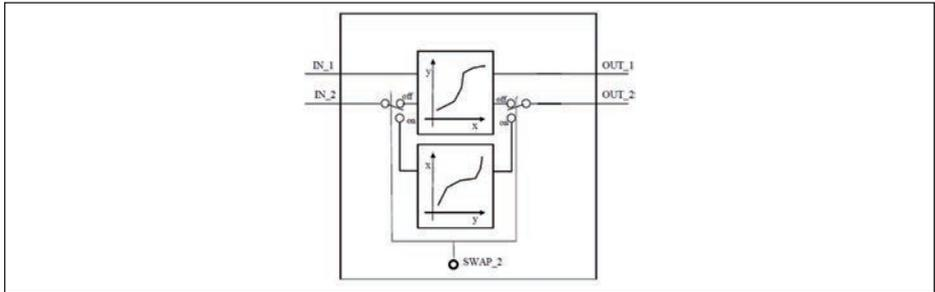

Fig. 47: Schematic presentation function block Signal Characterizer

Function block Integrator

The function block "Integrator" integrates a continuous input signal over the time and sums the results of an impulse input block. It is used as a totalizer up to a reset or as a subtotalizer up to a reference point at which the integrated and accumulated value is compared with the default values. When these default values are reached, digital output signals will be outputted. The integration function is carried out upwardly starting with zero and downwards with a default value. Two flow values are also available so that the net flow volume can be calculated and integrated. This can be used for calculation of volume and mass changes in the vessel or for optimisation of flow controls.

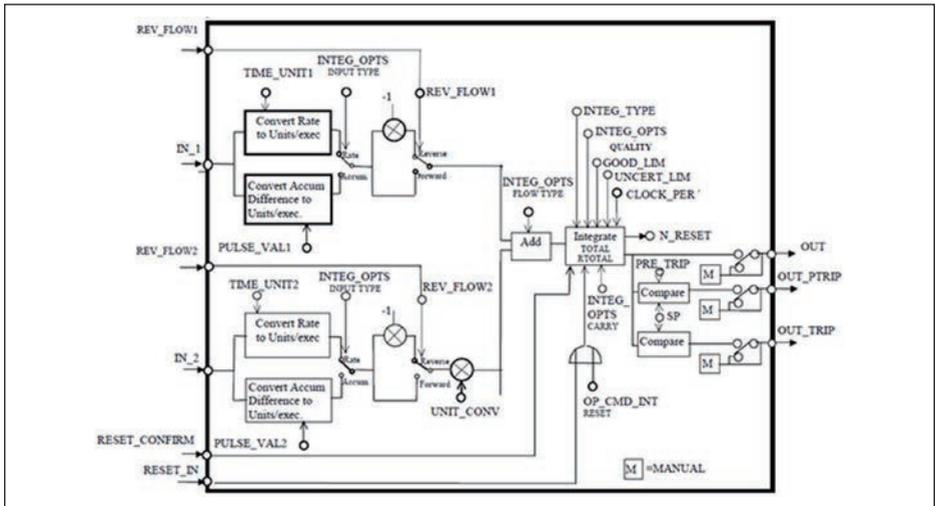

Fig. 48: Schematic presentation function block Integrator

Function block Input Selector

The function block "Input Selector" offers selection possibilities for up to four inputs and generates an output signal according to the selection criteria. Typical input signals are AI blocks. Selection possibilities are maximum, minimum, mean value, average value and first useful signal. Through parameter combination, the block can be used as rotary switch or as preselection switch for the first useful value. Switch information can be received by other input blocks or the user. Mean value selection is also supported.

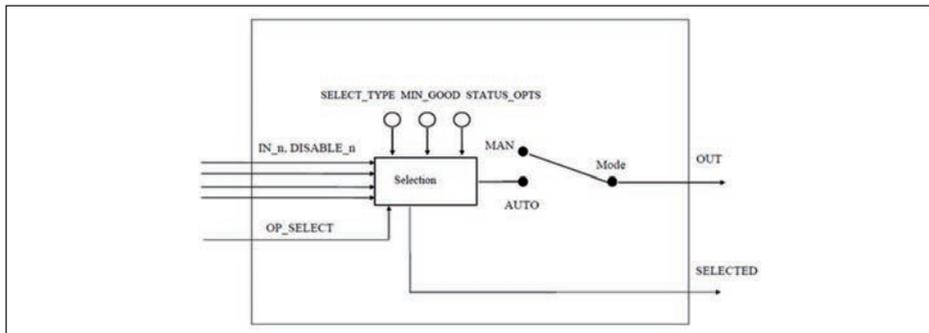

Fig. 49: Schematic presentation function block Input Selector

Function block Arithmetic

The function block "Arithmetic" allows the simple integration of usual metrological calculation functions. The user can select the requested measurement algorithm according to the name without knowing the formula.

The following algorithms are available:

- Flow compensation, linear
- Flow compensation, square root
- Flow compensation, approximate
- BTU flow
- Traditional Multiply Divide
- Average
- Traditional Summer
- Fourth order polynomial
- Simple HTG compensated level
- Fourth order Polynomial Based on PV

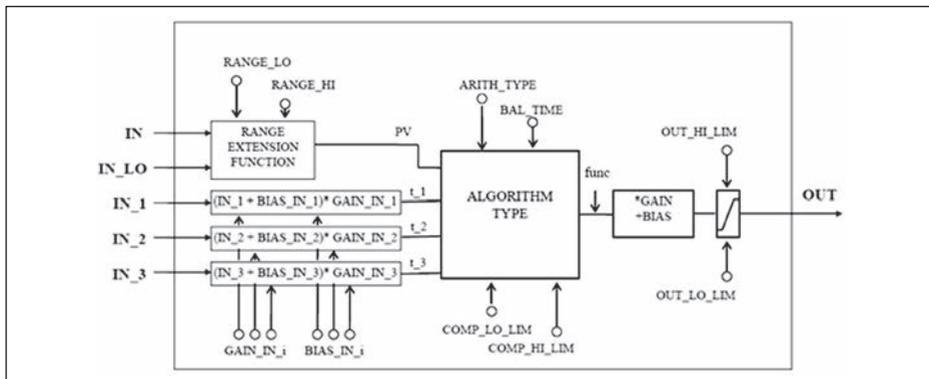

Fig. 50: Schematic presentation function block Arithmetic

10.3 Calculation of the total deviation

The total deviation of a pressure transmitter indicates the maximum measurement error to be expected in practice. It is also called maximum practical deviation or operational error.

According to DIN 16086, the total deviation F_{total} is the sum of the basic deviation F_{perf} and the long-term stability F_{stab} :

$$F_{\text{total}} = F_{\text{perf}} + F_{\text{stab}}$$

The basic deviation F_{perf} consists of the thermal change of the zero signal and the output span F_T as well as the deviation F_{Kl} :

$$F_{\text{perf}} = \sqrt{(F_T)^2 + (F_{Kl})^2}$$

The thermal change of zero signal and output span F_T is specified in chapter "*Technical data*". The basic temperature error F_T is shown in a graphic. Depending on the measuring cell version and Turn down, this value must be multiplied with the additional factors FMZ and FTD:

$$F_T \times \text{FMZ} \times \text{FTD}$$

Also these values are specified in chapter "*Technical data*".

This applies for a digital signal output through HART, Profibus PA or Foundation Fieldbus.

With a 4 ... 20 mA output, the thermal change of the current output F_a must be added:

$$F_{\text{perf}} = \sqrt{((F_T)^2 + (F_{Kl})^2 + (F_a)^2)}$$

To provide a better overview, the formula symbols are listed together below:

- F_{total} : Total deviation
- F_{perf} : Basic deviation
- F_{stab} : Long-term stability
- F_T : Thermal change of zero signal and output span (temperature error)
- F_{Kl} : Deviation
- F_a : Thermal change of the current output
- FMZ: Additional factor measuring cell version
- FTD: Additional factor Turn down

10.4 Practical example

Data

Pressure measurement in the pipeline 4 bar (400 KPa)

Product temperature up to 50 °C

CPT-2x with measuring range 10 bar, deviation < 0.2 %, process fitting G1½ (measuring cell ø 28 mm)

1. Calculation of the Turn down

$$\text{TD} = 10 \text{ bar} / 4 \text{ bar}, \text{TD} = \mathbf{2.5 : 1}$$

2. Determination temperature error F_T

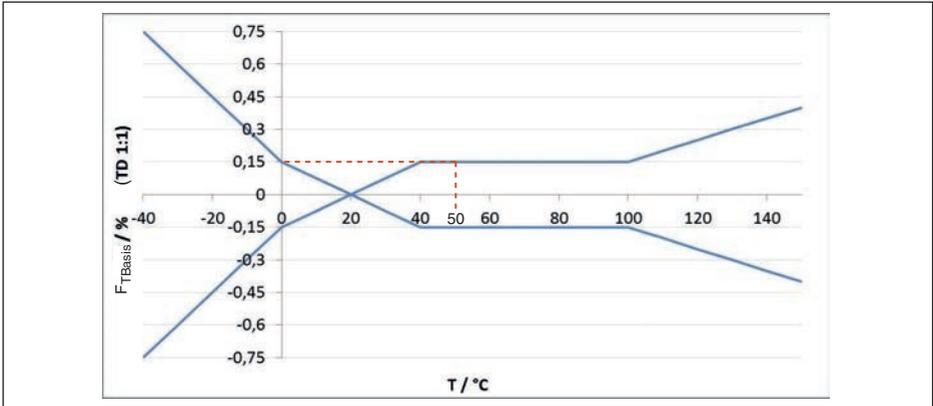

Fig. 51: Determination of the basic temperature error for the above example: $F_{TBasis} = 0.15\%$

Measuring cell version	Measuring cell standard, depending on the accuracy class		
	0.05 %, 0.1 %	0.2 % (0.1 bar _{abs})	0.2 %
Factor FMZ	1	2	3

Tab. 22: Determination of the additional factor measuring cell for above example: $F_{MZ} = 3$

Turn Down	TD 1 : 1	TD 2.5 : 1	TD 5 : 1	TD 10 : 1	TD 20 : 1
Factor FTD	1	1.75	3	5.5	10.5

Tab. 23: Determination of the additional factor "turn down" for the above example: $F_{TD} = 1.75$

$$F_T = F_{TBasis} \times F_{MZ} \times F_{TD}$$

$$F_T = 0.15\% \times 3 \times 1.75$$

$$F_T = 0.79\%$$

3. Determination of deviation and long-term stability

The required values for deviation F_{KI} and long-term stability F_{stab} are available in the technical data:

Accuracy class	Non-linearity, hysteresis and non-repeatability	
	TD ≤ 5 : 1	TD > 5 : 1
0.05 %	< 0.05 %	< 0.01 % x TD
0.1 %	< 0.1 %	< 0.02 % x TD
0.2 %	< 0.2 %	< 0.04 % x TD

Tab. 24: Determination of the deviation from table: $F_{KI} = 0.2\%$

Time period	Measuring cell ø 28 mm		Measuring cell ø 17.5 mm	
	All measuring ranges	Measuring range 0 ... +0.025 bar (0 ... +2.5 kPa)	All process fittings	Process fitting G½ (ISO 228-1)
One year	< 0.05 % x TD	< 0.1 % x TD	< 0.1 % x TD	< 0.25 % x TD
Five years	< 0.1 % x TD	< 0.2 % x TD	< 0.2 % x TD	< 0.5 % x TD
Ten years	< 0.2 % x TD	< 0.4 % x TD	< 0.4 % x TD	< 1 % x TD

Tab. 25: Determination of the long-term stability from the table, consideration for one year: $F_{stab} = 0.05 \% \times TD$

4. Calculation of the total deviation - digital signal outputs

1. step: Basic deviation F_{perf}

$$F_{perf} = \sqrt{((F_T)^2 + (F_{KI})^2)}$$

$$F_T = 0.79 \%$$

$$F_{KI} = 0.2 \%$$

$$F_{perf} = \sqrt{(0.79 \%)^2 + (0.2 \%)^2}$$

$$F_{perf} = 0.81 \%$$

2. step: Total deviation F_{total}

$$F_{total} = F_{perf} + F_{stab}$$

$$F_{perf} = 0.81 \% \text{ (result of step 1)}$$

$$F_{stab} = (0.05 \% \times TD)$$

$$F_{stab} = (0.05 \% \times 2.5)$$

$$F_{stab} = 0.125 \%$$

$$F_{total} = 0.81 \% + 0.125 \% = 0.94 \%$$

The example shows that the measurement error in practice can be considerably higher than the basic deviation. Reasons are temperature influence and Turn down.

10.5 Dimensions

Plastic housing

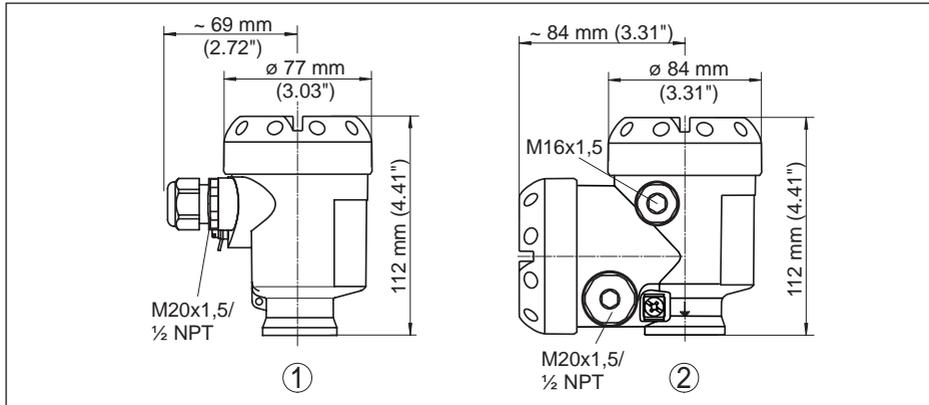

Fig. 52: Housing versions in protection IP 66/IP 67 (with integrated display and adjustment module the housing is 9 mm/0.35 in higher)

- 1 Plastic single chamber
- 2 Plastic double chamber

Aluminium housing

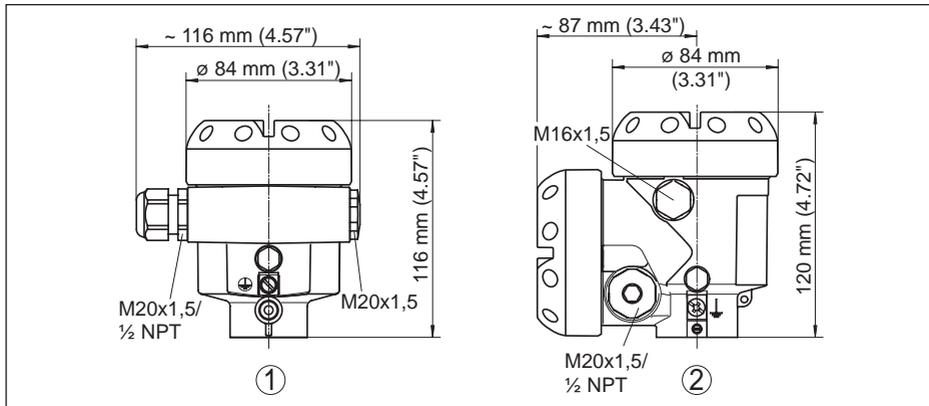

Fig. 53: Housing versions in protection IP 66/IP 67 (with integrated display and adjustment module the housing is 9 mm/0.35 in higher)

- 1 Aluminium - single chamber
- 2 Aluminium - double chamber

Aluminium housing with protection rating IP 66/IP 68 (1 bar)

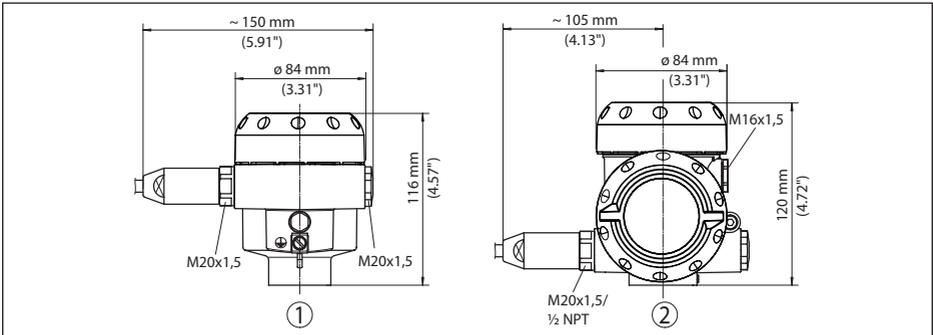

Fig. 54: Housing version with protection rating IP 66/IP 68 (1 bar), (with integrated display and adjustment module the housing is 9 mm/0.35 in higher)

- 1 Aluminium - single chamber
- 2 Aluminium - double chamber

Stainless steel housing

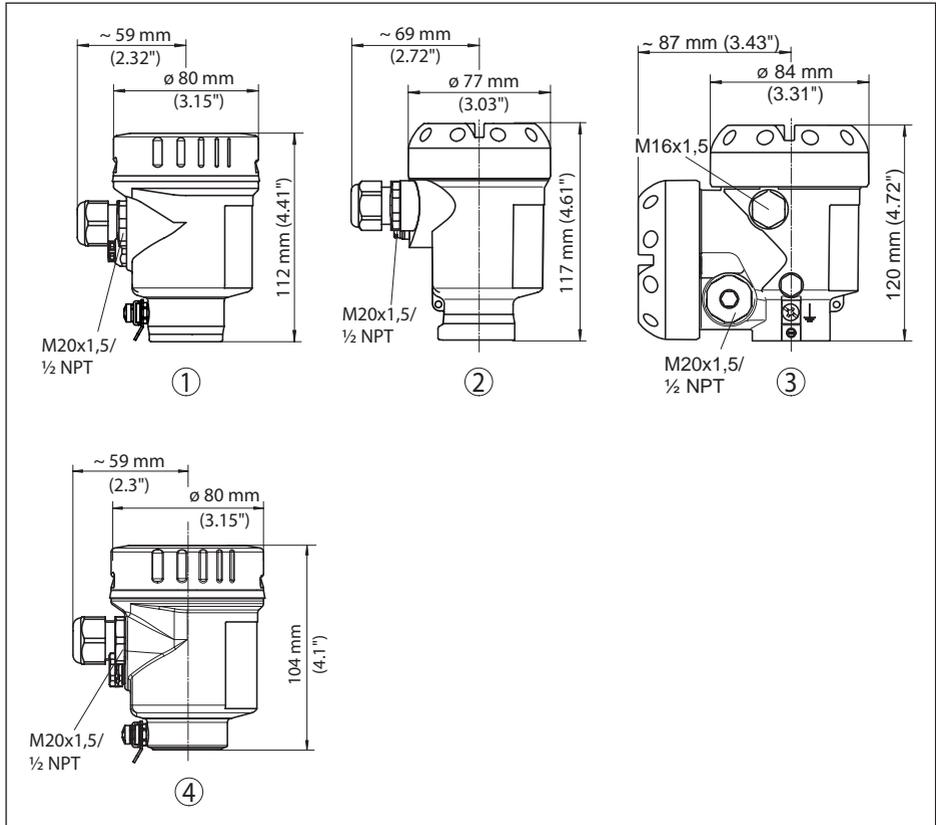

Fig. 55: Housing versions in protection IP 66/IP 67 (with integrated display and adjustment module the housing is 9 mm/0.35 in higher)

- 1 Stainless steel single chamber (electropolished)
- 2 Stainless steel single chamber (precision casting)
- 3 Stainless steel double chamber housing (precision casting)

Stainless steel housing with protection rating IP 66/IP 68 (1 bar)

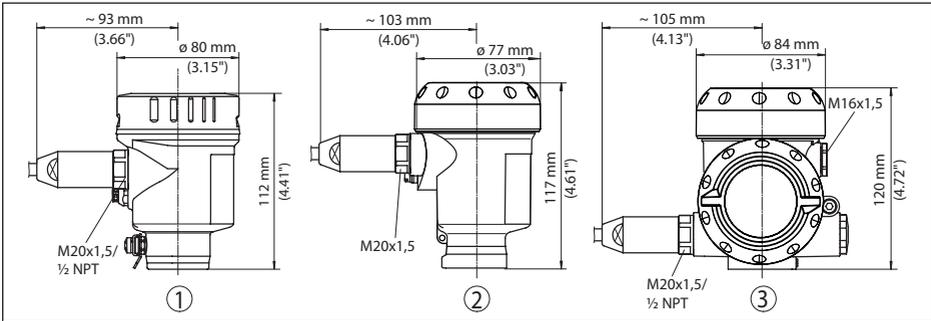

Fig. 56: Housing version with protection rating IP 66/IP 68 (1 bar), (with integrated display and adjustment module the housing is 9 mm/0.35 in higher)

- 1 Stainless steel single chamber (electropolished)
- 2 Stainless steel single chamber (precision casting)
- 3 Stainless steel double chamber housing (precision casting)

Stainless steel housing with protection rating IP 69K

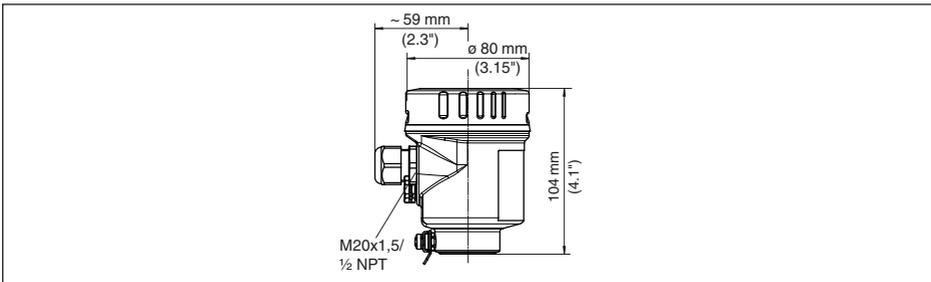

Fig. 57: Housing version with protection rating IP 69K (with integrated display and adjustment module the housing is 9 mm/0.35 in higher)

- 1 Stainless steel single chamber (electropolished)

External housing with IP 68 (25 bar) version

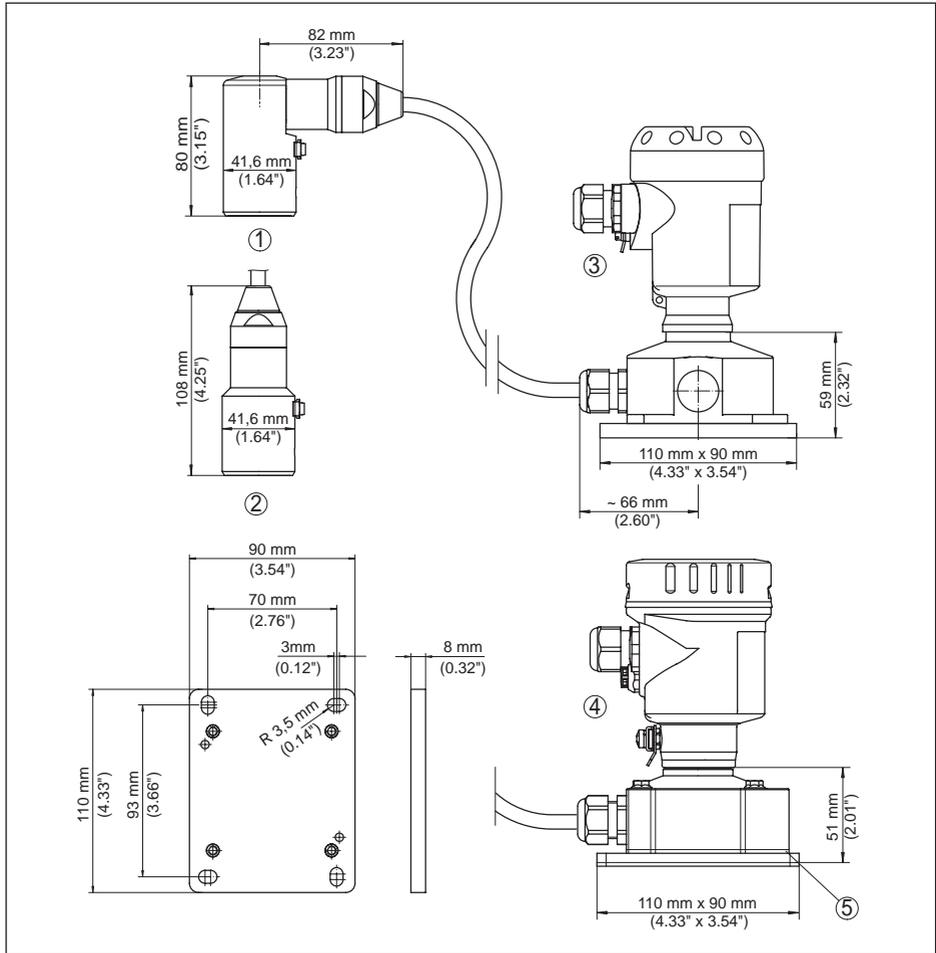

Fig. 58: IP 68 version with external housing

- 1 Lateral cable outlet
- 2 Axial cable outlet
- 3 Plastic housing
- 4 Stainless steel housing, electropolished

CPT-2x, threaded fitting not front-flush

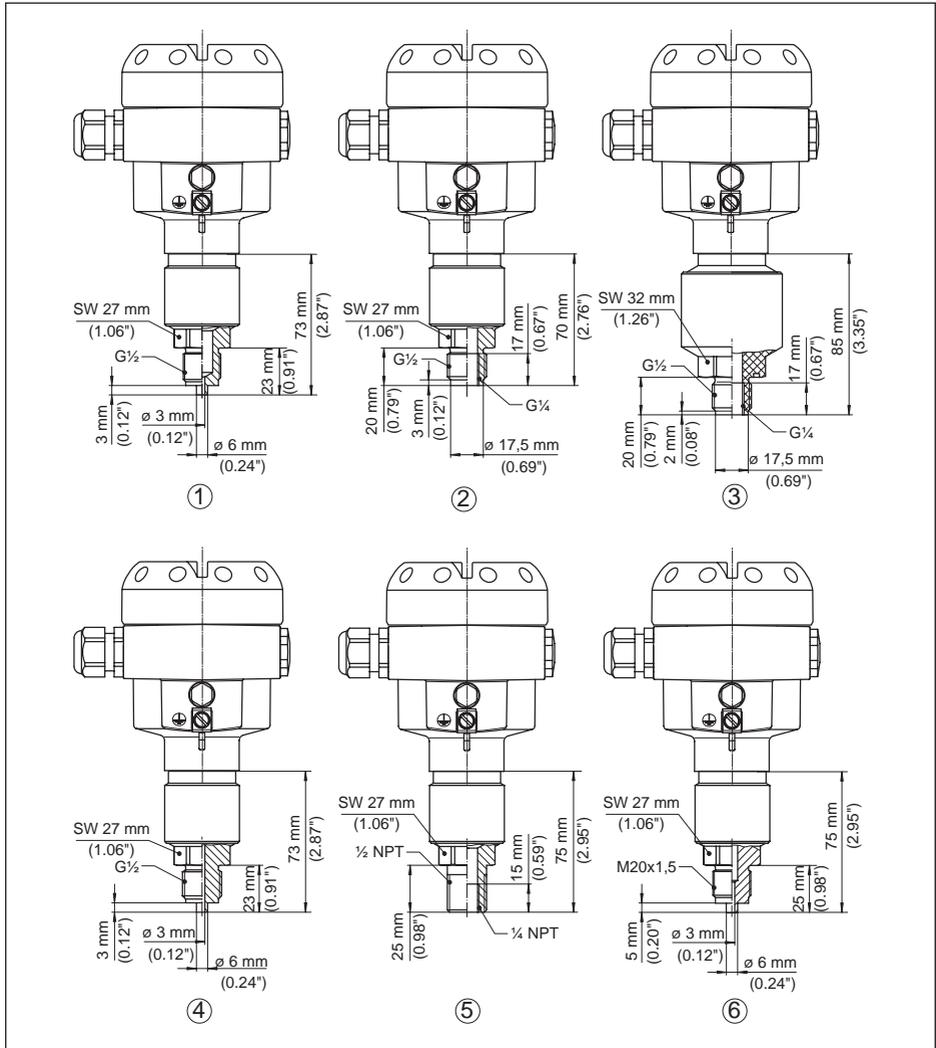

Fig. 59: CPT-2x, threaded fitting not front-flush

- 1 $G\frac{1}{2}$ manometer connection (EN 837)
- 2 $G\frac{1}{2}$ A inside $G\frac{1}{4}$ (ISO 228-1)
- 3 $G\frac{1}{2}$ A inside $G\frac{1}{4}$ A PVDF (ISO 228-1)
- 4 $G\frac{1}{2}$ manometer connection (EN 837) volume-reduced
- 5 $\frac{1}{2}$ NPT inside $\frac{1}{4}$ NPT
- 6 M20 x 1.5 manometer connection (EN 837)

Notes:

For the version with "Second Line of Defense", the measure of length increases by 17 mm (0.67 in).

CPT-2x, threaded fitting front-flush

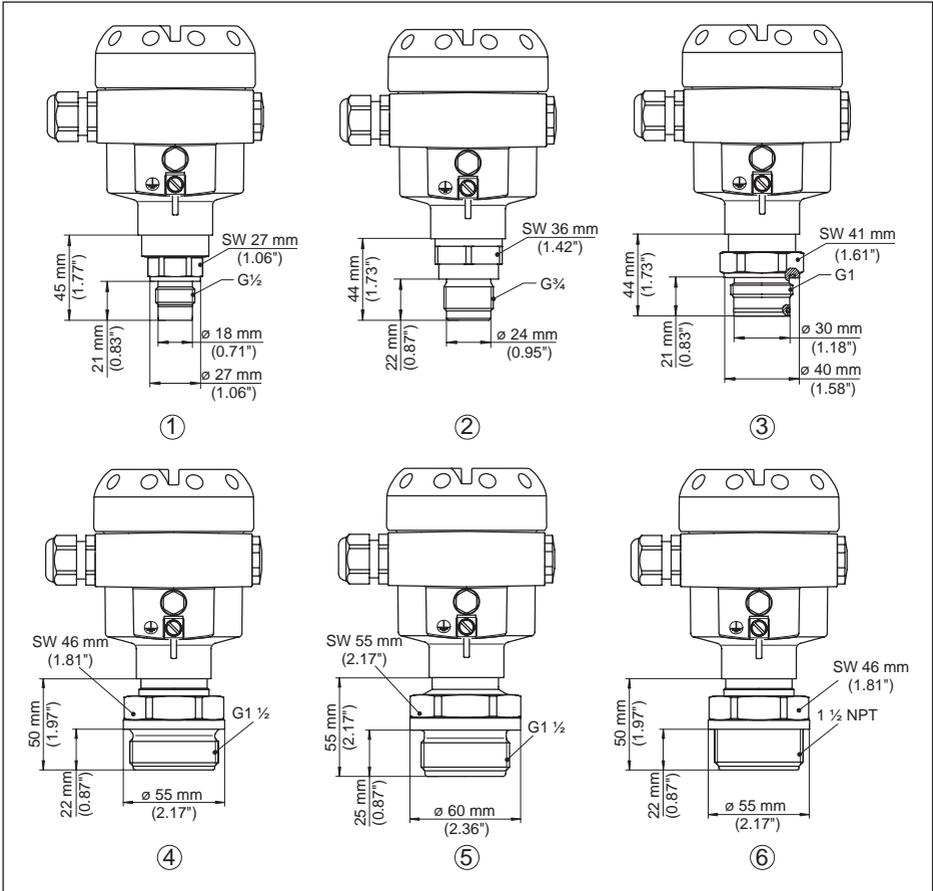

Fig. 60: CPT-2x, threaded fitting front-flush

- 1 G $\frac{1}{2}$ (ISO 228-1)
- 2 G $\frac{3}{4}$ (DIN 3852-E)
- 3 G1 A (ISO 228-1)
- 4 G1 $\frac{1}{2}$ (DIN 3852-A)
- 5 G1 $\frac{1}{2}$ A PVDF (DIN 3852-A-B)
- 6 1 $\frac{1}{2}$ NPT (ASME B1.20.1)

For the version with temperature range up to 150 °C/302 °F, the measure of length increases by 28 mm (1.1 in).

For the version with "Second Line of Defense", the measure of length increases by 17 mm (0.67 in).

CPT-2x, hygienic fitting

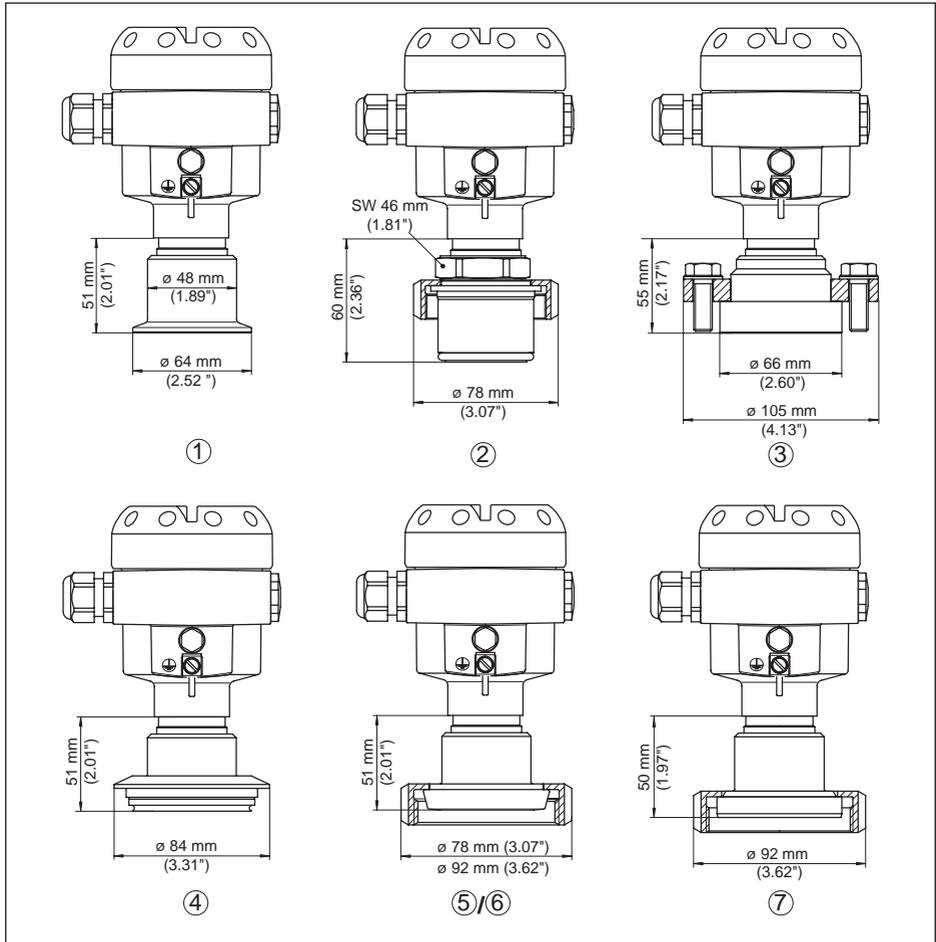

Fig. 61: CPT-2x, hygienic fitting

- 1 Clamp 2"
- 2 Hygienic connection with compression nut F40
- 3 DRD
- 4 Tuchenhagen Varivent DN 32
- 5 Slotted nut DN 40 according to DIN 11851
- 6 Slotted nut DN 50 according to DIN 11851
- 7 Slotted nut DN 50 according to DIN 11864-1

For the version with temperature range up to 150 °C/302 °F, the measure of length increases by 28 mm (1.1 in).

For the version with "Second Line of Defense", the measure of length increases by 17 mm (0.67 in).

CPT-2x, flange connection

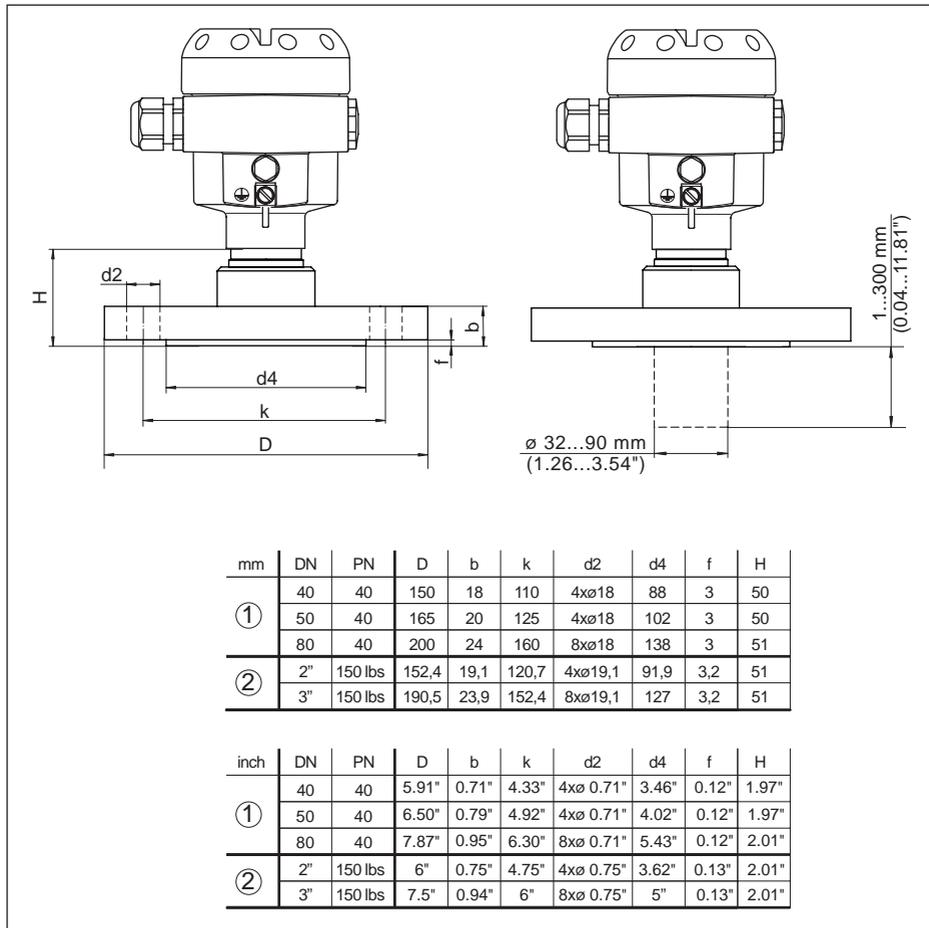

Fig. 62: CPT-2x, flange connection

- 1 Flange connection according to DIN 2501
- 2 Flange connection according to ASME B16.5

For the version with temperature range up to 150 °C/302 °F, the measure of length increases by 28 mm (1.1 in).

For the version with "Second Line of Defense", the measure of length increases by 17 mm (0.67 in).

CPT-2x, extension fitting

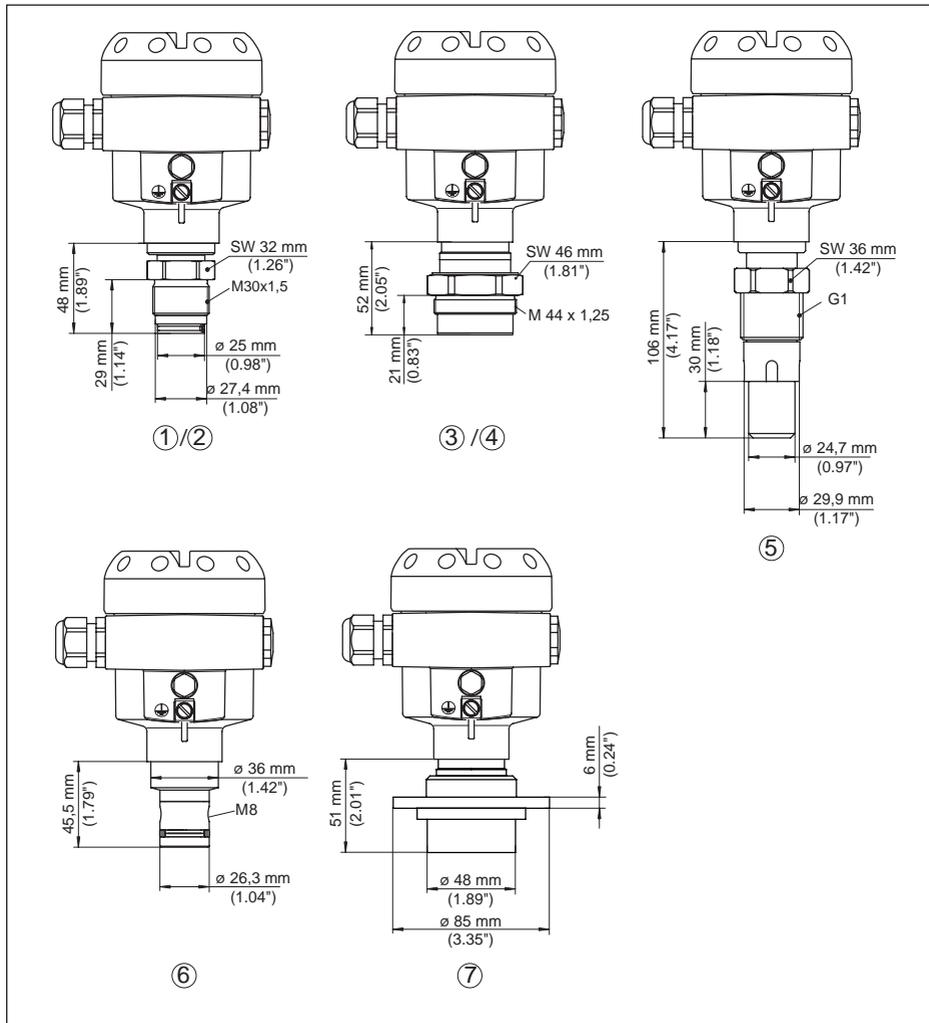

Fig. 63: CPT-2x, extension fitting

- 1 M30 x 1.5 DIN 13; completely front-flush
- 2 M30 x 1.5 DIN 13; for headbox
- 3 M44 x 1.25 DIN 13; pressure screw: Aluminium
- 4 M44 x 1.25 DIN 13; pressure screw: 316L
- 5 G1, ISO 228-1 suitable for PASVE
- 6 PMC 1" front-flush PN 6
- 7 DN 48 with tension flange

For the version with temperature range up to 150 °C/302 °F, the measure of length increases by 28 mm (1.1 in).

For the version with "Second Line of Defense", the measure of length increases by 17 mm (0.67 in).

CPT-2x, connection acc. to IEC 61518

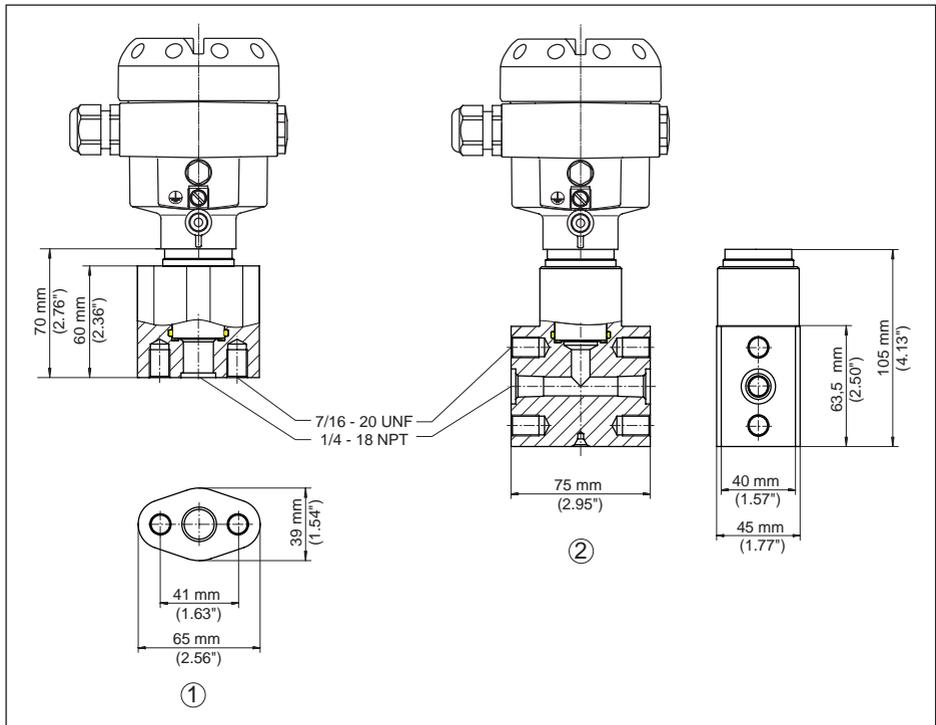

Fig. 64: CPT-2x, connection acc. to IEC 61518

- 1 Oval flange adapter
- 2 Top flange

For the version with temperature range up to 150 °C/302 °F, the measure of length increases by 28 mm (1.1 in).

For the version with "Second Line of Defense", the measure of length increases by 17 mm (0.67 in).

10.6 Trademark

All the brands as well as trade and company names used are property of their lawful proprietor/originator.

INDEX

A

- Adjust Date/Time 40
- Adjustment 36, 37
 - Process pressure 35, 36
 - System 31
 - Unit 33
- Adjustment menu 32

C

- Change the language 38
- Copy sensor settings 42

D

- Damping 37
- Default values 40
- Device ID 43
- Display lighting 39

E

- Electrical connection 22
- Error codes 48, 49
- Event memory 46

F

- Fault rectification 50
- Function blocks
 - Analog Input (AI) 66
 - Arithmetic 69
 - Discret Input (AI) 66
 - Input Selector 68
 - Integrator 68
 - Output Splitter 67
 - PID Control 66
 - Signal Characterizer 67
 - Transducer Block (TB) 66

L

- Linearisation 37

M

- Maintenance 45
- Measured value memory 46
- Measurement setup 17, 18, 19

N

- NAMUR NE 107 47

P

- Parameterization example 34
- Peak value indicator 39

- Position correction 34
- Pressure compensation 17
 - Ex d 16
 - Standard 16
- Process pressure measurement 18

R

- Reset
 - Basic settings 40
 - Delivery status 40

S

- Seal concept 10
- Service access 42
- Set display parameters 38
- Simulation 39

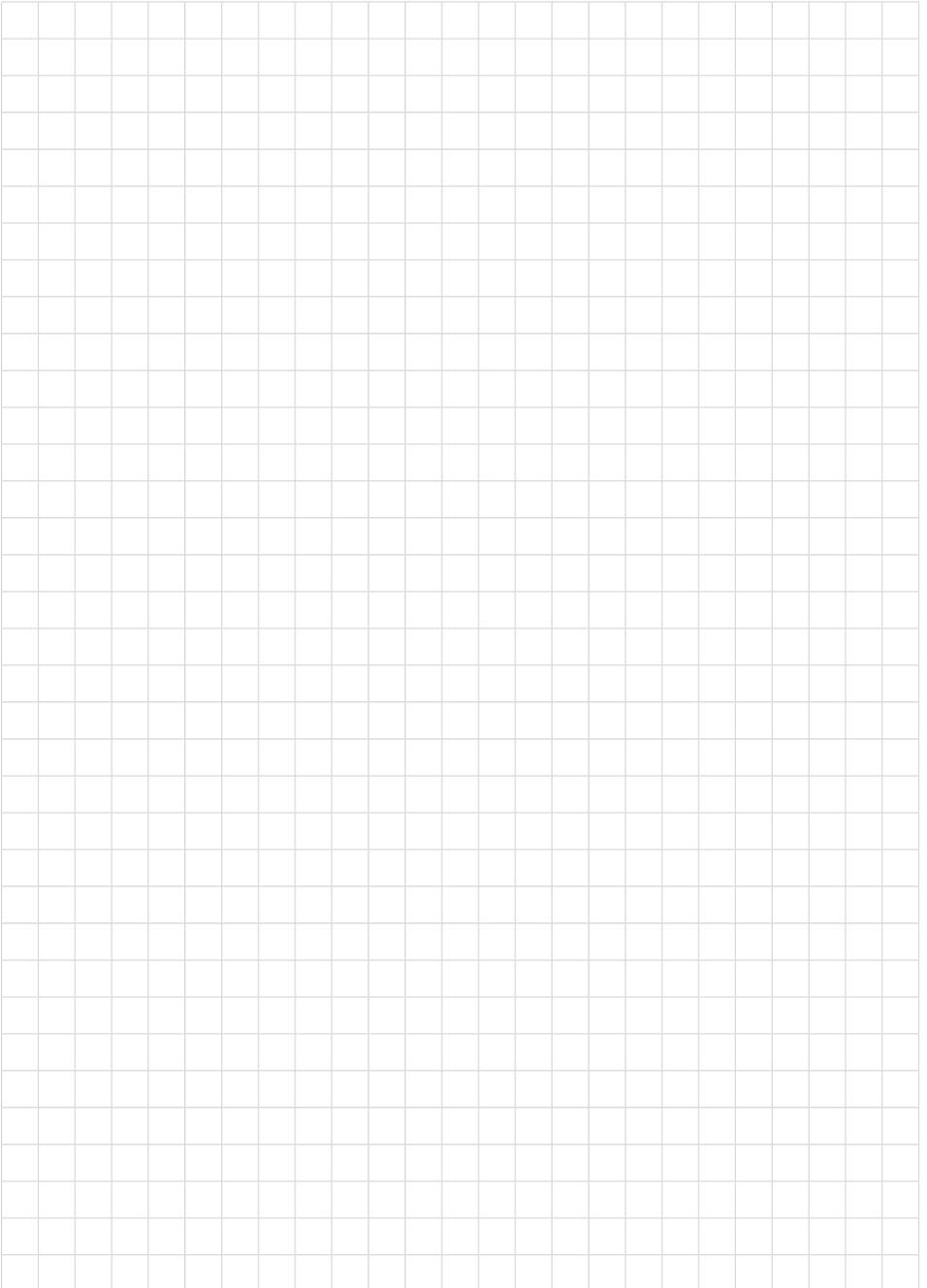

Printing date:

All statements concerning scope of delivery, application, practical use and operating conditions of the sensors and processing systems correspond to the information available at the time of printing.



WIKA Alexander Wiegand SE & Co. KG

Alexander-Wiegand-Straße 30

63911 Klingenberg

Germany

Phone (+49) 9372/132-0

Fax (+49) 9372 132-406

E-mail: info@wika.de

www.wika.de

52752-EN-190320