

Operating Instructions

Process pressure transmitter CPT-2x

GB

4 ... 20 mA/HART
With SIL qualification
Ceramic sensor



Process pressure transmitter CPT-2x



Contents

1	About this document	4
1.1	Function	4
1.2	Target group	4
1.3	Symbols used.....	4
2	For your safety	5
2.1	Authorised personnel	5
2.2	Appropriate use.....	5
2.3	Warning about incorrect use.....	5
2.4	General safety instructions	5
2.5	EU conformity.....	6
2.6	SIL qualification according to IEC 61508.....	6
2.7	Permissible process conditions	6
2.8	NAMUR recommendations	6
2.9	Installation and operation in the USA and Canada	7
3	Product description	8
3.1	Configuration.....	8
3.2	Principle of operation.....	9
3.3	Supplementary cleaning procedures.....	13
3.4	SIL features	14
3.5	Packaging, transport and storage.....	14
4	Mounting	16
4.1	General instructions	16
4.2	Ventilation and pressure compensation.....	17
4.3	Process pressure measurement.....	19
4.4	Level measurement.....	21
4.5	External housing	22
5	Connecting to power supply	23
5.1	Preparing the connection	23
5.2	Connecting.....	24
5.3	Single chamber housing.....	25
5.4	Double chamber housing	26
5.5	Housing IP 66/IP 68 (1 bar)	27
5.6	External housing with version IP 68 (25 bar).....	28
5.7	Switch-on phase.....	29
6	Functional safety (SIL)	31
6.1	Objective	31
6.2	SIL qualification.....	31
6.3	Application area	31
6.4	Safety concept of the parameterization	32
7	Set up with the display and adjustment module	34
7.1	Insert display and adjustment module	34
7.2	Adjustment system	35
7.3	Measured value indication.....	36
7.4	Parameter adjustment	37
7.5	Saving the parameterisation data	51

8	Setup with PACTware	52
8.1	Connect the PC.....	52
8.2	Parameter adjustment.....	52
8.3	Saving the parameterisation data.....	53
9	Diagnosis, asset management and service	54
9.1	Maintenance.....	54
9.2	Cleaning - hygienic connection with compression nut.....	54
9.3	Diagnosis memory.....	55
9.4	Asset Management function.....	56
9.5	Rectify faults.....	59
9.6	Exchange process module on version IP 68 (25 bar).....	60
9.7	Instrument repair.....	61
10	Dismount	62
10.1	Dismounting steps.....	62
10.2	Disposal.....	62
11	Supplement	63
11.1	Technical data.....	63
11.2	Calculation of the total deviation.....	77
11.3	Calculation of the total deviation - Practical example.....	77
11.4	Dimensions.....	80
11.5	Trademark.....	91

Safety instructions for Ex areas



Take note of the Ex specific safety instructions for Ex applications. These instructions are attached as documents to each instrument with Ex approval and are part of the operating instructions.

Editing status: 2019-03-11

1 About this document

1.1 Function

This operating instructions provides all the information you need for mounting, connection and setup as well as important instructions for maintenance, fault rectification, the exchange of parts and the safety of the user. Please read this information before putting the instrument into operation and keep this manual accessible in the immediate vicinity of the device.

1.2 Target group

This operating instructions manual is directed to trained personnel. The contents of this manual must be made available to the qualified personnel and implemented.

1.3 Symbols used



Information, tip, note

This symbol indicates helpful additional information.



Caution: If this warning is ignored, faults or malfunctions can result.



Warning: If this warning is ignored, injury to persons and/or serious damage to the instrument can result.



Danger: If this warning is ignored, serious injury to persons and/or destruction of the instrument can result.



Ex applications

This symbol indicates special instructions for Ex applications.



List

The dot set in front indicates a list with no implied sequence.



Action

This arrow indicates a single action.



Sequence of actions

Numbers set in front indicate successive steps in a procedure.



Battery disposal

This symbol indicates special information about the disposal of batteries and accumulators.

2 For your safety

2.1 Authorised personnel

All operations described in this documentation must be carried out only by trained, qualified personnel authorised by the plant operator. During work on and with the device, the required personal protective equipment must always be worn.

2.2 Appropriate use

The CPT-2x is a pressure transmitter for process pressure and hydrostatic level measurement.

You can find detailed information about the area of application in chapter "*Product description*".

Operational reliability is ensured only if the instrument is properly used according to the specifications in the operating instructions manual as well as possible supplementary instructions.

2.3 Warning about incorrect use

Inappropriate or incorrect use of this product can give rise to application-specific hazards, e.g. vessel overflow through incorrect mounting or adjustment. Damage to property and persons or environmental contamination can result. Also, the protective characteristics of the instrument can be impaired.

2.4 General safety instructions

This is a state-of-the-art instrument complying with all prevailing regulations and directives. The instrument must only be operated in a technically flawless and reliable condition. The operator is responsible for the trouble-free operation of the instrument. When measuring aggressive or corrosive media that can cause a dangerous situation if the instrument malfunctions, the operator has to implement suitable measures to make sure the instrument is functioning properly.

During the entire duration of use, the user is obliged to determine the compliance of the necessary occupational safety measures with the current valid rules and regulations and also take note of new regulations.

The safety instructions in this operating instructions manual, the national installation standards as well as the valid safety regulations and accident prevention rules must be observed by the user.

For safety and warranty reasons, any invasive work on the device beyond that described in the operating instructions manual may be carried out only by personnel authorised by the manufacturer. Arbitrary conversions or modifications are explicitly forbidden. For safety reasons, only the accessory specified by the manufacturer must be used.

To avoid any danger, the safety approval markings and safety tips on the device must also be observed and their meaning read in this operating instructions manual.

2.5 EU conformity

The device fulfils the legal requirements of the applicable EU directives. By affixing the CE marking, we confirm the conformity of the instrument with these directives.

2.6 SIL qualification according to IEC 61508

The Safety Integrity Level (SIL) of an electronic system is used to assess the reliability of integrated safety functions.

For detailed specification of the safety requirements, multiple SIL levels are specified according to safety standard IEC 61508. You can find detailed information in chapter "*Functional safety (SIL)*" of the operating instructions.

The instrument meets the specifications of IEC 61508: 2010 (Edition 2). It is qualified for single-channel operation up to SIL2. The instrument can be used homogeneously redundant up to SIL3 in multi-channel architecture with HFT 1.

2.7 Permissible process conditions

For safety reasons, the instrument must only be operated within the permissible process conditions. You can find detailed information on the process conditions in chapter "*Technical data*" as well as on the type label.

The permissible process pressure range is specified by "MWP" (Maximum Working Pressure) on the type label, see chapter "*Structure*". The MWP takes the element of the measuring cell and processing fitting combination with the weakest pressure into consideration and may be applied permanently. The specification refers to a reference temperature of +20 °C (+68 °F). It also applies when a measuring cell with a higher measuring range than the permissible pressure range of the process fitting is installed order-related.

In order to prevent damage to the device, the test pressure may only exceed the specified MWP briefly by 1.5 times at reference temperature. The pressure stage of the process fitting as well as the overload resistance of the measuring cell are taken into consideration here (see chapter "*Technical Data*").

In addition, a temperature derating of the process fitting, e. g. with flanges, can limit the permissible process pressure range according to the respective standard.

2.8 NAMUR recommendations

NAMUR is the automation technology user association in the process industry in Germany. The published NAMUR recommendations are accepted as the standard in field instrumentation.

The device fulfils the requirements of the following NAMUR recommendations:

- NE 21 – Electromagnetic compatibility of equipment
- NE 43 – Signal level for fault information from measuring transducers

- NE 53 – Compatibility of field devices and display/adjustment components
- NE 107 – Self-monitoring and diagnosis of field devices

For further information see www.namur.de.

2.9 Installation and operation in the USA and Canada

This information is only valid for USA and Canada. Hence the following text is only available in the English language.

Installations in the US shall comply with the relevant requirements of the National Electrical Code (ANSI/NFPA 70).

Installations in Canada shall comply with the relevant requirements of the Canadian Electrical Code

A Class 2 power supply unit has to be used for the installation in the USA and Canada.

3 Product description

3.1 Configuration

Scope of delivery

The scope of delivery encompasses:

- Instrument CPT-2x
- Documentation
 - Quick setup guide CPT-2x
 - Safety Manual (SIL)
 - Documentation instrument parameters (default values)
 - Documentation order-relating instrument parameters (deviation from default values)
 - Test certificate for pressure transmitters
 - Instructions for optional instrument features
 - Ex-specific "*Safety instructions*" (with Ex versions)
 - If necessary, further certificates



Information:

Optional instrument features are also described in this operating instructions manual. The respective scope of delivery results from the order specification.

Scope of this operating instructions

This operating instructions manual applies to the following instrument versions:

- Hardware from 1.0.0
- Software version from 1.2.4



Note:

You can find the hardware and software version of the instrument as follows:

- On the type plate of the electronics module
- In the adjustment menu under "*Info*"

Type label

The type label contains the most important data for identification and use of the instrument:

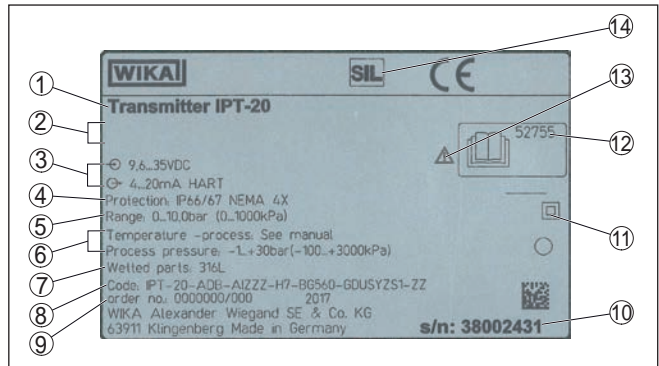

Fig. 1: Layout of the type label (example)

- 1 Instrument type
- 2 Field for approvals
- 3 Signal output and voltage supply
- 4 Technical data
- 5 Product code
- 6 Order number
- 7 Serial number of the instrument
- 8 Symbol of the device protection class
- 9 ID numbers, instrument documentation
- 10 Reminder to observe the instrument documentation
- 11 SIL identification

3.2 Principle of operation

Application area

CPT-2x is suitable for applications in virtually all industries. It is used for the measurement of the following pressure types.

- Gauge pressure
- Absolute pressure
- Vacuum

Measured products

Measured products are gases, vapours and liquids.

Depending on the process fitting and measurement setup, measured products can be also viscous or contain abrasive substances.

Measured variables

The CPT-2x is suitable for the measurement of the following process variables:

- Process pressure
- Level

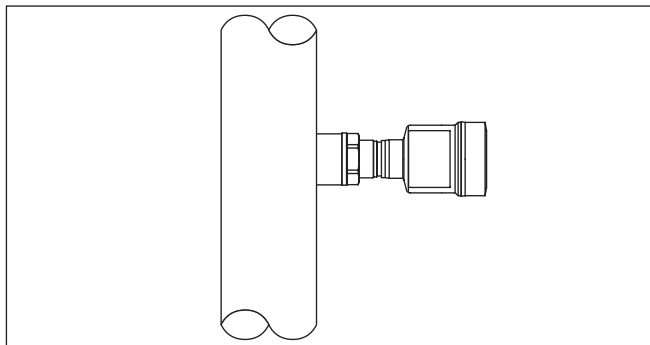

Fig. 2: Process pressure measurement CPT-2x



To reach the Safety Integrity Level (SIL) for the electronic differential pressure, both instruments must be SIL-qualified.

Measuring system pressure

Sensor element is the measuring cell with robust ceramic diaphragm. The process pressure deflects the ceramic diaphragm and causes a capacitance change in the measuring cell. This capacitance change is converted into an electrical signal and output as measured value via the output signal.

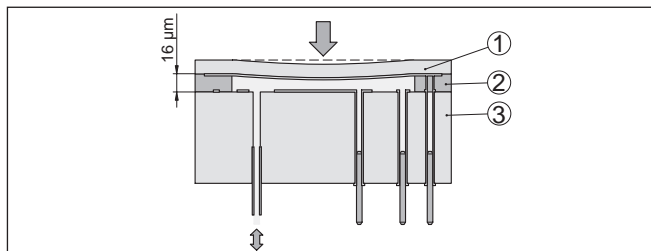

Fig. 3: Configuration of the ceramic measuring cell

- 1 Process diaphragm
- 2 Glass joint
- 3 Base element

The measuring cell is available in two sizes: \varnothing 28 mm and \varnothing 17.5 mm.

Measuring system temperature

Temperature sensors in the ceramic diaphragm and on the ceramic body of the \varnothing 28 mm measuring cell or on the electronics of the \varnothing 17.5 mm measuring cell detect the current process temperature. The temperature value is output via:

- The display and adjustment module
- The current output or the digital signal output

Extreme process temperature jumps are also immediately detected by the \varnothing 28 mm measuring cell. The values in the ceramic diaphragm are compared with that on the ceramic base body.

Within only a few measuring cycles the intelligent sensor electronics compensates unavoidable measurement deviations due to tempera-

ture shocks. Such shocks cause (depending on the set damping) only slight, brief changes to the output signal.

Pressure types

The measuring cell design depends on the selected pressure type.

Relative pressure: the measuring cell is open to the atmosphere. The ambient pressure is detected in the measuring cell and compensated. It thus has no influence on the measured value.

Absolute pressure: the measuring cell is evacuated and encapsulated. The ambient pressure is not compensated and does hence influence the measured value.

Seal concepts

The following presentations show examples for the installation of the ceramic measuring cell into the process fitting and the different seal concepts.

Recessed installation

The recessed installation is particularly suitable for applications with gases, vapours and clear liquids. The measuring cell seal is positioned laterally as well as in addition in front.

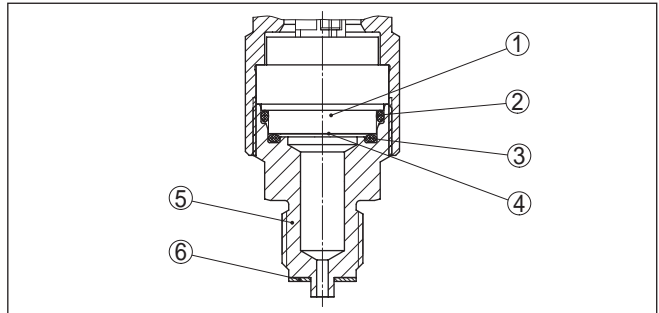

Fig. 4: Recessed installation of the measuring cell (example: manometer connection $G\frac{1}{2}$)

- 1 Measuring cell
- 2 Seal for the measuring cell
- 3 Additional, front seal for measuring cell
- 4 Diaphragm
- 5 Process fitting
- 6 Seal for the process fitting

Front-flush mounting with single seal

The front-flush installation is particularly suitable for applications with viscous and abrasive media and in case of buildup. The measuring cell seal is positioned laterally.

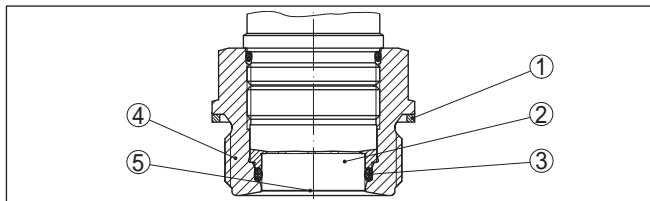

Fig. 5: Front-flush installation of the measuring cell (example: thread G1½)

- 1 Seal for the process fitting
- 2 Measuring cell
- 3 Seal for the measuring cell
- 4 Process fitting
- 5 Diaphragm

Completely front-flush mounting with single seal

The completely front-flush mounting is particularly suitable for applications in the paper industry. The diaphragm is in the pulp flow, is hence cleaned and protected against buildup.

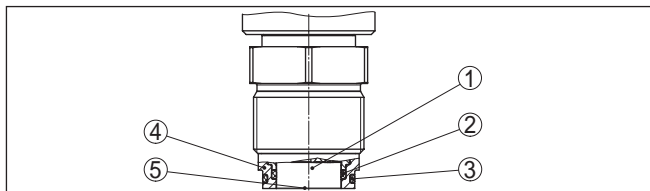

Fig. 6: Front-flush installation of the measuring cell (example: M30 x 1.5)

- 1 Measuring cell
- 2 Seal for the measuring cell
- 3 Seal for the process fitting
- 4 Process fitting
- 5 Diaphragm

Front-flush mounting with double seal

The front-flush installation is particularly suitable for applications with viscous media. The additional, front sealing protects the glass joint of the measuring cell against chemical attack and the measuring cell electronics against diffusion of aggressive gases from the process.

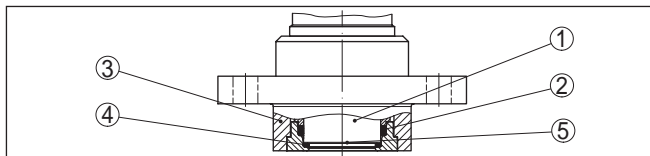

Fig. 7: Front-flush installation of the measuring cell with double seal (example: flange connection with extension)

- 1 Measuring cell
- 2 Seal for the measuring cell
- 3 Process fitting
- 4 Additional, front seal for measuring cell
- 5 Diaphragm

Installation in hygienic fitting

The front-flush, hygienic installation of the measuring cell is particularly suitable for food applications. The sealings are installed gap-free. The form seal of the measuring cell protects also the glass joint.

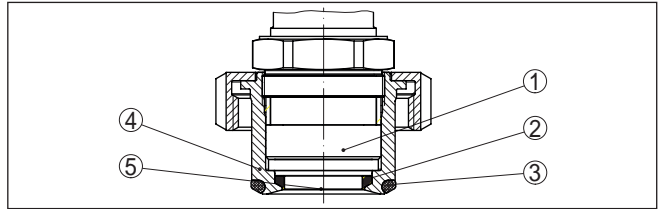

Fig. 8: Hygienic installation of the measuring cell (example: hygienic fitting with compression nut)

- 1 Measuring cell
- 2 Form seal for the measuring cell
- 3 Gap-free seal for process fitting
- 4 Process fitting
- 5 Diaphragm

Installation in hygienic fitting acc. to 3-A

The front-flush, hygienic installation of the measuring cell acc. to 3-A is particularly suitable for food applications. The sealings are installed gap-free. The additional front sealing for the measuring cell protects also the glass joint. A hole in the process fitting is used for leakage detection.

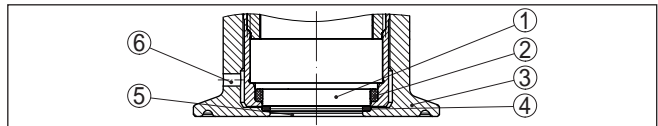

Fig. 9: Hygienic installation of the measuring cell acc. to 3-A (example: Clamp connection)

- 1 Measuring cell
- 2 Seal for the measuring cell
- 3 Process fitting
- 4 Additional, front seal for measuring cell
- 5 Diaphragm
- 6 Hole for leakage detection

3.3 Supplementary cleaning procedures

The CPT-2x is also available in the version "Oil, grease and silicone-free". These instruments have passed through a special cleaning procedure to remove oil, grease and paint-wetting impairment substances (PWIS).

The cleaning is carried out on all wetted parts as well as on surfaces accessible from outside. To keep the purity level, the instruments are immediately packed in plastic foil after the cleaning process. The purity level remains as long as the instrument is kept in the closed original packaging.

**Caution:**

The CPT-2x in this version may not be used in oxygen applications. For this purpose, instruments are available in the special version "*Oil and grease-free for oxygen applications*".

3.4 SIL features

The CPT-2x 4 ... 20 mA/HART with SIL qualification differs from the standard instrument in the following points:

- Type label: with SIL logo
- Scope of delivery: with Safety Manual and documentation of the device parameters
- Parameter adjustment: Device status "*Function Check*" is output during the parameter adjustment, the safety function is deactivated
- Measured value output: "*Failure*" is output when the measured value $< -20\%$ or $> +120\%$ of the nominal measuring range
- Adjustment menu, "*Current output*": Failure mode 20.5 mA not selectable
- Adjustment menu, "*HART mode*": Selection "*Analogue current output*" is unmodifiably preset
- Electronics temperature: in case of temperature values outside the permitted range, "*Failure*" is output
- Some diaphragm coatings not permissible

**Information:**

The measures that must be implemented to use the instrument in safety-instrumented systems are described in the "*Safety Manual*". The SIL function can be deactivated neither by the user nor by service personnel.

3.5 Packaging, transport and storage**Packaging**

Your instrument was protected by packaging during transport. Its capacity to handle normal loads during transport is assured by a test based on ISO 4180.

The packaging of standard instruments consists of environment-friendly, recyclable cardboard. For special versions, PE foam or PE foil is also used. Dispose of the packaging material via specialised recycling companies.

Transport

Transport must be carried out in due consideration of the notes on the transport packaging. Nonobservance of these instructions can cause damage to the device.

Transport inspection

The delivery must be checked for completeness and possible transit damage immediately at receipt. Ascertained transit damage or concealed defects must be appropriately dealt with.

Storage

Up to the time of installation, the packages must be left closed and stored according to the orientation and storage markings on the outside.

Unless otherwise indicated, the packages must be stored only under the following conditions:

- Not in the open
- Dry and dust free
- Not exposed to corrosive media
- Protected against solar radiation
- Avoiding mechanical shock and vibration

Storage and transport temperature

- Storage and transport temperature see chapter "*Supplement - Technical data - Ambient conditions*"
- Relative humidity 20 ... 85 %

Lifting and carrying

With instrument weights of more than 18 kg (39.68 lbs) suitable and approved equipment must be used for lifting and carrying.

4 Mounting

4.1 General instructions

Process conditions

Make sure before mounting that all parts of the instrument exposed to the process are suitable for the existing process conditions.

These are mainly:

- Active measuring component
- Process fitting
- Process seal

Process conditions in particular are:

- Process pressure
- Process temperature
- Chemical properties of the medium
- Abrasion and mechanical influences

You can find detailed information on the process conditions in chapter "*Technical data*" as well as on the type label.

Protection against moisture

Protect your instrument against moisture ingress through the following measures:

- Use a suitable connection cable (see chapter "*Connecting to power supply*")
- Tighten the cable gland or plug connector
- When mounting horizontally, turn the housing so that the cable gland or plug connector point downward
- Lead the connection cable downward in front of the cable entry or plug connector

This applies mainly to outdoor installations, in areas where high humidity is expected (e.g. through cleaning processes) and on cooled or heated vessels.

To maintain the housing protection, make sure that the housing lid is closed during operation and locked, if necessary.

Make sure that the degree of contamination specified in chapter "*Technical data*" meets the existing ambient conditions.

Screwing in

On devices with a threaded fitting, the hexagon on the process fitting must be tightened with a suitable wrench.

See chapter "*Dimensions*" for wrench size.



Warning:

The housing or the electrical connection may not be used for screwing in! Tightening can cause damage, e. g. to the rotation mechanism of the housing.

Vibrations

If there is strong vibration at the mounting location, the instrument version with external housing should be used. See chapter "*External housing*".

Process pressure range - Mounting accessory

The permissible process pressure range is stated on the type label. The instrument should only be operated with these pressures if the mounting accessory used also fulfils these values. This should be ensured by suitable flanges, welded sockets, tension rings with Clamp connections, sealings, etc.

Temperature limits

Higher process temperatures often mean also higher ambient temperatures. Make sure that the upper temperature limits stated in chapter "*Technical data*" for the environment of the electronics housing and connection cable are not exceeded.

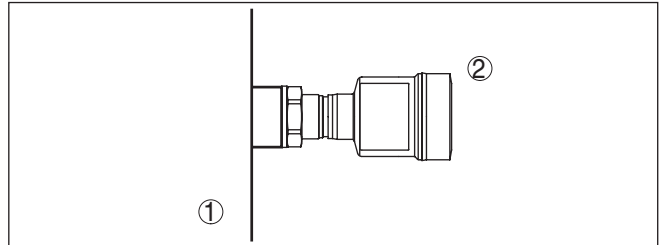

Fig. 10: Temperature ranges

- 1 Process temperature
- 2 Ambient temperature

4.2 Ventilation and pressure compensation**Filter element - Function**

The filter element in the electronics housing has the following functions:

- Ventilation of the electronics housing
- Atmospheric pressure compensation (with relative pressure measuring ranges)

**Caution:**

The filter element causes a time-delayed pressure compensation. When quickly opening/closing the housing cover, the measured value can change for approx. 5 s by up to 15 mbar.

For an effective ventilation, the filter element must be always free from buildup. In case of horizontal mounting, turn the housing so that the filter element points downward after the instrument is installed. This provides better protection against buildup.

**Caution:**

Do not use a high-pressure cleaner. The filter element could be damaged, which would allow moisture into the housing.

The following paragraphs describe how the filter element is arranged in the different instrument versions.

Filter element - Position

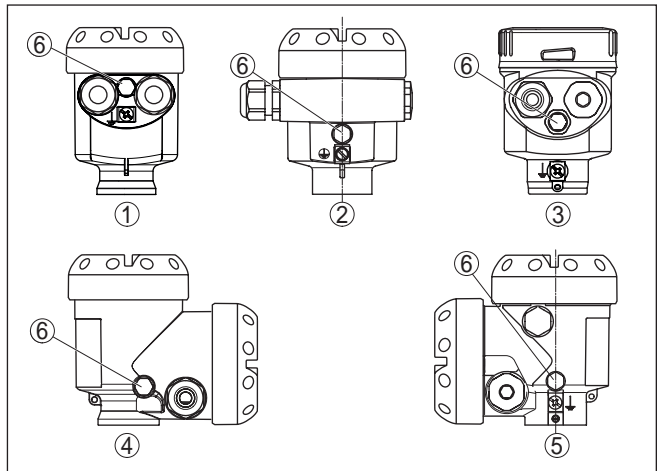

Fig. 11: Position of the filter element

- 1 Plastic, stainless steel single chamber (precision casting)
- 2 Aluminium - single chamber
- 3 Stainless steel single chamber (electropolished)
- 4 Plastic double chamber
- 5 Aluminium - double chamber
- 6 Filter element

With the following instruments a blind plug is installed instead of the filter element:

- Instruments in protection IP 66/IP 68 (1 bar) - ventilation via capillaries in non-detachable cable
- Instruments with absolute pressure

Filter element - Position
Ex-d version

- Turn the metal ring in such a way that the filter element points downward after installation of the instrument. This provides better protection against buildup.

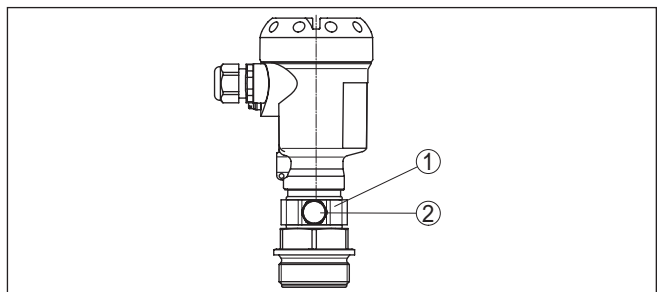

Fig. 12: Position of the filter element - Ex-d version

- 1 Rotatable metal ring
- 2 Filter element

Instruments with absolute pressure have a blind plug mounted instead of the filter element.

**Filter element - Position
Second Line of Defense**

The Second Line of Defense (SLOD) is a second level of the process separation in form of a gas-tight leadthrough in the housing neck, preventing products from penetrating into the housing.

With these instruments, the process assembly is completely encapsulated. An absolute pressure measuring cell is used so that no ventilation is required.

With relative pressure measuring ranges, the ambient pressure is detected and compensated by a reference sensor in the electronics.

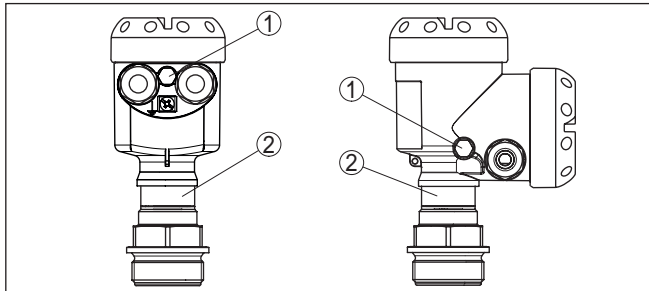

Fig. 13: Position of the filter element - gastight leadthrough

- 1 Filter element
- 2 Gas-tight leadthrough

**Filter element - Position
IP 69K version**

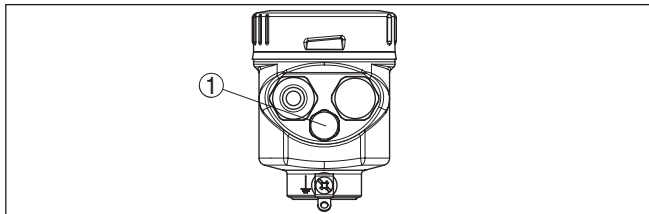

Fig. 14: Position of the filter element - IP 69K version

- 1 Filter element

Instruments with absolute pressure have a blind plug mounted instead of the filter element.

4.3 Process pressure measurement

Keep the following in mind when setting up the measuring system:

- Mount the instrument above the measuring point

Possible condensation can then drain off into the process line.

**Measurement setup in
gases**

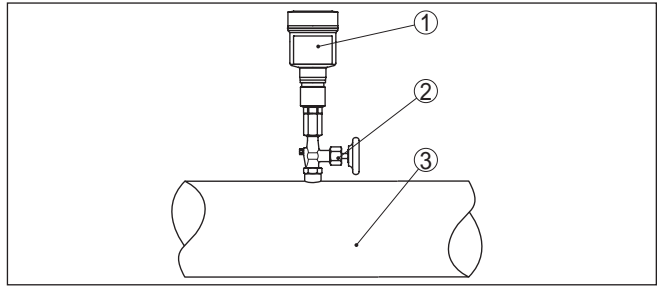

Fig. 15: Measurement setup for process pressure measurement of gases in pipelines

- 1 CPT-2x
- 2 Blocking valve
- 3 Pipeline

Measurement setup in vapours

Keep the following in mind when setting up the measuring system:

- Connect via a siphon
- Do not insulate the siphon
- Fill the siphon with water before setup

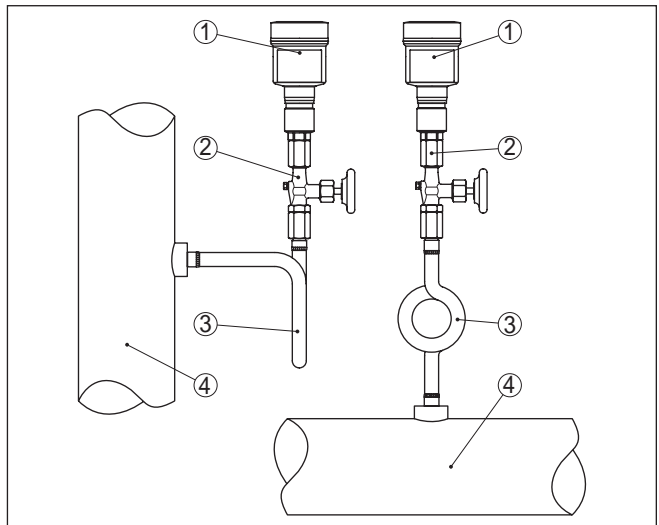

Fig. 16: Measurement setup with process pressure measurement of gases in pipelines

- 1 CPT-2x
- 2 Blocking valve
- 3 Siphon in U or circular form
- 4 Pipeline

A protective accumulation of water is formed through condensation in the pipe bends. Even in applications with hot steam, a medium temperature $< 100\text{ }^{\circ}\text{C}$ on the transmitter is ensured.

Measurement setup in liquids

Keep the following in mind when setting up the measuring system:

- Mount the instrument below the measuring point

The effective pressure line is always filled with liquid and gas bubbles can bubble up to the process line.

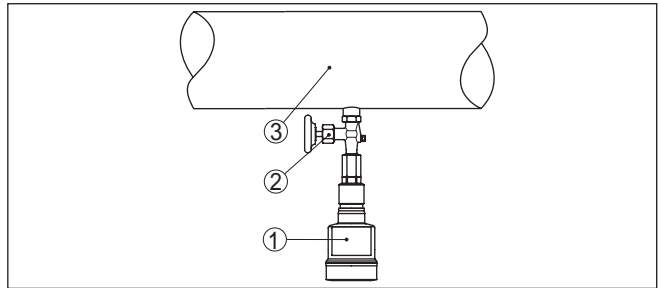

Fig. 17: Measurement setup for process pressure measurement of liquids in pipelines

- 1 CPT-2x
- 2 Blocking valve
- 3 Pipeline

4.4 Level measurement

Measurement setup

Keep the following in mind when setting up the measuring system:

- Mount the instrument below the min. level
- Do not mount the instrument close to the filling stream or emptying area
- Mount the instrument so that it is protected against pressure shocks from the stirrer

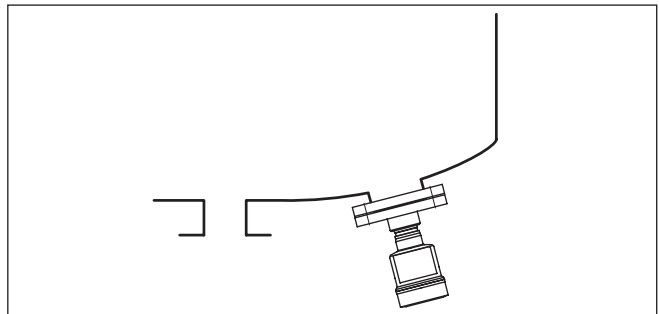

Fig. 18: Measurement setup for level measurement

4.5 External housing

Configuration

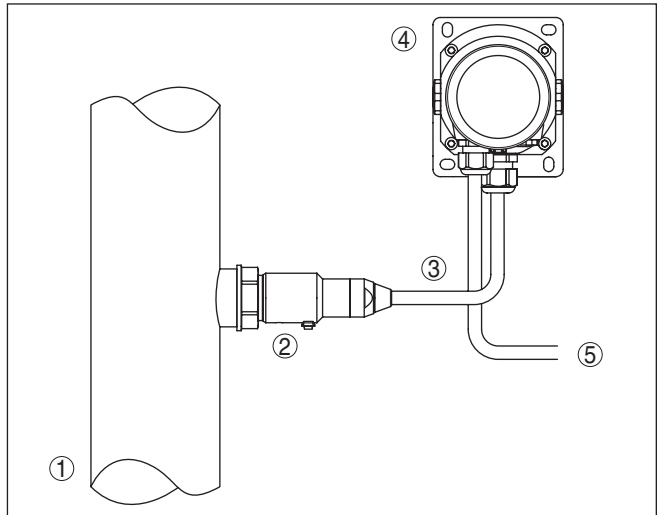

Fig. 19: Configuration, process module, external housing

- 1 Pipeline
- 2 Process module
- 3 Connection cable process assembly - External housing
- 4 External housing
- 5 Signal cable

5 Connecting to power supply

5.1 Preparing the connection

Safety instructions

Always keep in mind the following safety instructions:

- Carry out electrical connection by trained, qualified personnel authorised by the plant operator
- If overvoltage surges are expected, overvoltage arresters should be installed



Warning:

Connect only in the complete absence of line voltage.

Voltage supply

Power supply and current signal are carried on the same two-wire cable. The operating voltage can differ depending on the instrument version.

The data for power supply are specified in chapter "*Technical data*".

Provide a reliable separation between the supply circuit and the mains circuits according to DIN EN 61140 VDE 0140-1.

Power the instrument via an energy-limited circuit acc. to IEC 61010-1, e.g. via Class 2 power supply unit.

Keep in mind the following additional factors that influence the operating voltage:

- Lower output voltage of the power supply unit under nominal load (e.g. with a sensor current of 20.5 mA or 22 mA in case of fault)
- Influence of additional instruments in the circuit (see load values in chapter "*Technical data*")

Connection cable

The instrument is connected with standard two-wire cable without screen. If electromagnetic interference is expected which is above the test values of EN 61326-1 for industrial areas, screened cable should be used.

Use cable with round cross section for instruments with housing and cable gland. Use a cable gland suitable for the cable diameter to ensure the seal effect of the cable gland (IP protection rating).

We generally recommend the use of shielded cable for HART multidrop mode.

Cable screening and grounding

If screened cable is required, we recommend connecting the cable screening on both ends to ground potential. In the sensor, the cable screening must be connected directly to the internal ground terminal. The ground terminal on the outside of the housing must be connected to the ground potential (low impedance).



In Ex systems, the grounding is carried out according to the installation regulations.

In electroplating plants as well as plants for cathodic corrosion protection it must be taken into account that significant potential differences exist. This can lead to unacceptably high currents in the cable screen if it is grounded at both ends.



Information:

The metallic parts of the instrument (process fitting, sensor, concentric tube, etc.) are connected with the internal and external ground terminal on the housing. This connection exists either directly via the conductive metallic parts or, in case of instruments with external electronics, via the screen of the special connection cable.

You can find specifications on the potential connections inside the instrument in chapter "*Technical data*".

Cable glands

Metric threads

In the case of instrument housings with metric thread, the cable glands are screwed in at the factory. They are sealed with plastic plugs as transport protection.

You have to remove these plugs before electrical connection.

NPT thread

In the case of instrument housings with self-sealing NPT threads, it is not possible to have the cable entries screwed in at the factory. The free openings for the cable glands are therefore covered with red dust protection caps as transport protection.

Prior to setup you have to replace these protective caps with approved cable glands or close the openings with suitable blind plugs.

On plastic housings, the NPT cable gland or the Conduit steel tube must be screwed into the threaded insert without grease.

Max. torque for all housings, see chapter "*Technical data*".

5.2 Connecting

Connection technology

The voltage supply and signal output are connected via the spring-loaded terminals in the housing.

Connection to the display and adjustment module or to the interface adapter is carried out via contact pins in the housing.



Information:

The terminal block is pluggable and can be removed from the electronics. To do this, lift the terminal block with a small screwdriver and pull it out. When reinserting the terminal block, you should hear it snap in.

Connection procedure

Proceed as follows:

1. Unscrew the housing lid
2. If a display and adjustment module is installed, remove it by turning it slightly to the left
3. Loosen compression nut of the cable gland and remove blind plug
4. Remove approx. 10 cm (4 in) of the cable mantle, strip approx. 1 cm (0.4 in) of insulation from the ends of the individual wires
5. Insert the cable into the sensor through the cable entry

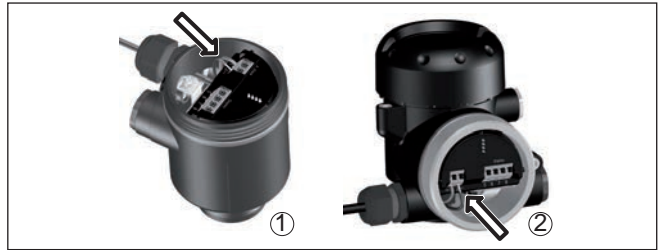

Fig. 20: Connection steps 5 and 6

- 1 Single chamber housing
- 2 Double chamber housing

6. Insert the wire ends into the terminals according to the wiring plan



Information:

Solid cores as well as flexible cores with wire end sleeves are inserted directly into the terminal openings. In case of flexible cores without end sleeves, press the terminal from above with a small screwdriver, the terminal opening is then free. When the screwdriver is released, the terminal closes again.

You can find further information on the max. wire cross-section under "Technical data - Electromechanical data".

7. Check the hold of the wires in the terminals by lightly pulling on them
8. Connect the screen to the internal ground terminal, connect the external ground terminal to potential equalisation
9. Tighten the compression nut of the cable entry gland. The seal ring must completely encircle the cable
10. Reinsert the display and adjustment module, if one was installed
11. Screw the housing lid back on

The electrical connection is finished.

5.3 Single chamber housing



The following illustration applies to the non-Ex, Ex-ia and Ex-d version.

Electronics and connection compartment

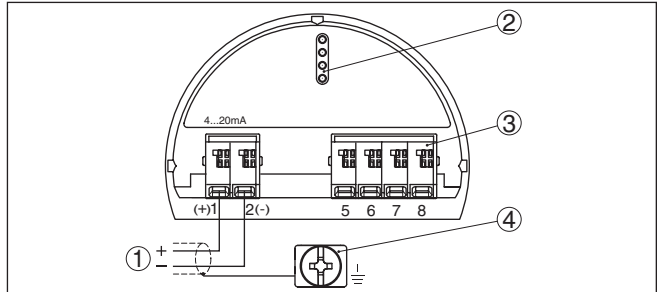

Fig. 21: Electronics and connection compartment - single chamber housing

- 1 Voltage supply, signal output
- 2 For display and adjustment module or interface adapter
- 3 For external display and adjustment unit or Slave sensor
- 4 Ground terminal for connection of the cable screening

5.4 Double chamber housing



The following illustrations apply to the non-Ex as well as to the Ex-ia version.

Electronics compartment

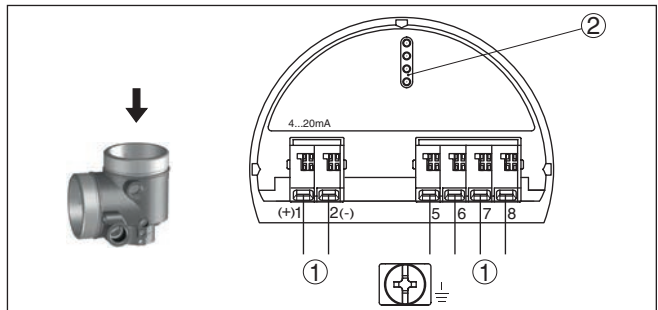

Fig. 22: Electronics compartment - double chamber housing

- 1 Internal connection to the connection compartment
- 2 For display and adjustment module or interface adapter

Connection compartment

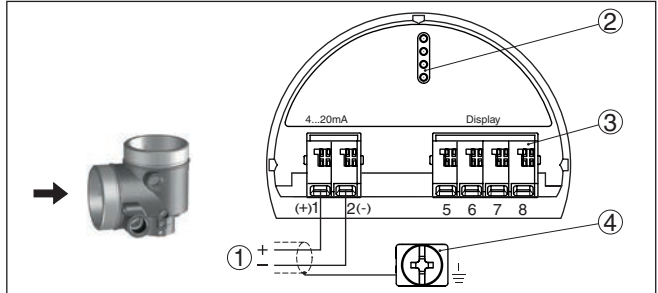

Fig. 23: Connection compartment - double chamber housing

- 1 Voltage supply, signal output
- 2 For display and adjustment module or interface adapter
- 3 For external display and adjustment unit
- 4 Ground terminal for connection of the cable screening

Wire assignment, connection cable

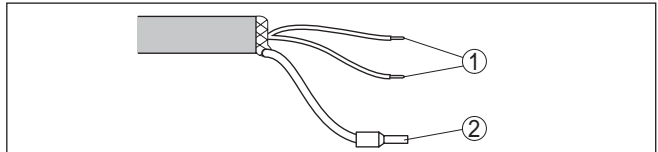

Fig. 24: Wire assignment in permanently connected connection cable

- 1 Brown (+) and blue (-) to power supply or to the processing system
- 2 Shielding

5.6 External housing with version IP 68 (25 bar)

Overview

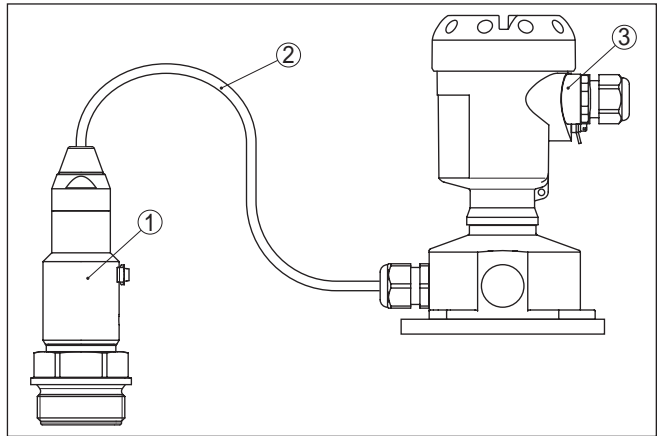

Fig. 25: CPT-2x in IP 68 version 25 bar with axial cable outlet, external housing

- 1 Transmitter
- 2 Connection cable
- 3 External housing

Electronics and connection compartment for power supply

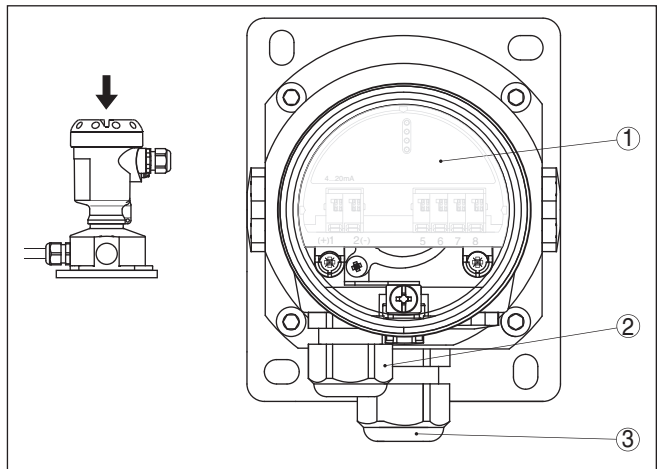

Fig. 26: Electronics and connection compartment

- 1 Electronics module
- 2 Cable gland for voltage supply
- 3 Cable gland for connection cable, transmitter

Terminal compartment, housing socket

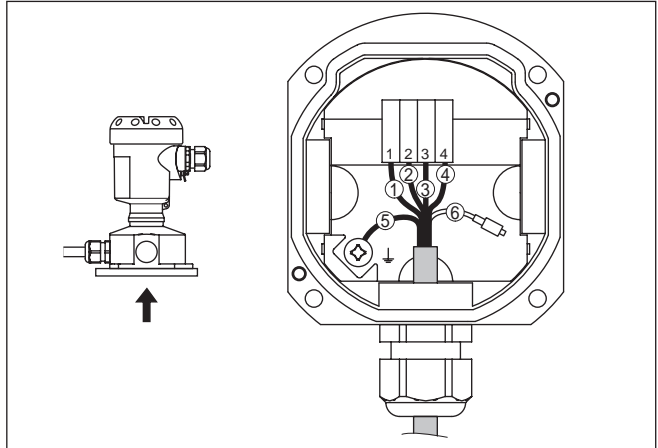

Fig. 27: Connection of the process component in the housing base

- 1 Yellow
- 2 White
- 3 Red
- 4 Black
- 5 Shielding
- 6 Breather capillaries

Electronics and connection compartment

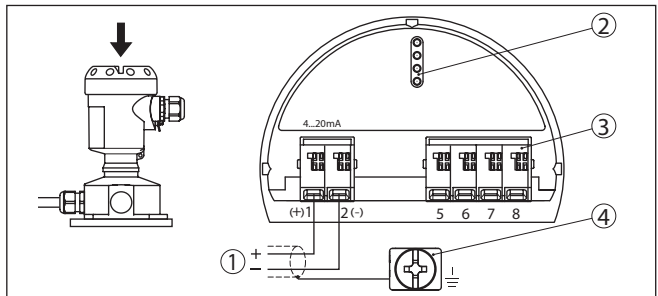

Fig. 28: Electronics and connection compartment external housing

- 1 Voltage supply/Signal output
- 2 For display and adjustment module or interface adapter
- 3 For external display and adjustment unit or Slave sensor
- 4 Ground terminal for connection of the cable screening

5.7 Switch-on phase

After connecting the instrument to power supply or after a voltage recurrence, the instrument carries out a self-check for approx. 5 s:

- Internal check of the electronics
- Indication of a status message on the display or PC
- Output signal at instruments with current output jumps to the set fault current

Then the actual measured value is output to the signal cable. The value takes into account settings that have already been carried out, e.g. default setting.

6 Functional safety (SIL)

6.1 Objective

Background

In case of dangerous failures, processing facilities and machines can cause risks for persons, environment and property. The risk of such failures must be judged by the plant operator. Dependent thereon are measures for risk reduction through error prevention, error detection and fault control.

Plant safety by risk reduction

The part of plant safety depending on the correct functioning of safety-related components for risk reduction is called functional safety. Components used in such safety-instrumented systems (SIS) must therefore execute their intended function (safety function) with a defined high probability.

Standards and safety levels

The safety requirements for such components are described in the international standards IEC 61508 and 61511, which set the standard for uniform and comparable judgement of instrument and plant (or machine) safety and hence contribute to worldwide legal certainty. We distinguish between four safety levels, from SIL1 for low risk to SIL4 for very high risk (SIL = Safety Integrity Level), depending on the required degree of risk reduction.

6.2 SIL qualification

Properties and requirements

When developing instruments that can be used in safety-instrumented systems, the focus is on avoiding systematic errors as well as determining and controlling random errors.

Here are the most important characteristics and requirements from the perspective of functional safety according to IEC 61508 (Edition 2):

- Internal monitoring of safety-relevant circuit parts
- Extended standardization of the software development
- In case of failure, switching of the safety-relevant outputs to a defined safe state
- Determination of the failure probability of the defined safety function
- Reliable parameterization with non-safe user environment
- Proof test

Safety Manual

The SIL qualification of components is specified in a manual on functional safety (Safety Manual). Here, you can find all safety-relevant characteristics and information the user and the planner need for planning and operating the safety-instrumented system. This document is attached to each instrument with SIL rating and can be also found on our homepage via the instrument search.

6.3 Application area

The instrument can be used, for example, for process pressure and hydrostatic level measurement of liquids in safety-instrumented sys-

tems (SIS) acc. to IEC 61508 and IEC 61511. Note the specifications in the Safety Manual.

The following inputs/outputs are permitted:

- 4 ... 20 mA current output

6.4 Safety concept of the parameterization

The following tools are permitted for parameterization of the safety function:

- The integrated display and adjustment unit for on-site adjustment
- The DTM suitable for the signal conditioning instrument in conjunction with an adjustment software according to the FDT/DTM standard, e. g. PACTware

Tool for operation and parameterization



Note:

For operation of the CPT-2x an actual DTM Collection is required. The modification of safety-relevant parameters is only possible with active connection to the instrument (online mode).

Safe parameterization

To avoid possible errors during parameterisation in a non-safe operating environment, a verification procedure is used that enables reliable detection of parameter adjustment errors. The safety-relevant parameters have to be verified after they are saved in the instrument. In normal operating condition, the instrument is also protected (locked) against inadvertent or unauthorized parameter changes. This concept applies to adjustment directly on the instrument as well as adjustment with PACTware and DTM.

Safety-relevant parameters

To prevent unintentional or unauthorized adjustment, the set parameters must be protected from unauthorized access. For this reason the instrument is shipped in locked condition. The PIN in delivery status is "0000".

When shipped with a specific parameter adjustment, the instruments are accompanied by a list with the values deviating from the basic setting.

All safety-relevant parameters must be verified after a change.

The parameter settings of the measurement loop must be documented. You can find a list of all safety-relevant parameters in the delivery status in chapter "*Setup with the display and adjustment module*" under "*Additional adjustments - Reset*". In addition, a list of the safety-relevant parameters can be stored and printed via PACTware/DTM.

Unlock adjustment

For each parameter change, the instrument must be unlocked via a PIN (see chapter "*Setup steps - Lock adjustment*"). The device status is indicated by the symbol of an unlocked or locked padlock.

In delivery status, the PIN is **0000**.

Unsafe device status



Warning:

If adjustment is enabled, the safety function must be considered as unreliable. This applies until the parameterisation is terminated

correctly. If necessary, other measures must be taken to maintain the safety function.

Change parameters

All parameters changed by the operator are automatically stored temporarily so that they can be verified in the next step.

Verify parameters/Lock adjustment

After setup, the modified parameters must be verified (confirm the correctness of the parameters). To do this, you first have to enter the PIN. Here the adjustment is locked automatically. Then you carry out a comparison of two character strings. You must confirm that the character strings are identical. This is used to check the character presentation.

Then you confirm that the serial number of your instrument has been carried over correctly. This is used to check device communication.

Then, all modified parameters that have to be confirmed are listed. After this process is terminated, the safety function is again ensured.

Incomplete process



Warning:

If the described process was not carried out completely or correctly (e.g. due to interruption or voltage loss), the instrument remains in an unlocked, and thus unsafe, status.

Instrument reset



Warning:

In case of a reset to basic settings, all safety-relevant parameters will also be reset to default. Therefore all safety-relevant parameters must be checked or readjusted.

7 Set up with the display and adjustment module

7.1 Insert display and adjustment module

The display and adjustment module can be inserted into the sensor and removed again at any time. You can choose any one of four different positions - each displaced by 90°. It is not necessary to interrupt the power supply.

Proceed as follows:

1. Unscrew the housing lid
2. Place the display and adjustment module on the electronics in the desired position and turn it to the right until it snaps in.
3. Screw housing lid with inspection window tightly back on

Disassembly is carried out in reverse order.

The display and adjustment module is powered by the sensor, an additional connection is not necessary.



Fig. 29: Installing the display and adjustment module in the electronics compartment of the single chamber housing

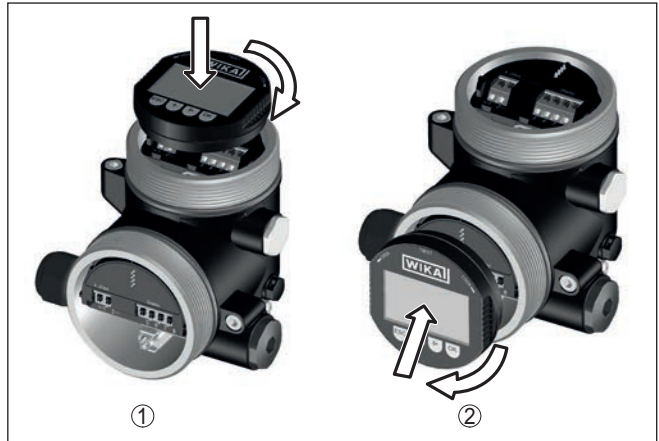

Fig. 30: Installing the display and adjustment module in the double chamber housing

- 1 In the electronics compartment
- 2 In the connection compartment



Note:

If you intend to retrofit the instrument with a display and adjustment module for continuous measured value indication, a higher lid with an inspection glass is required.

7.2 Adjustment system

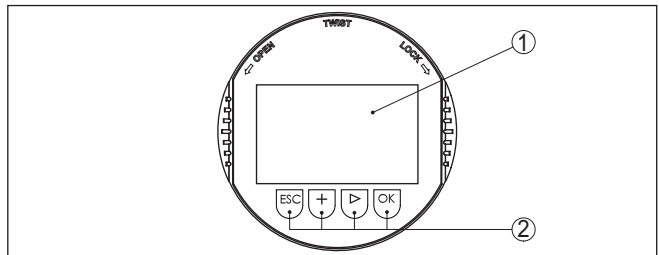

Fig. 31: Display and adjustment elements

- 1 LC display
- 2 Adjustment keys

Key functions

- **[OK]** key:
 - Move to the menu overview
 - Confirm selected menu
 - Edit parameter
 - Save value
- **[->]** key:
 - Change measured value presentation
 - Select list entry
 - Select menu items

- Select editing position
- **[+]** key:
 - Change value of the parameter
- **[ESC]** key:
 - Interrupt input
 - Jump to next higher menu

Adjustment system

The instrument is operated via the four keys of the display and adjustment module. The individual menu items are shown on the LC display. You can find the function of the individual keys in the previous illustration.

Time functions

When the **[+]** and **[->]** keys are pressed quickly, the edited value, or the cursor, changes one value or position at a time. If the key is pressed longer than 1 s, the value or position changes continuously.

When the **[OK]** and **[ESC]** keys are pressed simultaneously for more than 5 s, the display returns to the main menu. The menu language is then switched over to "English".

Approx. 60 minutes after the last pressing of a key, an automatic reset to measured value indication is triggered. Any values not confirmed with **[OK]** will not be saved.

7.3 Measured value indication

Measured value indication

With the **[->]** key you can move between three different indication modes.

In the first view, the selected measured value is displayed in large digits.

In the second view, the selected measured value and a corresponding bar graph presentation are displayed.

In the third view, the selected measured value as well as a second selectable value, e.g. the temperature, are displayed.

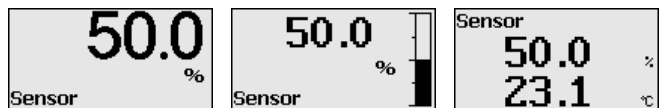

With the **"OK"** key you move (during the initial setup of the instrument) to the selection menu "Language".

Selection language

In this menu item, you can select the national language for further parameterization.

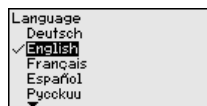

With the **[->]** button, you can select the requested language, with **"OK"** you confirm the selection and move to the main menu.

You can change your selection afterwards with the menu item "Setup - Display, Menu language".

7.4 Parameter adjustment

Main menu

The main menu is divided into five sections with the following functions:

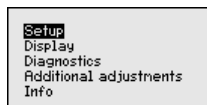

Setup: Settings, e.g., for measurement loop name, application, units, position correction, adjustment, signal output

Display: Settings, e.g., for language, measured value display, lighting

Diagnosis: Information, e.g. on instrument status, pointer, measurement reliability, simulation

Additional adjustments: PIN, date/time, reset, copy function

Info: Instrument name, hardware and software version, date of manufacture, sensor features



Note:

For optimum adjustment of the measuring point, the individual sub-menu items in the main menu item "Setup" should be selected one after the other and provided with the correct parameters. If possible, go through the items in the given sequence.

The submenu points are described below.

Operating sequence

A parameter change with SIL qualified instruments must always be carried out as follows:

- Unlock adjustment
- Change parameters
- Lock adjustment and verify modified parameters

This ensures that all modified parameters have been deliberately changed.

Unlock adjustment

The instrument is shipped in locked condition.

To prevent unintentional or unauthorized adjustment, the instrument is protected (locked) against all parameter changes while in normal operating condition.

For each parameter change you have to enter the PIN of the instrument. In delivery status, the PIN is "0000".

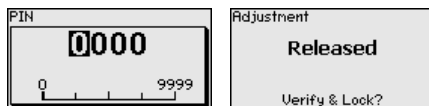

Change parameters

You can find a description below the respective parameter.

Lock adjustment and verify modified parameters

You can find a description below the parameter "Setup - Lock adjustment".

Setup - Measurement loop name

In the menu item "Sensor TAG" you edit a twelve-digit measurement loop designation.

You can enter an unambiguous designation for the sensor, e.g. the measurement loop name or the tank or product designation. In digital systems and in the documentation of larger plants, a singular designation must be entered for exact identification of individual measuring points.

The available digits include:

- Letters from A ... Z
- Numbers from 0 ... 9
- Special characters +, -, /, -

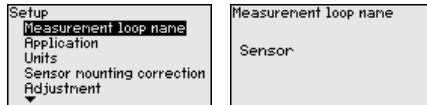

Setup - Application

In this menu item you activate/deactivate the slave sensor for electronic differential pressure and select the application.

CPT-2x can be used for process pressure and level measurement. The setting in the delivery status is process pressure measurement. The mode can be changed in this adjustment menu.

If you have connected **no** slave sensor, you confirm this with "Deactivate".

Depending on the selected application, different subchapters in the following adjustment steps are important. There you can find the individual adjustment steps.

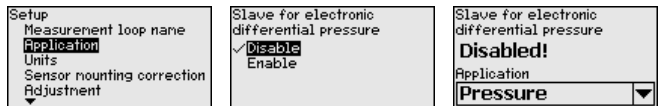

Enter the requested parameters via the appropriate keys, save your settings with [OK] and jump to the next menu item with the [ESC] and the [->] key.

Setup - Units

In this menu item, the adjustment units of the instrument are determined. The selection determines the unit displayed in the menu items "Min. adjustment (Zero)" and "Max. adjustment (Span)".

Unit of measurement:

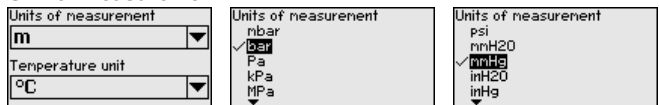

If the level should be adjusted in a height unit, the density of the medium must also be entered later during the adjustment.

In addition, the temperature unit of the instrument is specified. The selection determines the unit displayed in menu items "Peak value, temperature" and "in the variables of the digital output signal".

Temperature unit:

Units of measurement m	Temperature unit K
Temperature unit °C	

Enter the requested parameters via the appropriate keys, save your settings with **[OK]** and jump to the next menu item with the **[ESC]** and the **[->]** key.

Setup - Position correction

Especially with chemical seal systems, the installation position of the instrument can shift (offset) the measured value. Position correction compensates this offset. In the process, the actual measured value is taken over automatically. With relative pressure measuring cells a manual offset can also be carried out.

Setup Application Units Sensor mounting correction Adjustment Damping	Sensor mounting correction Offset = -0.0003 bar 0,0001 bar	Sensor mounting correction Auto.correction Edit
--	---	---



Note:

If the current measured value is automatically accepted, it must not be falsified by medium coverage or static pressure.

With the manual position correction, the offset value can be determined by the user. Select for this purpose the function "Edit" and enter the requested value.

Save your settings with **[OK]** and move with **[ESC]** and **[->]** to the next menu item.

After the position correction is carried out, the actual measured value is corrected to 0. The corrective value appears with an inverse sign as offset value in the display.

The position correction can be repeated as often as necessary. However, if the sum of the corrective values exceeds 20 % of the nominal measuring range, then no position correction is possible.

Setup - Adjustment

CPT-2x always measures pressure independently of the process variable selected in the menu item "Application". To output the selected process variable correctly, an allocation of the output signal to 0 % and 100 % must be carried out (adjustment).

With the application "Level", the hydrostatic pressure, e.g. with full and empty vessel, is entered for adjustment. See following example:

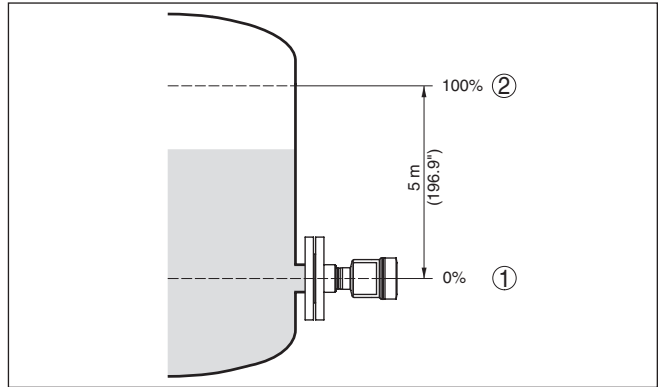

Fig. 32: Parameter adjustment example "Min./max. adjustment, level measurement"

- 1 Min. level = 0 % corresponds to 0.0 mbar
- 2 Max. level = 100 % corresponds to 490.5 mbar

If these values are not known, an adjustment with filling levels of e.g. 10 % and 90 % is also possible. By means of these settings, the real filling height is then calculated.

The actual product level during this adjustment is not important, because the min./max. adjustment is always carried out without changing the product level. These settings can be made ahead of time without the instrument having to be installed.



Note:

If the adjustment ranges are exceeded, the entered value will not be accepted. Editing can be interrupted with **[ESC]** or corrected to a value within the adjustment ranges.

For the other process variables such as e.g. process pressure, differential pressure or flow, the adjustment is performed in like manner.

Setup - Zero adjustment

Proceed as follows:

1. Select the menu item "Setup" with **[>]** and confirm with **[OK]**.
Now select with **[>]** the menu item "Zero adjustment" and confirm with **[OK]**.

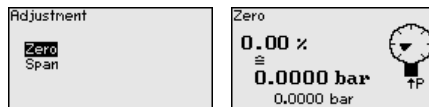

2. Edit the mbar value with **[OK]** and set the cursor to the requested position with **[>]**.

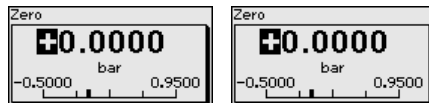

3. Set the requested mbar value with **[+]** and store with **[OK]**.

- Go with **[ESC]** and **[->]** to the span adjustment

The zero adjustment is finished.



Information:

The Zero adjustment shifts the value of the span adjustment. The span, i.e. the difference between these values, however, remains unchanged.

For an adjustment with pressure, simply enter the actual measured value indicated at the bottom of the display.

If the adjustment ranges are exceeded, the message "Outside parameter limits" appears. The editing procedure can be aborted with **[ESC]** or the displayed limit value can be accepted with **[OK]**.

Setup - Span adjustment

Proceed as follows:

- Select with **[->]** the menu item Span adjustment and confirm with **[OK]**.

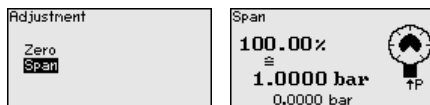

- Edit the mbar value with **[OK]** and set the cursor to the requested position with **[->]**.

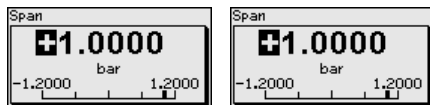

- Set the requested mbar value with **[+]** and store with **[OK]**.

For an adjustment with pressure, simply enter the actual measured value indicated at the bottom of the display.

If the adjustment ranges are exceeded, the message "Outside parameter limits" appears. The editing procedure can be aborted with **[ESC]** or the displayed limit value can be accepted with **[OK]**.

The span adjustment is finished.

Setup - Min. adjustment Level

Proceed as follows:

- Select the menu item "Setup" with **[->]** and confirm with **[OK]**. Now select with **[->]** the menu item "Adjustment", then "Min. adjustment" and confirm with **[OK]**.

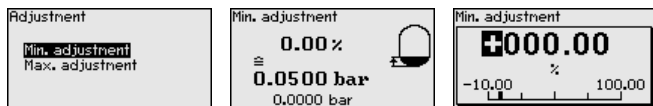

- Edit the percentage value with **[OK]** and set the cursor to the requested position with **[->]**.
- Set the requested percentage value (e.g. 10 %) with **[+]** and save with **[OK]**. The cursor jumps now to the pressure value.
- Enter the pressure value corresponding to the min. level (e.g. 0 mbar).

- Save settings with **[OK]** and move with **[ESC]** and **[->]** to the max. adjustment.

The min. adjustment is finished.

For an adjustment with filling, simply enter the actual measured value indicated at the bottom of the display.

Setup - Max. adjustment Level

Proceed as follows:

- Select with **[->]** the menu item Max. adjustment and confirm with **[OK]**.

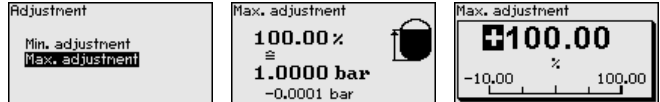

- Edit the percentage value with **[OK]** and set the cursor to the requested position with **[->]**.
- Set the requested percentage value (e.g. 90 %) with **[+]** and save with **[OK]**. The cursor jumps now to the pressure value.
- Enter the pressure value for the full vessel (e.g. 900 mbar) corresponding to the percentage value.
- Save settings with **[OK]**

The max. adjustment is finished.

For an adjustment with filling, simply enter the actual measured value indicated at the bottom of the display.

Setup - Damping

To damp process-dependent measured value fluctuations, set an integration time of 0 ... 999 s in this menu item. The increment is 0.1 s.

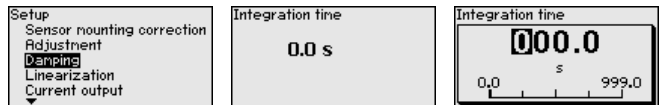

The setting in the delivery status depends on the sensor type.

Setup - Linearisation

A linearization is necessary for all vessels in which the vessel volume does not increase linearly with the level - e.g. a horizontal cylindrical or spherical tank - and the indication or output of the volume is required. Corresponding linearization curves are preprogrammed for these vessels. They represent the correlation between the level percentage and vessel volume. The linearization applies to the measured value indication and the current output.

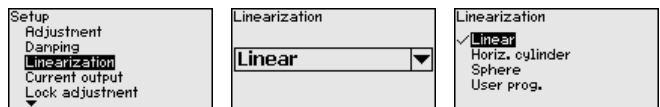

Setup - Current output (mode)

In the menu item "Current output mode" you determine the output characteristics and reaction of the current output in case of fault.

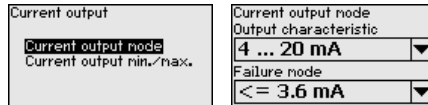

The default setting is output characteristics 4 ... 20 mA, fault mode < 3.6 mA.

Setup - Current output (Min./Max.)

In the menu item "Current output Min./Max.", you determine the reaction of the current output during operation.

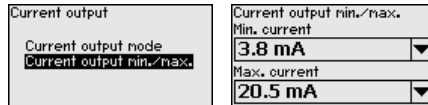

The default setting is min. current 3.8 mA and max. current 20.5 mA.

Setup - Lock adjustment

With this menu item you safeguard the sensor parameters against unauthorized or unintentional modifications.



To avoid possible errors during parameter adjustment in a non-safe environment, a verification procedure is used that enables reliable detection of parameter adjustment errors. In this procedure, safety-relevant parameters are verified before saving them in the instrument.

In addition, as a protection against unintentional or unauthorized adjustment, the instrument is locked against all parameter changes in normal operating condition.

1. Enter PIN



The instrument is shipped in locked condition. The PIN in the delivery status is "0000".

2. Character string comparison

You then have to carry out the character string comparison. This is used to check the character presentation.

Confirm if the two character strings are identical. The verification texts are provided in German and in the case of all other menu languages, in English.

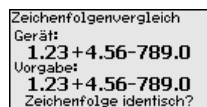

3. Serial number acknowledgement

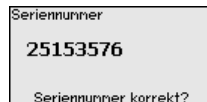

Afterwards you confirm that the serial number of your instrument was carried over correctly. This is used to check device communication.

4. Verify parameters

All safety-relevant parameters must be verified after a change:

- SIL parameter 1: Zero adjustment
- SIL parameter 2: Slave on/off
- Non-SIL parameter 1: Measured value presentation
- Non-SIL parameter 2: Display value 1, unit of the application
- Non-SIL parameter 3: Menu language
- Non-SIL parameter 4: Lighting

Confirm the modified values one after the other.

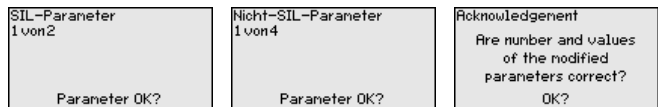

If the described process of parameter adjustment was run through completely and correctly, the instrument will be locked and hence ready for operation.



Otherwise the instrument remains in the released and hence unsafe condition.



Information:

As long as the CPT-2x is powered, the display and adjustment module remains in the actually set adjustment menu. An automatic, time-controlled reset to the measured value indication is not carried out.

Display - Language

This menu item enables the setting of the requested national language.

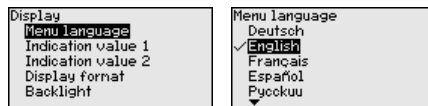

The following languages are available:

- German
- English
- French
- Spanish
- Russian
- Italian
- Dutch
- Portuguese
- Japanese
- Chinese
- Polish

- Czech
- Turkish

In delivery status, the CPT-2x is set to English.

Display - Displayed value 1 and 2

In this menu item, you define which measured value is displayed.

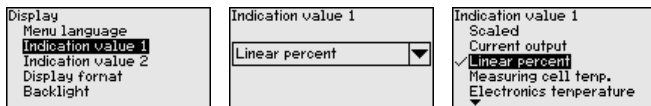

The setting in the delivery status for the display value is "Lin. percent".

Display - Display format 1 and 2

In this menu item you define the number of decimal positions with which the measured value is displayed.

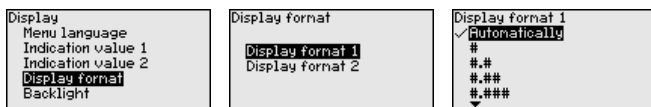

The setting in the delivery status for the display format is "Automatic".

Display - Backlight

The display and adjustment module has a backlight for the display. In this menu item you can switch on the lighting. You can find the required operating voltage in chapter "Technical data".

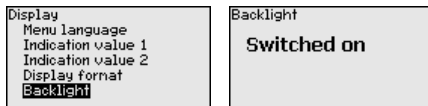

In delivery status, the lighting is switched on.

Diagnostics - Device status

In this menu item, the device status is displayed.

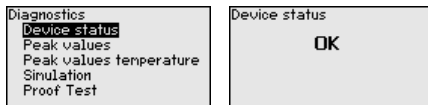

In case of error, e.g. the error code F017, e.g. the error description "Adjustment span too small" and a four digit figure are displayed for service purposes. You can find the error codes with description, reason as well as rectification in chapter "Asset Management".

Diagnostics - Peak values, pressure

The respective min. and max. measured values are saved in the sensor. The two values are displayed in menu item "Peak values, pressure".

In another window you can carry out a reset of the peak values separately.

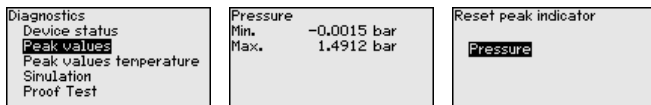

Diagnostics - Peak values, temperature

The respective min. and max. measured values of the measuring cell and the electronics temperature are stored in the sensor. In menu item "Peak value, temperature", both values are displayed.

In another window you can carry out a reset of the two peak values separately.

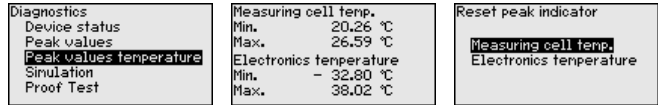

Diagnosis - Simulation

In this menu item you can simulate measured values via the current output. This allows the signal path to be tested, e.g. through downstream indicating instruments or the input card of the control system.

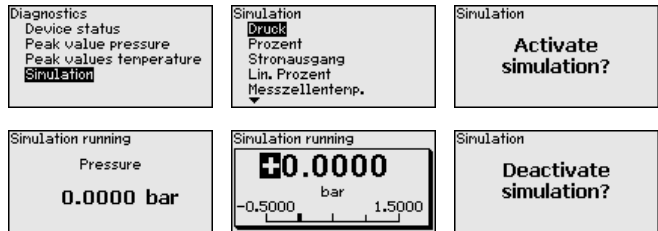

Select the requested simulation variable and set the requested value.

To deactivate the simulation, you have to push the **[ESC]** key and confirm the message "Deactivate simulation" with the **[OK]** key.



Caution:

During simulation, the simulated value is output as 4 ... 20 mA current value and digital HART signal.



Information:

Without manual deactivation, the sensor terminates the simulation automatically after 60 minutes.

Additional settings - Date/Time

In this menu item, you adjust the internal clock of the sensor. There is no adjustment for summer/winter (daylight saving) time.

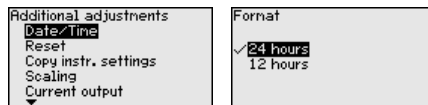

Additional settings - Reset

After a reset, certain parameter adjustments made by the user are reset.

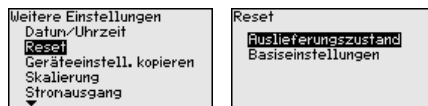

The following reset functions are available:

Delivery status: Restores the parameter settings at the time of shipment from the factory, incl. the order-specific settings. Any user-

defined linearisation curve as well as the measured value memory are deleted.

Basic settings: Resets the parameter settings, incl. special parameters, to the default values of the respective instrument. Any programmed linearisation curve as well as the measured value memory are deleted.

The following table shows the default values of the instrument. Depending on the instrument version or application, all menu items may not be available or some may be differently assigned:



The safety-relevant menu items having to do with functional safety according to IEC 61508 (Edition 2) are marked with "SIL".

Reset - Setup

Menu item	Parameter	Default value
Measurement loop name		Sensor
Application (SIL)	Application	Level
	Slave for electronic differential pressure	Deactivated
Units	Unit of measurement	mbar (with nominal measuring range ≤ 400 mbar) bar (with nominal measuring ranges ≥ 1 bar)
	Temperature unit	$^{\circ}\text{C}$
Position correction (SIL)		0.00 bar
Adjustment (SIL)	Zero/Min. adjustment	0.00 bar 0.00 %
	Span/Max. adjustment	Nominal measuring range in bar 100.00 %
Damping (SIL)	Integration time	1 s
Linearization		Linear
Current output (SIL)	Current output - Mode	Output characteristics 4 ... 20 mA Reaction when malfunctions occur ≤ 3.6 mA
	Current output - Min./Max.	3.8 mA 20.5 mA
Lock adjustment (SIL)		Last setting

Reset - Display

Menu item	Default value
Menu language	No reset
Displayed value 1	Pressure
Displayed value 2	Ceramic measuring cell: Measuring cell temperature in $^{\circ}\text{C}$ Metallic measuring cell: Electronics temperature in $^{\circ}\text{C}$

Menu item	Default value
Backlight	Switched off

Reset - Diagnosis

Menu item	Parameter	Default value
Sensor status		No reset
Peak value	Pressure	Actual measured value
	Temperature	Actual temperature values from measuring cell, electronics
Simulation	Measured value	Pressure
	Simulations	Not active
Proof test		No reset

Reset - Additional settings

Menu item	Parameter	Default value
Date/Time		No reset
Reset		No reset
Copy instrument settings		No reset
Scaling	Scaling size	Volume in l
	Scaling format	0 % corresponds to 0 l 100 % corresponds to 0 l Without decimal positions
Current output (SIL)	Current output - Meas. variable	Lin. percent - Level
	Current output - Adjustment	0 ... 100 % correspond to 4 ... 20 mA
HART mode		Address 0
Special parameter (SIL)		No reset

Additional settings - Copy instrument settings The instrument settings are copied with this function. The following functions are available:

- **Read from sensor:** Read data from sensor and store into the display and adjustment module
- **Write into sensor:** Store data from the display and adjustment module back into the sensor

The following data or settings for adjustment of the display and adjustment module are saved:

- All data of the menu "Setup" and "Display"
- In the menu "Additional adjustments" the items "Reset, Date/Time"
- The user-programmable linearization curve



The copied data are permanently saved in an EEPROM memory in the display and adjustment module and remain there even in case of power failure. From there, they can be written into one or more sensors or kept as backup for a possible electronics exchange.



Note:

Before the data are saved in the sensor, a safety check is carried out to determine if the data match the sensor. In the process the sensor type of the source data as well as the target sensor are displayed. If the data do not match, a fault message is outputted or the function is blocked. The data are saved only after release.

Additional settings - Scaling (1)

In menu item "Scaling" you define the scaling variable and the scaling unit for the level value on the display, e.g. volume in l.

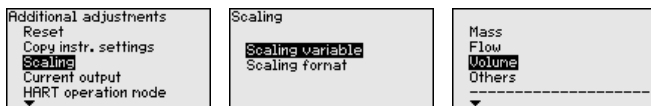

Additional settings - Scaling (2)

In menu item "Scaling (2)" you define the scaling format on the display and the scaling of the measured level value for 0 % and 100 %.

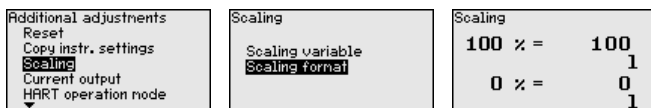

Additional settings - Current output

In the menu items "Current output" you determine the properties of the current output.

On instruments with integrated additional current output, the properties for each current output are adjusted individually. The following descriptions apply to both current outputs.



The additional current output cannot be used as an output in the sense of a safety-instrumented application (SIL).

Additional settings - Current output 1 and 2 (size)

In menu item "Current output, variable" you specify which measured variable the current output refers to.



For instruments with SIL qualification, the selection is limited to lin. percent.

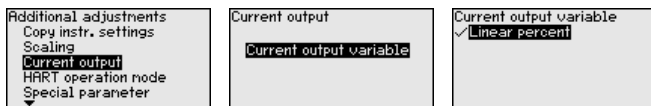

Additional adjustments - HART mode

The sensor is preset to the HART mode "Analogue current output".

SIL For instruments with SIL qualification, this parameter cannot be modified.

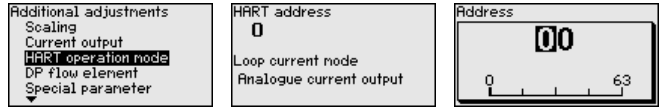

The default setting is "Analogue current output" and the address 00.

Additional settings - Special parameters

In this menu item you gain access to the protected area where you can enter special parameters. In exceptional cases, individual parameters can be modified in order to adapt the sensor to special requirements.

Change the settings of the special parameters only after having contacted our service staff.

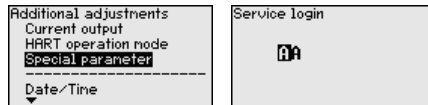

Info - Instrument name

In this menu item, you can read out the instrument name and the instrument serial number:

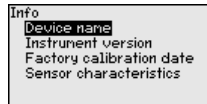

Info - Instrument version

In this menu item, the hardware and software version of the sensor is displayed.

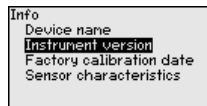

Info - Factory calibration date

In this menu item, the date of factory calibration of the sensor as well as the date of the last change of sensor parameters are displayed via the display and adjustment module or via the PC.

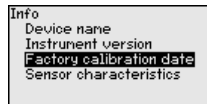

Info - Sensor characteristics

In this menu item, the features of the sensor such as approval, process fitting, seal, measuring range, electronics, housing and others are displayed.

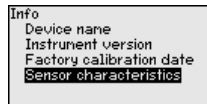

7.5 Saving the parameterisation data

On paper

We recommended writing down the adjustment data, e.g. in this operating instructions manual, and archiving them afterwards. They are thus available for multiple use or service purposes.

In the display and adjustment module

If the instrument is equipped with a display and adjustment module, the parameter adjustment data can be saved therein. The procedure is described in menu item "*Copy device settings*".

8 Setup with PACTware

8.1 Connect the PC

Connecting the PC to the signal cable

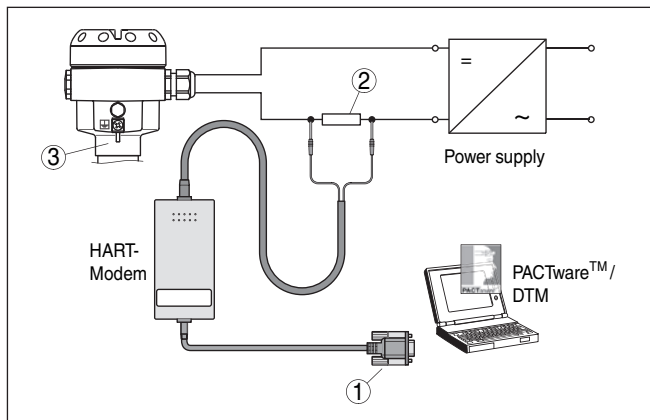

Fig. 33: Connecting the PC to the signal cable

- 1 RS232 connection
- 2 HART resistor 250 Ω
- 3 CPT-2x

Necessary components:

- CPT-2x
- PC with PACTware and suitable WIKA DTM
- HART modem
- HART resistance approx. 250 Ω
- Power supply unit



Note:

For power supply units with integrated HART resistance (inner resistance approx. 250 Ω), there is no additional external resistance necessary. Standard Ex separators are often provided with a sufficiently high current limitation resistance. In such cases, the modem can be connected in parallel to the 4 ... 20 mA cable.

8.2 Parameter adjustment

The further setup steps with detailed descriptions can be found in the online help of PACTware and the DTMs.



Note:

Keep in mind that for the setup of model CPT-2x, the current version of the DTM-Collection must be used.

The latest DTM Collection and PACTware version can be downloaded free of charge via the Internet.

8.3 Saving the parameterisation data

We recommend documenting or saving the parameterisation data via PACTware. That way the data are available for multiple use or service purposes.

9 Diagnosis, asset management and service

9.1 Maintenance

Maintenance

If the device is used properly, no special maintenance is required in normal operation.

In some applications, product buildup on the diaphragm can influence the measuring result. Depending on the sensor and application, take precautions to ensure that heavy buildup, and especially a hardening thereof, is avoided.

Proof test

To identify possible undetected, dangerous failures, the safety function of the instrument must be checked in adequate intervals by a proof test.



During the function test, the safety function must be treated as unsafe. Keep in mind that the function test influences downstream connected devices.

If one of the tests proves negative, the entire measuring system must be switched out of service and the process held in a safe state by means of other measures.

You can find detailed information on the proof test in the Safety Manual (SIL).

9.2 Cleaning - hygienic connection with compression nut

Overview

The hygienic connection with compression nut can be disassembled and the diaphragm cleaned.

The following graphic shows the structure:

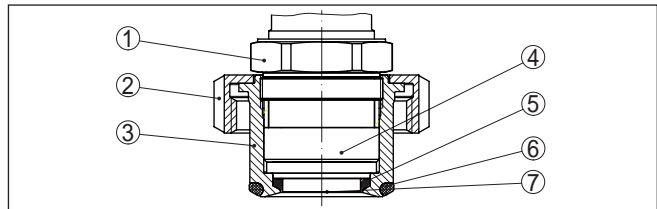

Fig. 34: CPT-2x, structure of the hygienic connection with compression nut

- 1 Hexagon
- 2 Compression nut
- 3 Process fitting
- 4 Process module
- 5 Form seal for the measuring cell
- 6 O-ring seal for the process fitting
- 7 Diaphragm

Procedure

To do so, proceed as follows:

1. Loosen compression nut and remove the pressure transmitter from the welded socket
2. Remove the O-ring seal for the process fitting

3. Clean the diaphragm with brass brush and cleaning detergent
4. Loosen the hexagon and remove the process component from the process fitting
5. Remove the form seal for the measuring cell and remove it by a new one
6. Screw the process component into the process fitting, tighten the hexagon (wrench size see chapter "*Dimensions*", max. torque see chapter "*Technical data*")
7. Insert new O-ring seal for the process fitting
8. Install the process pressure transmitter in the welded socket, tighten compression nut

The cleaning is finished.

The pressure transmitter is directly ready for operation, a fresh adjustment is not required.

9.3 Diagnosis memory

The instrument has several memories available for diagnostic purposes. The data remain there even in case of voltage interruption.

Measured value memory

Up to 100,000 measured values can be stored in the sensor in a ring memory. Each entry contains date/time as well as the respective measured value.

Depending on the instrument version, values that can be stored are for example:

- Level
- Process pressure
- Differential pressure
- Static pressure
- Percentage value
- Scaled values
- Current output
- Lin. percent
- Measuring cell temperature
- Electronics temperature

When the instrument is shipped, the measured value memory is active and stores pressure value and measuring cell temperature every 10 s, with electronic differential pressure also the static pressure.

The requested values and recording conditions are set via a PC with PACTware/DTM or the control system with EDD. Data are thus read out and also reset.

Event memory

Up to 500 events are automatically stored with a time stamp in the sensor (non-deletable). Each entry contains date/time, event type, event description and value. Event types are for example:

- Modification of a parameter
- Switch-on and switch-off times
- Status messages (according to NE 107)
- Error messages (according to NE 107)

The data are read out via a PC with PACTware/DTM or the control system with EDD.

9.4 Asset Management function

The instrument features self-monitoring and diagnostics according to NE 107 and VDI/VDE 2650. In addition to the status messages in the following tables, detailed error messages are available under menu item "Diagnostics" via the display and adjustment module, PACTware/DTM and EDD.

Status messages

The status messages are divided into the following categories:

- Failure
- Function check
- Out of specification
- Maintenance requirement

and explained by pictographs:

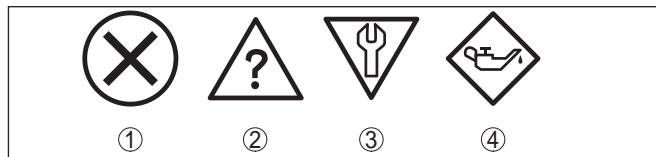

Fig. 35: Pictographs of the status messages

- 1 Failure - red
- 2 Out of specification - yellow
- 3 Function check - orange
- 4 Maintenance - blue

Failure: Due to a malfunction in the instrument, a fault message is output.

This status message is always active. It cannot be deactivated by the user.

Function check: The instrument is being worked on, the measured value is temporarily invalid (for example during simulation).

This status message is active by default. It can be deactivated by the user via PACTware/DTM or EDD.

Out of specification: The measured value is unreliable because an instrument specification was exceeded (e.g. electronics temperature).

This status message is inactive by default. It can be activated by the user via PACTware/DTM or EDD.

Maintenance: Due to external influences, the instrument function is limited. The measurement is affected, but the measured value is still valid. Plan in maintenance for the instrument because a failure is expected in the near future (e.g. due to buildup).

This status message is active by default. It can be deactivated by the user via PACTware/DTM or EDD.

Failure

Code Text message	Cause	Rectification	DevSpec State in CMD 48
F013 No valid measured value available	<ul style="list-style-type: none"> ● Gauge pressure or low pressure ● Measuring cell defective 	<ul style="list-style-type: none"> ● Exchange measuring cell ● Send instrument for repair 	Bit 0 of Byte 0 ... 5
F017 Adjustment span too small	<ul style="list-style-type: none"> ● Adjustment not within specification 	<ul style="list-style-type: none"> ● Change the adjustment according to the limit values 	Bit 1 of Byte 0 ... 5
F025 Error in the linearisation table	<ul style="list-style-type: none"> ● Index markers are not continuously rising, for example illogical value pairs 	<ul style="list-style-type: none"> ● Check linearisation table ● Delete table/Create new 	Bit 2 of Byte 0 ... 5
F036 no operable sensor software	<ul style="list-style-type: none"> ● Failed or interrupted software update 	<ul style="list-style-type: none"> ● Repeat software update ● Check electronics version ● Exchanging the electronics ● Send instrument for repair 	Bit 3 of Byte 0 ... 5
F040 Error in the electronics	<ul style="list-style-type: none"> ● Hardware defect 	<ul style="list-style-type: none"> ● Exchanging the electronics ● Send instrument for repair 	Bit 4 of Byte 0 ... 5
F041 Communication error	<ul style="list-style-type: none"> ● No connection to the sensor electronics 	<ul style="list-style-type: none"> ● Check connection between sensor and main electronics (with separate version) 	Bit 5 of Byte 0 ... 5
F042 Communication error Slave	<ul style="list-style-type: none"> ● No connection to the Slave 	<ul style="list-style-type: none"> ● Check connection between Master and Slave 	Bit 15 of Byte 0 ... 5
F080 General software error	<ul style="list-style-type: none"> ● General software error 	<ul style="list-style-type: none"> ● Disconnect operating voltage briefly 	Bit 6 of Byte 0 ... 5
F105 Measured value is determined	<ul style="list-style-type: none"> ● The instrument is still in the start phase, the measured value could not yet be determined 	<ul style="list-style-type: none"> ● Wait for the end of the switch-on phase 	Bit 7 of Byte 0 ... 5
F125 Impermissible electronics temperature	<ul style="list-style-type: none"> ● Electronics temperature in the non-specified range 	<ul style="list-style-type: none"> ● Check ambient temperature ● Insulate electronics ● Use instrument with higher temperature range 	Bit 9 of Byte 0 ... 5
F260 Error in the calibration	<ul style="list-style-type: none"> ● Error in the calibration carried out in the factory ● Error in the EEPROM 	<ul style="list-style-type: none"> ● Exchanging the electronics ● Send instrument for repair 	Bit 10 of Byte 0 ... 5
F261 Error in the instrument settings	<ul style="list-style-type: none"> ● Error during setup ● Error when carrying out a reset 	<ul style="list-style-type: none"> ● Repeat setup ● Repeat reset 	Bit 11 of Byte 0 ... 5

Code Text message	Cause	Rectification	DevSpec State in CMD 48
F264 Installation/Setup error	<ul style="list-style-type: none"> ● Inconsistent settings (e.g.: distance, adjustment units with application process pressure) for selected application ● Invalid sensor configuration (e.g.: application electronic differential pressure with connected differential pressure measuring cell) 	<ul style="list-style-type: none"> ● Modify settings ● Modify connected sensor configuration or application 	Bit 12 of Byte 0 ... 5
F265 Measurement function disturbed	<ul style="list-style-type: none"> ● Sensor no longer carries out a measurement 	<ul style="list-style-type: none"> ● Carry out a reset ● Disconnect operating voltage briefly 	Bit 13 of Byte 0 ... 5
F266 Impermissible voltage supply	<ul style="list-style-type: none"> ● Operating voltage below specified range 	<ul style="list-style-type: none"> ● Check electrical connection ● If necessary, increase operating voltage 	Bit 14 of Byte 0 ... 5

Tab. 5: Error codes and text messages, information on causes as well as corrective measures

Function check

Code Text message	Cause	Rectification	DevSpec State in CMD 48
C700 Simulation active	<ul style="list-style-type: none"> ● A simulation is active 	<ul style="list-style-type: none"> ● Finish simulation ● Wait for the automatic end after 60 mins. 	"Simulation Active" in "Standardized Status 0"
C701 Parameter verification	<ul style="list-style-type: none"> ● Parameter verification was interrupted 	<ul style="list-style-type: none"> ● Finish parameter verification 	Bit 13 of Byte 14 ... 24

Tab. 6: Error codes and text messages, information on causes as well as corrective measures

Out of specification

Code Text message	Cause	Rectification	DevSpec State in CMD 48
S600 Impermissible electronics temperature	<ul style="list-style-type: none"> ● Temperature of the electronics in the non-specified range 	<ul style="list-style-type: none"> ● Check ambient temperature ● Insulate electronics 	Bit 23-0 of Byte 14 ... 24
S603 Impermissible operating voltage	<ul style="list-style-type: none"> ● Operating voltage below specified range 	<ul style="list-style-type: none"> ● Check electrical connection ● If necessary, increase operating voltage 	Bit 23-1 of Byte 14 ... 24
S605 Impermissible pressure value	<ul style="list-style-type: none"> ● Measured process pressure below or above the adjustment range 	<ul style="list-style-type: none"> ● Check nominal measuring range of the instrument ● If necessary, use an instrument with a higher measuring range 	Bit 23-2 of Byte 14 ... 24

Tab. 7: Error codes and text messages, information on causes as well as corrective measures

Maintenance

Code Text message	Cause	Rectification	DevSpec State in CMD 48
M500 Error in the delivery status	<ul style="list-style-type: none"> The data could not be restored during the reset to delivery status 	<ul style="list-style-type: none"> Repeat reset Load XML file with sensor data into the sensor 	Bit 0 of Byte 14 ... 24
M501 Error in the non-active linearisation table	<ul style="list-style-type: none"> Index markers are not continuously rising, for example illogical value pairs 	<ul style="list-style-type: none"> Check linearisation table Delete table/Create new 	Bit 1 of Byte 14 ... 24
M502 Error in the event memory	<ul style="list-style-type: none"> Hardware error EEPROM 	<ul style="list-style-type: none"> Exchanging the electronics Send instrument for repair 	Bit 2 of Byte 14 ... 24
M504 Error at a device interface	<ul style="list-style-type: none"> Hardware defect 	<ul style="list-style-type: none"> Exchanging the electronics Send instrument for repair 	Bit 3 of Byte 14 ... 24
M507 Error in the instrument settings	<ul style="list-style-type: none"> Error during setup Error when carrying out a reset 	<ul style="list-style-type: none"> Carry out reset and repeat setup 	Bit 4 of Byte 14 ... 24

Tab. 8: Error codes and text messages, information on causes as well as corrective measures

9.5 Rectify faults

Reaction when malfunction occurs

The operator of the system is responsible for taking suitable measures to rectify faults.

Fault rectification

The first measures are:

- Evaluation of fault messages
- Checking the output signal
- Treatment of measurement errors

A smartphone/tablet with the VEGA Tools app or a PC/notebook with the software PACTware and the suitable DTM offer you further comprehensive diagnostic possibilities. In many cases, the causes can be determined in this way and the faults eliminated.

4 ... 20 mA signal

Connect a multimeter in the suitable measuring range according to the wiring plan. The following table describes possible errors in the current signal and helps to eliminate them:

Error	Cause	Rectification
4 ... 20 mA signal not stable	<ul style="list-style-type: none"> Fluctuating measured value 	<ul style="list-style-type: none"> Set damping
4 ... 20 mA signal missing	<ul style="list-style-type: none"> Electrical connection faulty 	<ul style="list-style-type: none"> Check connection, correct, if necessary
	<ul style="list-style-type: none"> Voltage supply missing 	<ul style="list-style-type: none"> Check cables for breaks; repair if necessary
	<ul style="list-style-type: none"> Operating voltage too low, load resistance too high 	<ul style="list-style-type: none"> Check, adapt if necessary

Error	Cause	Rectification
Current signal greater than 22 mA, less than 3.6 mA	<ul style="list-style-type: none"> ● Sensor electronics defective 	<ul style="list-style-type: none"> ● Exchange the instrument or send it in for repair

Reaction after fault rectification

Depending on the reason for the fault and the measures taken, the steps described in chapter "Setup" must be carried out again or must be checked for plausibility and completeness.

9.6 Exchange process module on version IP 68 (25 bar)

On version IP 68 (25 bar), the user can exchange the process module on site. Connection cable and external housing can be kept.

Required tools:

- Hexagon key wrench, size 2



Caution:

The exchange may only be carried out in the complete absence of line voltage.



In Ex applications, only a replacement part with appropriate Ex approval may be used.



Caution:

During exchange, protect the inner side of the parts against contamination and moisture.

Proceed as follows when carrying out the exchange:

1. Loosen the fixing screw with the hexagon key wrench
2. Carefully detach the cable assembly from the process module

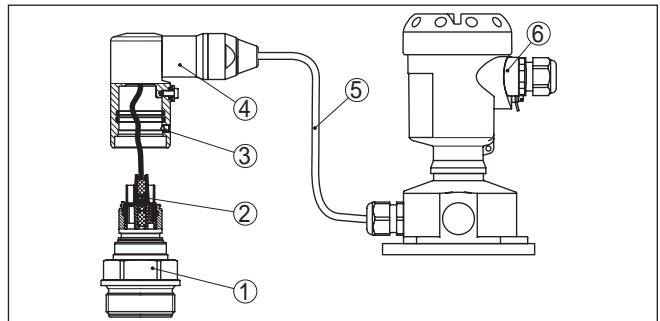

Fig. 36: CPT-2x in IP 68 version, 25 bar and lateral cable outlet, external housing

- 1 Process module
- 2 Plug connector
- 3 Fixing screw
- 4 Cable assembly
- 5 Connection cable
- 6 External housing

3. Loosen the plug connector

4. Mount the new process module on the measuring point
5. Plug the connector back in
6. Mount the cable assembly on the process module and turn it to the desired position
7. Tighten the fixing screw with the hexagon key wrench

The exchange is finished.

9.7 Instrument repair

You can find information for a return shipment under "Service" on our local website.

If a repair is necessary, please proceed as follows:

- Complete one form for each instrument
- If necessary, state a contamination
- Clean the instrument and pack it damage-proof
- Attach the completed form and possibly also a safety data sheet to the instrument

10 Dismount

10.1 Dismounting steps

**Warning:**

Before dismantling, be aware of dangerous process conditions such as e.g. pressure in the vessel or pipeline, high temperatures, corrosive or toxic products etc.

Take note of chapters "*Mounting*" and "*Connecting to voltage supply*" and carry out the listed steps in reverse order.

10.2 Disposal

The instrument consists of materials which can be recycled by specialised recycling companies. We use recyclable materials and have designed the electronics to be easily separable.

WEEE directive

The instrument does not fall in the scope of the EU WEEE directive. Article 2 of this Directive exempts electrical and electronic equipment from this requirement if it is part of another instrument that does not fall in the scope of the Directive. These include stationary industrial plants.

Pass the instrument directly on to a specialised recycling company and do not use the municipal collecting points.

If you have no way to dispose of the old instrument properly, please contact us concerning return and disposal.

11 Supplement

11.1 Technical data

Note for approved instruments

The technical data in the respective safety instructions are valid for approved instruments (e.g. with Ex approval). These data can differ from the data listed herein, for example regarding the process conditions or the voltage supply.

Materials and weights

Materials, wetted parts

Process fitting	316L, PVDF, Alloy C22 (2.4602), Alloy C276 (2.4819), Duplex steel (1.4462), Titanium Grade 2
Diaphragm	Sapphire-ceramic® (> 99.9 % Al ₂ O ₃ ceramic)
Joining material measuring cell	Glass (with double and form seal, non-wetted parts)
Measuring cell seal	
– Standard (O-ring seal)	FKM (VP2/A, A+P 70.16), EPDM (A+P 70.10-02), FFKM (Kalrez 6375, Perlast G75S, Perlast G75B)
– Hygienic fitting with compression nut (form seal)	FKM (ET 6067), EPDM (EPDM 7076), FFKM (Chemraz 535), FEPM (Fluoraz SD890)
Seal for process fitting (in the scope of delivery)	
– Thread G½ (EN 837), G1½ (DIN 3852-A)	Klingersil C-4400
– Thread M44 x 1.25 (DIN 13), M30 x 1.5	FKM, FFKM, EPDM
– Hygienic connection with compression nut	FKM, EPDM, FFKM, FEPM
Surface quality, hygienic fittings, typ.	
– Process fitting	R _a < 0.8 µm
– Diaphragm	R _a < 0.5 µm

Materials, non-wetted parts

Sensor housing

– Housing	Plastic PBT (Polyester), Aluminium AlSi10Mg (powder-coated, basis: Polyester), 316L
– Cable gland	PA, stainless steel, brass
– Cable gland: Seal, closure	NBR, PA
– Seal, housing lid	Silicone SI 850 R, NBR silicone-free
– Inspection window housing cover	Polycarbonate (UL-746-C listed), glass ¹⁾
– Ground terminal	316L
External housing - deviating materials	
– Housing and socket	Plastic PBT (Polyester), 316L
– Socket seal	EPDM

¹⁾ Glass with Aluminium and stainless steel precision casting housing

– Seal below wall mounting plate ²⁾	EPDM
– Inspection window housing cover	Polycarbonate (UL-746-C listed)
Ground terminal	316Ti/316L
Connection cable with IP 68 (25 bar) ³⁾	
– Cable cover	PE, PUR
– Type label support on cable	PE hard
Connection cable with IP 68 (1 bar) ⁴⁾	PE, PUR

Weights

Total weight CPT-2x	approx. 0.8 ... 8 kg (1.764 ... 17.64 lbs), depending on process fitting and housing
---------------------	--

Torques

Max. torque for process fitting

– G½, G¾	30 Nm (22.13 lbf ft)
– Fittings according to 3A with exchangeable sealing	20 Nm (14.75 lbf ft)
– Hygienic fitting with compression nut (hexagon)	40 Nm (29.50 lbf ft)
– G1, M30 x 1.5	50 Nm (36.88 lbf ft)
– G1 for PASVE	100 Nm (73.76 lbf ft)
– G1½	200 Nm (147.5 lbf ft)

Max. torque for screws

– PMC 1", PMC 1¼"	2 Nm (1.475 lbf ft)
– PMC 1½"	5 Nm (3.688 lbf ft)

Max. torque for NPT cable glands and Conduit tubes

– Plastic housing	10 Nm (7.376 lbf ft)
– Aluminium/Stainless steel housing	50 Nm (36.88 lbf ft)

Input variable

The specifications are only an overview and refer to the measuring cell. Limitations due to the material and version of the process fitting as well as the selected pressure type are possible. The specifications on the nameplate apply.

Nominal measuring ranges and overload capability in bar/kPa

Nominal range	Overload capability	
	Maximum pressure	Minimum pressure
Gauge pressure		
0 ... +0.025 bar/0 ... +2.5 kPa (only for measuring cell ø 28 mm)	+5 bar/+500 kPa	-0.05 bar/-5 kPa

²⁾ Only for 316L with 3A approval

³⁾ Between transmitter and external electronics housing.

⁴⁾ Fix connected to the sensor.

Nominal range	Overload capability	
	Maximum pressure	Minimum pressure
0 ... +0.1 bar/0 ... +10 kPa	+15 bar/+1500 kPa	-0.2 bar/-20 kPa
0 ... +0.4 bar/0 ... +40 kPa	+30 bar/+3000 kPa	-0.8 bar/-80 kPa
0 ... +1 bar/0 ... +100 kPa	+35 bar/+3500 kPa	-1 bar/-100 kPa
0 ... +2.5 bar/0 ... +250 kPa	+50 bar/+5000 kPa	-1 bar/-100 kPa
0 ... +5 bar/0 ... +500 kPa	+65 bar/+6500 kPa	-1 bar/-100 kPa
0 ... +10 bar/0 ... +1000 kPa	+90 bar/+9000 kPa	-1 bar/-100 kPa
0 ... +25 bar/0 ... +2500 kPa	+125 bar/+12500 kPa	-1 bar/-100 kPa
0 ... +60 bar/0 ... +6000 kPa	+200 bar/+20000 kPa	-1 bar/-100 kPa
0 ... +100 bar/0 ... +10000 kPa (only for measuring cell ø 28 mm)	+200 bar/+20000 kPa	-1 bar/-100 kPa
-1 ... 0 bar/-100 ... 0 kPa	+35 bar/+3500 kPa	-1 bar/-100 kPa
-1 ... +1.5 bar/-100 ... +150 kPa	+40 bar/+4000 kPa	-1 bar/-100 kPa
-1 ... +10 bar/-100 ... +1000 kPa	+90 bar/+9000 kPa	-1 bar/-100 kPa
-1 ... +25 bar/-100 ... +2500 kPa	+125 bar/+12500 kPa	-1 bar/-100 kPa
-1 ... +60 bar/-100 ... +6000 kPa	+200 bar/+20000 kPa	-1 bar/-100 kPa
-1 ... +100 bar/-100 ... +10000 kPa (only for measuring cell ø 28 mm)	+200 bar/+20000 kPa	-1 bar/-100 kPa
-0.025 ... +0.025 bar/-2.5 ... +2.5 kPa	+5 bar/+500 kPa	-0.05 bar/-5 kPa
-0.05 ... +0.05 bar/-5 ... +5 kPa	+15 bar/+1500 kPa	-0.2 bar/-20 kPa
-0.2 ... +0.2 bar/-20 ... +20 kPa	+20 bar/+2000 kPa	-0.4 bar/-40 kPa
-0.5 ... +0.5 bar/-50 ... +50 kPa	+35 bar/+3500 kPa	-1 bar/-100 kPa
Absolute pressure		
0 ... 0.1 bar/0 ... 10 kPa	15 bar/1500 kPa	0 bar abs.
0 ... 1 bar/0 ... 100 kPa	35 bar/3500 kPa	0 bar abs.
0 ... 2.5 bar/0 ... 250 kPa	50 bar/5000 kPa	0 bar abs.
0 ... +5 bar/0 ... +500 kPa	65 bar/+6500 kPa	0 bar abs.
0 ... 10 bar/0 ... 1000 kPa	90 bar/9000 kPa	0 bar abs.
0 ... 25 bar/0 ... 2500 kPa	125 bar/12500 kPa	0 bar abs.
0 ... 60 bar/0 ... 6000 kPa	200 bar/20000 kPa	0 bar abs.
0 ... 100 bar/0 ... +10000 kPa (only for measuring cell ø 28 mm)	200 bar/20000 kPa	0 bar abs.

Nominal measuring ranges and overload capacity in psi

Nominal range	Overload capability	
	Maximum pressure	Minimum pressure
Gauge pressure		

Zero/Span adjustment:

– Zero	-20 ... +95 %
– Span	-120 ... +120 %
– Difference between zero and span	max. 120 % of the nominal range
Max. permissible Turn Down	Unlimited (recommended 20 : 1)
Max. permissible turn down with SIL applications	10 : 1

Switch-on phaseRun-up time with operating voltage U_B

– ≥ 12 V DC	≤ 9 s
– < 12 V DC	≤ 22 s
Starting current (for run-up time)	≤ 3.6 mA

Output variable

For details on the operating voltage see chapter "Voltage supply"

Output signal	4 ... 20 mA/HART
Range of the output signal	3.8 ... 20.5 mA/HART (default setting)
Fulfilled HART specification	7.3
Signal resolution	0.3 μ A
Fault signal, current output (adjustable)	≥ 21 mA, ≤ 3.6 mA, last valid measured value ⁵⁾
Max. output current	21.5 mA
Load	See load resistance under Power supply
Starting current	≤ 10 mA for 5 ms after switching on, ≤ 3.6 mA
Damping (63 % of the input variable), adjustable	0 ... 999 s
HART output values according to HART 7 (default setting) ⁶⁾	
– First HART value (PV)	Linear percentage value
– Second HART value (SV)	Measuring cell temperature (ceramic measuring cell)
– Third HART value (TV)	Pressure
– Fourth HART value (QV)	Electronics temperature

Dynamic behaviour output

Dynamic characteristics depending on medium and temperature

⁵⁾ Last valid measured value not possible with SIL.

⁶⁾ The output values can be assigned individually.

Determination of characteristics	Limit point adjustment according to IEC 61298-2
Characteristic curve	Linear
Reference installation position	upright, diaphragm points downward
Influence of the installation position	< 0.2 mbar/20 Pa (0.003 psig)
Deviation in the current output due to strong, high-frequency electromagnetic fields acc. to EN 61326-1	< $\pm 150 \mu\text{A}$

Deviation (according to IEC 60770)

Applies to the **digital** signal output (HART, Profibus PA, Foundation Fieldbus) as well as to the **analogue** current output 4 ... 20 mA and refers to the set span. Turn down (TD) is the ratio "nominal measuring range/set span".

The specified values correspond to the value F_{KI} in chapter "Calculation of the total deviation".

Accuracy class	Non-linearity, hysteresis and repeatability with TD 1 : 1 up to 5 : 1	Non-linearity, hysteresis and repeatability with 5 : 1
0.05 %	< 0.05 %	< 0.01 % x TD
0.1 %	< 0.1 %	< 0.02 % x TD
0.2 %	< 0.2 %	< 0.04 % x TD

Influence of the medium or ambient temperature

Thermal change zero signal and output span through product temperature

Applies to the **digital** signal output (HART, Profibus PA, Foundation Fieldbus) as well as to the **analogue** current output 4 ... 20 mA and refers to the set span. Turn down (TD) is the ratio "nominal measuring range/set span".

The thermal change of the zero signal and output span corresponds to the value F_T in chapter "Calculation of the total deviation (according to DIN 16086)".

Piezoresistive/strain gauge measuring cell

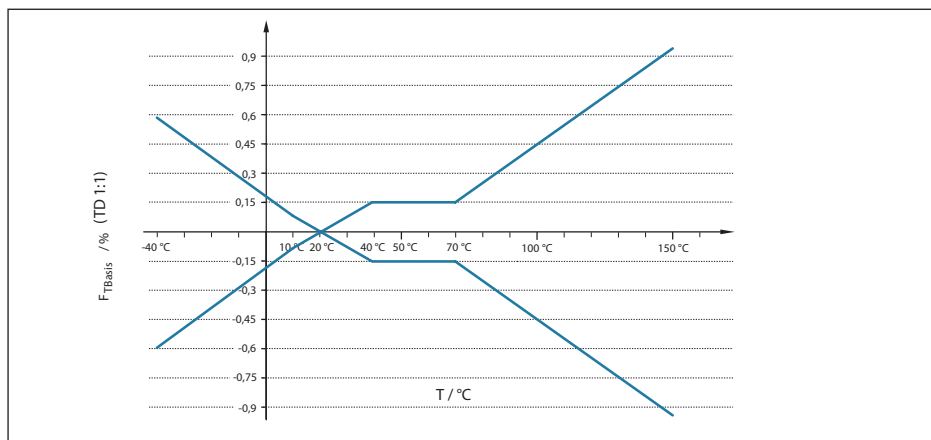

Fig. 38: Basic temperature error F_{TBasis} at TD 1 : 1

The basic temperature error in % from the above graphic can increase due to the additional factors such as accuracy class (factor FMZ) and Turn Down (factor FTD). The additional factors are listed in the following tables.

Additional factor through accuracy class

Accuracy class	0.075 %, 0.1 %	0.2 %
Factor FMZ	1	3

Additional factor through Turn Down

The additional factor FTD through Turn down is calculated according to the following formula:

$$F_{TD} = 0.5 \times TD + 0.5$$

In the table, example values for typical Turn downs are listed.

Turn Down	TD 1 : 1	TD 2.5 : 1	TD 5 : 1	TD 10 : 1	TD 20 : 1
Factor FTD	1	1.75	3	5.5	10.5

Ceramic/Metal measuring cell - Standard

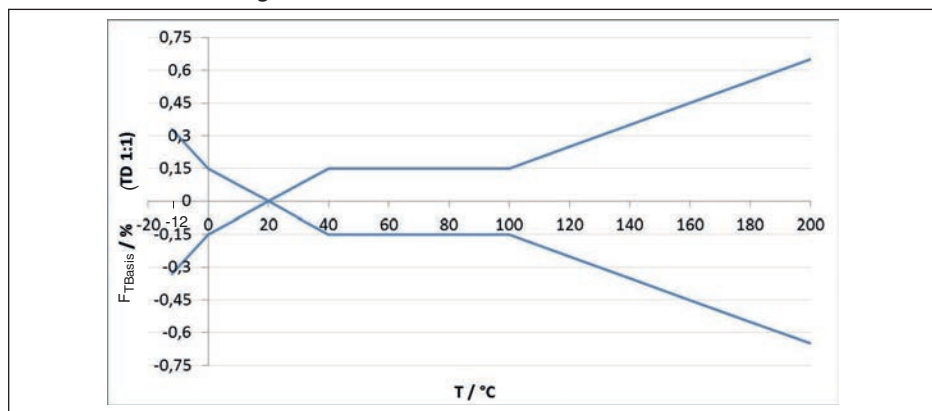

Fig. 39: Basic temperature error F_{TBasis} at TD 1 : 1

The basic temperature error in % from the above graphic can increase due to the additional factors, depending on the measuring cell version (factor FMZ) and the Turn Down (factor FTD). The additional factors are listed in the following tables.

Additional factor through measuring cell version

Measuring cell version	Measuring cell - Standard	
	0.075 %, 0.1 %	0.2 %
Factor FMZ	1	3

Additional factor through Turn Down

The additional factor FTD through Turn down is calculated according to the following formula:

$$F_{TD} = 0.5 \times TD + 0.5$$

In the table, example values for typical Turn downs are listed.

Turn Down	TD 1 : 1	TD 2.5 : 1	TD 5 : 1	TD 10 : 1	TD 20 : 1
Factor FTD	1	1.75	3	5.5	10.5

Thermal change current output through ambient temperature

Applies also to the **analogue** 4 ... 20 mA current output and refers to the set span.

Thermal change, current output < 0.05 %/10 K, max. < 0.15 %, each with -40 ... +80 °C (-40 ... +176 °F)

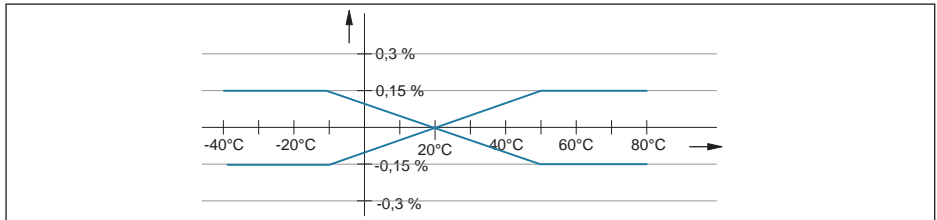

Fig. 40: Thermal change, current output

Long-term stability (according to DIN 16086)

Applies to the respective **digital** signal output (e.g. HART, Profibus PA) as well as to **analogue** current output 4 ... 20 mA under reference conditions. Specifications refer to the set span. Turn down (TD) is the ratio nominal measuring range/set span.

Long-term stability zero signal and output span

Time period	Measuring cell ø 28 mm		Measuring cell ø 17.5 mm	
	All measuring ranges	Measuring range 0 ... +0.025 bar (0 ... +2.5 kPa)	All process fittings	Process fitting G½ (ISO 228-1)
One year	< 0.05 % x TD	< 0.1 % x TD	< 0.1 % x TD	< 0.25 % x TD
Five years	< 0.1 % x TD	< 0.2 % x TD	< 0.2 % x TD	< 0.5 % x TD
Ten years	< 0.2 % x TD	< 0.4 % x TD	< 0.4 % x TD	< 1 % x TD

Ambient conditions

Version	Ambient temperature	Storage and transport temperature
Standard version	-40 ... +80 °C (-40 ... +176 °F)	-60 ... +80 °C (-76 ... +176 °F)
Version IP 66/IP 68 (1 bar)	-20 ... +80 °C (-4 ... +176 °F)	-20 ... +80 °C (-4 ... +176 °F)
Version IP 68 (25 bar) with connection cable PUR	-20 ... +80 °C (-4 ... +176 °F)	-20 ... +80 °C (-4 ... +176 °F)
Version IP 68 (25 bar), connection cable PE	-20 ... +60 °C (-4 ... +140 °F)	-20 ... +60 °C (-4 ... +140 °F)

Process conditions

Process temperature⁷⁾

Measuring cell seal		Sensor version	
		Standard	Extended temperature range ⁸⁾
FKM	VP2/A	-20 ... +130 °C (-4 ... +266 °F)	-20 ... +150 °C (-4 ... +302 °F)
	A+P 70.16	-40 ... +130 °C (-40 ... +266 °F)	-
	Endura V91A	-40 ... +130 °C (-40 ... +266 °F)	-40 ... +150 °C (-40 ... +302 °F)
	ET 7067	-20 ... +130 °C (-4 ... +266 °F)	-
	V70SW	-	-10 ... +150 °C (14 ... +302 °F)
EPDM	A+P 70.10-02	-40 ... +130 °C (-40 ... +266 °F)	-40 ... +150 °C (-40 ... +302 °F)
	ET 7056	-40 ... +130 °C (-40 ... +266 °F)	-
	E70Q	-	-40 ... +150 °C (-40 ... +302 °F)
	Fluoraz SD890	-5 ... +130 °C (-22 ... +266 °F)	-
FFKM	Kalrez 6375	-20 ... +130 °C (-4 ... +266 °F)	-20 ... +150 °C (-4 ... +302 °F)
	Perlast G75S	-15 ... +130 °C (-4 ... +266 °F)	-15 ... +150 °C (5 ... +302 °F)
	Perlast G75B	-15 ... +130 °C (-4 ... +266 °F)	-15 ... +150 °C (5 ... +302 °F)
	Perlast G92E	-15 ... +130 °C (-4 ... +266 °F)	-15 ... +150 °C (5 ... +302 °F)
	Chemraz 535	-30 ... +130 °C (-22 ... +266 °F)	-

Temperature derating

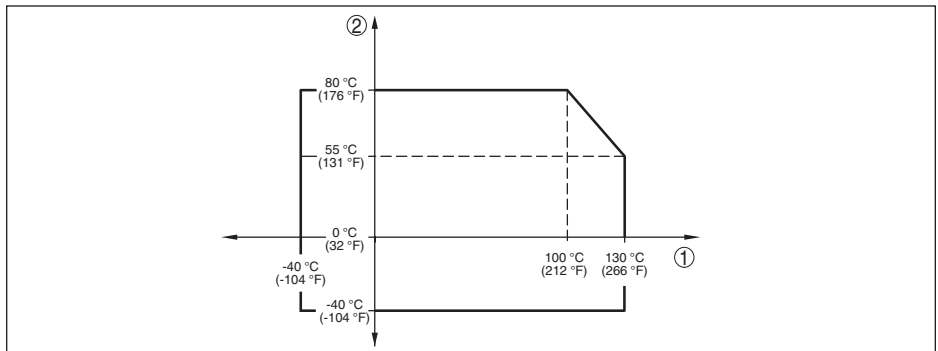

Fig. 41: Temperature derating CPT-2x, version up to +130 °C (+266 °F)

- 1 Process temperature
- 2 Ambient temperature

⁷⁾ With process fitting PVDF, process temperature max. 100 °C (212 °F).

⁸⁾ Measuring cell ø 28 mm

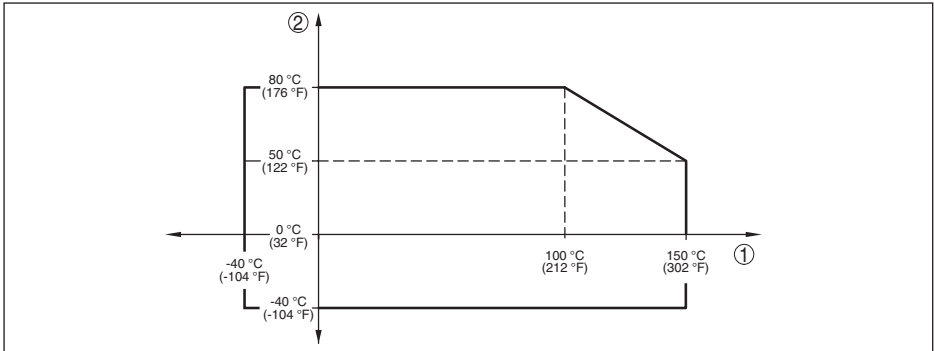

Fig. 42: Temperature derating CPT-2x, version up to +150 °C (+302 °F)

- 1 Process temperature
- 2 Ambient temperature

SIP process temperature (SIP = Sterilization in place)

Applies to instruments configurations suitable for vapour, i.e. material measuring cell seal EPDM or FFKM (Perlast G75S).

Vapour stratification up to 2 h +150 °C (+302 °F)

Process pressure

Permissible process pressure see specification "process pressure" on the type label

Mechanical stress⁹⁾

Vibration resistance 4 g at 5 ... 200 Hz according to EN 60068-2-6 (vibration with resonance)

Shock resistance 50 g, 2.3 ms according to EN 60068-2-27 (mechanical shock)¹⁰⁾

Electromechanical data - version IP 66/IP 67 and IP 66/IP 68 (0.2 bar)¹¹⁾

Options of the cable entry

- Cable entry M20 x 1.5; ½ NPT
- Cable gland M20 x 1.5, ½ NPT (cable ø see below table)
- Blind plug M20 x 1.5; ½ NPT
- Closing cap ½ NPT

Material cable gland/Seal insert	Cable diameter			
	5 ... 9 mm	6 ... 12 mm	7 ... 12 mm	10 ... 14 mm
PA/NBR	●	●	-	●
Brass, nickel-plated/NBR	●	●	-	-
Stainless steel/NBR	-	-	●	-

⁹⁾ Depending on the instrument version.

¹⁰⁾ 2 g with housing version stainless steel double chamber

¹¹⁾ IP 66/IP 68 (0.2 bar), only with absolute pressure.

Wire cross-section (spring-loaded terminals)

- Massive wire, stranded wire 0.2 ... 2.5 mm² (AWG 24 ... 14)
- Stranded wire with end sleeve 0.2 ... 1.5 mm² (AWG 24 ... 16)

Electromechanical data - version IP 66/IP 68 (1 bar)

Connection cable, mechanical data

- Configuration Wires, breather capillaries, strain relief, screen braiding, metal foil, mantle
- Standard length 5 m (16.4 ft)
- Min. bending radius 25 mm (0.984 in) with 25 °C (77 °F)
- Diameter approx. 8 mm (0.315 in)
- Colour - version PE Black
- Colour - version PUR Blue

Connection cable, electrical data

- Wire cross-section 0.5 mm² (AWG 20)
- Wire resistance R' 0.037 Ω/m (0.012 Ω/ft)

Electromechanical data - version IP 68 (25 bar)

Connection cable transmitter - external housing, mechanical data

- Configuration Wires, strain relief, breather capillaries, screen braiding, metal foil, mantle¹²⁾
- Standard length 5 m (16.40 ft)
- Max. length 180 m (590.5 ft)
- Min. bending radius at 25 °C/77 °F 25 mm (0.985 in)
- Diameter approx. 8 mm (0.315 in)
- Material PE, PUR
- Colour Black, blue

Connection cable transmitter - external housing, electrical data

- Wire cross-section 0.5 mm² (AWG 20)
- Wire resistance 0.037 Ω/m (0.012 Ω/ft)

Display and adjustment module

Display element Display with backlight

Measured value indication

- Number of digits 5

Adjustment elements

- 4 keys **[OK], [->], [+], [ESC]**

Protection rating

- unassembled IP 20
- Mounted in the housing without lid IP 40

¹²⁾ Breather capillaries not with Ex-d version.

Materials

- Housing	ABS
- Inspection window	Polyester foil
Functional safety	SIL non-reactive

Interface to the external display and adjustment unit

Data transmission	Digital (I ² C-Bus)
Connection cable	Four-wire

Sensor version	Configuration, connection cable	
	Max. cable length	Screened
4 ... 20 mA/HART 4 ... 20 mA/HART SIL	50 m	●
Profibus PA, Foundation Fieldbus	25 m	●

Interface to the slave sensor

Data transmission	Digital (I ² C-Bus)
Configuration, connection cable	4-wire, screened
Max. cable length	25 m

Integrated clock

Date format	Day.Month.Year
Time format	12 h/24 h
Time zone, factory setting	CET
Max. rate deviation	10.5 min/year

Additional output parameter - Electronics temperature

Range	-40 ... +85 °C (-40 ... +185 °F)
Resolution	< 0.1 K
Deviation	±3 K
Output of the temperature values	
- Indication	Via the display and adjustment module
- Analogue	Via the current output, the additional current output
- Digital	Via the digital output signal (depending on the electronics version)

Voltage supply

Operating voltage U _B	
- Non-Ex instrument	9.6 ... 35 V DC
- Ex-d instrument	9.6 ... 35 V DC
Operating voltage U _B with lighting switched on	
- Non-Ex instrument	16 ... 35 V DC
- Ex-d instrument	16 ... 35 V DC

Reverse voltage protection	Integrated
Permissible residual ripple - Non-Ex, Ex-ia instrument	
– for U_N 12 V DC ($9.6 \text{ V} < U_B < 14 \text{ V}$)	$\leq 0.7 V_{\text{eff}}$ (16 ... 400 Hz)
– for U_N 24 V DC ($18 \text{ V} < U_B < 35 \text{ V}$)	$\leq 1.0 V_{\text{eff}}$ (16 ... 400 Hz)
Load resistor	
– Calculation	$(U_B - U_{\text{min}})/0.022 \text{ A}$
– Example - Non-Ex instrument with $U_B = 24 \text{ V DC}$	$(24 \text{ V} - 9.6 \text{ V})/0.022 \text{ A} = 655 \Omega$

Potential connections and electrical separating measures in the instrument

Electronics	Not non-floating
Reference voltage ¹³⁾	500 V AC
Conductive connection	Between ground terminal and metallic process fitting

Electrical protective measures¹⁴⁾

Housing material	Version	Protection acc. to IEC 60529	Protection acc. to NEMA
Plastic	Single chamber	IP 66/IP 67	Type 4X
	Double chamber		
Aluminium	Single chamber	IP 66/IP 67 IP 66/IP 68 (0.2 bar) IP 68 (1 bar)	Type 4X Type 6P -
	Double chamber	IP 66/IP 67 IP 66/IP 68 (0.2 bar)	Type 4X Type 6P
Stainless steel (electro-polished)	Single chamber	IP 66/IP 67 IP 69K	Type 4X
Stainless steel (precision casting)	Single chamber	IP 66/IP 67 IP 66/IP 68 (0.2 bar) IP 68 (1 bar)	Type 4X Type 6P -
	Double chamber	IP 66/IP 67 IP 66/IP 68 (0.2 bar)	Type 4X Type 6P
Stainless steel	Transmitter, version with external housing	IP 68 (25 bar)	-

Connection of the feeding power supply unit Networks of overvoltage category III

Altitude above sea level

- by default up to 2000 m (6562 ft)
- with connected overvoltage protection up to 5000 m (16404 ft)

Pollution degree¹⁵⁾ 2

¹³⁾ Galvanic separation between electronics and metal housing parts
¹⁴⁾ Protection rating IP 66/IP 68 (0.2 bar) only in conjunction with absolute pressure.
¹⁵⁾ When used with fulfilled housing protection.

Protection rating (IEC/EN 61010-1) II

Approvals

Instruments with approvals can have deviating technical data (depending on the version). For such instruments, the corresponding approval documents must be noted.

11.2 Calculation of the total deviation

The total deviation of a pressure transmitter indicates the maximum measurement error to be expected in practice. It is also called maximum practical deviation or operational error.

According to DIN 16086, the total deviation F_{total} is the sum of the basic deviation F_{perf} and the long-term stability F_{stab} :

$$F_{\text{total}} = F_{\text{perf}} + F_{\text{stab}}$$

The basic deviation F_{perf} consists of the thermal change of the zero signal and the output span F_T as well as the deviation F_{Kl} :

$$F_{\text{perf}} = \sqrt{((F_T)^2 + (F_{Kl})^2)}$$

The thermal change of zero signal and output span F_T is specified in chapter "*Technical data*". The basic temperature error F_a is shown in a graphic. Depending on the measuring cell version and Turn down, this value must be multiplied with the additional factors FMZ and FTD:

$$F_T \times \text{FMZ} \times \text{FTD}$$

Also these values are specified in chapter "*Technical data*".

This applies for a digital signal output through HART, Profibus PA or Foundation Fieldbus.

With a 4 ... 20 mA output, the thermal change of the current output F_a must be added:

$$F_{\text{perf}} = \sqrt{((F_T)^2 + (F_{Kl})^2 + (F_a)^2)}$$

To provide a better overview, the formula symbols are listed together below:

- F_{total} : Total deviation
- F_{perf} : Basic deviation
- F_{stab} : Long-term stability
- F_T : Thermal change of zero signal and output span (temperature error)
- F_{Kl} : Deviation
- F_a : Thermal change of the current output
- FMZ: Additional factor measuring cell version
- FTD: Additional factor Turn down

11.3 Calculation of the total deviation - Practical example

Data

Pressure measurement in the pipeline 4 bar (400 KPa)

Product temperature up to 50 °C

CPT-2x with measuring range 10 bar, deviation < 0.2 %, process fitting G1½ (measuring cell ø 28 mm)

1. Calculation of the Turn down

$$\text{TD} = 10 \text{ bar} / 4 \text{ bar}, \text{TD} = 2.5 : 1$$

2. Determination temperature error F_T

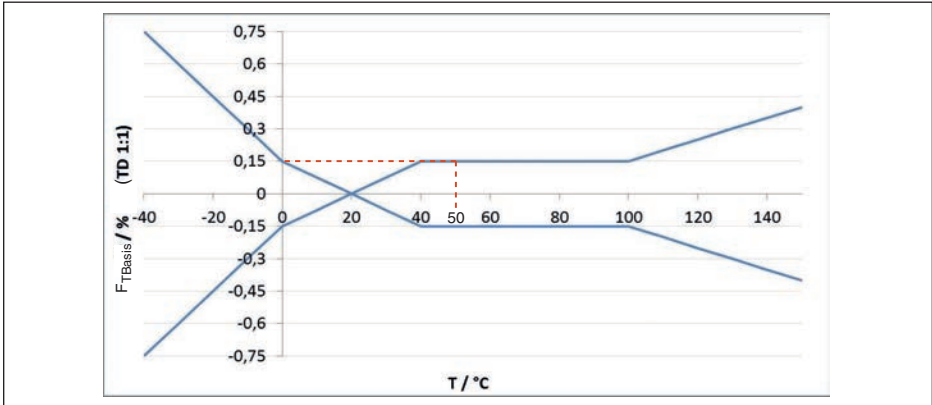

Fig. 43: Determination of the basic temperature error for the above example: $F_{TBasis} = 0.15\%$

Measuring cell version	Measuring cell standard, depending on the accuracy class		
	0.05 %, 0.1 %	0.2 % (0.1 bar _{abs})	0.2 %
Factor FMZ	1	2	3

Tab. 24: Determination of the additional factor measuring cell for above example: $F_{MZ} = 3$

Turn Down	TD 1 : 1	TD 2.5 : 1	TD 5 : 1	TD 10 : 1	TD 20 : 1
Factor FTD	1	1.75	3	5.5	10.5

Tab. 25: Determination of the additional factor "turn down" for the above example: $F_{TD} = 1.75$

$$F_T = F_{TBasis} \times F_{MZ} \times F_{TD}$$

$$F_T = 0.15\% \times 3 \times 1.75$$

$$F_T = 0.79\%$$

3. Determination of deviation and long-term stability

The required values for deviation F_{KI} and long-term stability F_{stab} are available in the technical data:

Accuracy class	Non-linearity, hysteresis and non-repeatability	
	TD \leq 5 : 1	TD $>$ 5 : 1
0.05 %	$< 0.05\%$	$< 0.01\% \times TD$
0.1 %	$< 0.1\%$	$< 0.02\% \times TD$
0.2 %	$< 0.2\%$	$< 0.04\% \times TD$

Tab. 26: Determination of the deviation from table: $F_{KI} = 0.2\%$

Time period	Measuring cell ø 28 mm		Measuring cell ø 17.5 mm	
	All measuring ranges	Measuring range 0 ... +0.025 bar (0 ... +2.5 kPa)	All process fittings	Process fitting G½ (ISO 228-1)
One year	< 0.05 % x TD	< 0.1 % x TD	< 0.1 % x TD	< 0.25 % x TD
Five years	< 0.1 % x TD	< 0.2 % x TD	< 0.2 % x TD	< 0.5 % x TD
Ten years	< 0.2 % x TD	< 0.4 % x TD	< 0.4 % x TD	< 1 % x TD

Tab. 27: Determination of the long-term stability from the table, consideration for one year: $F_{stab} = 0.05 \% \times TD$

4. Calculation of the total deviation - HART signal

- 1. step: Basic deviation F_{perf}

$$F_{perf} = \sqrt{((F_T)^2 + (F_{Kl})^2)}$$

$$F_T = 0.79 \%$$

$$F_{Kl} = 0.2 \%$$

$$F_{perf} = \sqrt{(0.79 \%)^2 + (0.2 \%)^2}$$

$$F_{perf} = 0.81 \%$$

- 2. step: Total deviation F_{total}

$$F_{total} = F_{perf} + F_{stab}$$

$$F_{perf} = 0.81 \%$$
 (result of step 1)

$$F_{stab} = (0.05 \% \times TD)$$

$$F_{stab} = (0.05 \% \times 2.5)$$

$$F_{stab} = 0.125 \%$$

$$F_{total} = 0.81 \% + 0.13 \% = 0.94 \%$$

5. Calculation of the total deviation - 4 ... 20 mA signal

- 1. step: Basic deviation F_{perf}

$$F_{perf} = \sqrt{((F_T)^2 + (F_{Kl})^2 + (F_a)^2)}$$

$$F_T = 0.79 \%$$

$$F_{Kl} = 0.2 \%$$

$$F_a = 0.15 \%$$

$$F_{perf} = \sqrt{(0.79 \%)^2 + (0.2 \%)^2 + (0.15 \%)^2}$$

$$F_{perf} = 0.83 \%$$

- 2. step: Total deviation F_{total}

$$F_{total} = F_{perf} + F_{stab}$$

$$F_{stab} = (0.05 \% \times TD)$$

$$F_{stab} = (0.05 \% \times 2.5)$$

$$F_{stab} = 0.13 \%$$

$$F_{total} = 0.83 \% + 0.13 \% = 0.96 \%$$

The example shows that the measurement error in practice can be considerably higher than the basic deviation. Reasons are temperature influence and Turn down.

11.4 Dimensions

Plastic housing

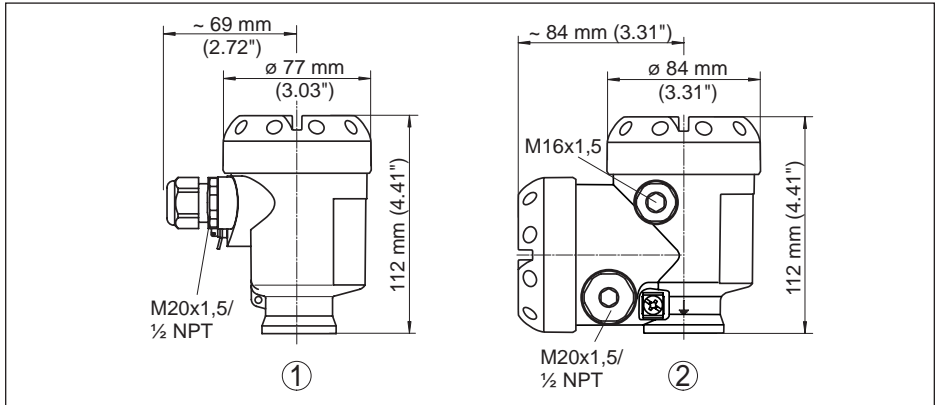

Fig. 44: Housing versions in protection IP 66/IP 67 (with integrated display and adjustment module the housing is 9 mm/0.35 in higher)

- 1 Plastic single chamber
- 2 Plastic double chamber

Aluminium housing

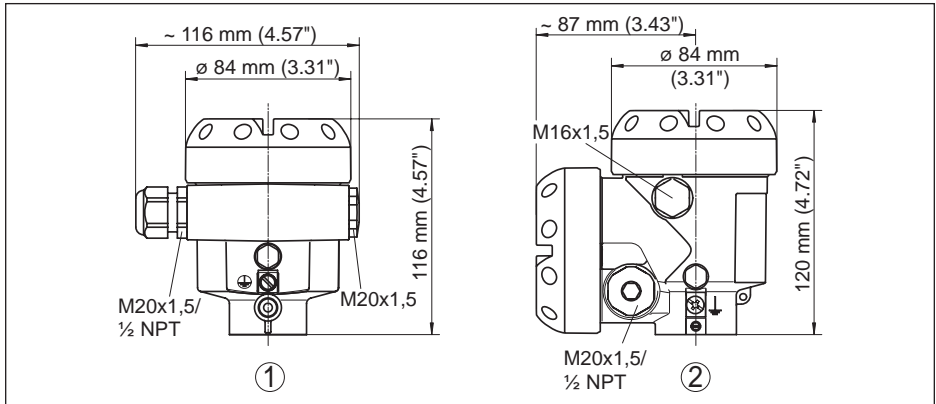

Fig. 45: Housing versions in protection IP 66/IP 67 (with integrated display and adjustment module the housing is 9 mm/0.35 in higher)

- 1 Aluminium - single chamber
- 2 Aluminium - double chamber

Aluminium housing with protection rating IP 66/IP 68 (1 bar)

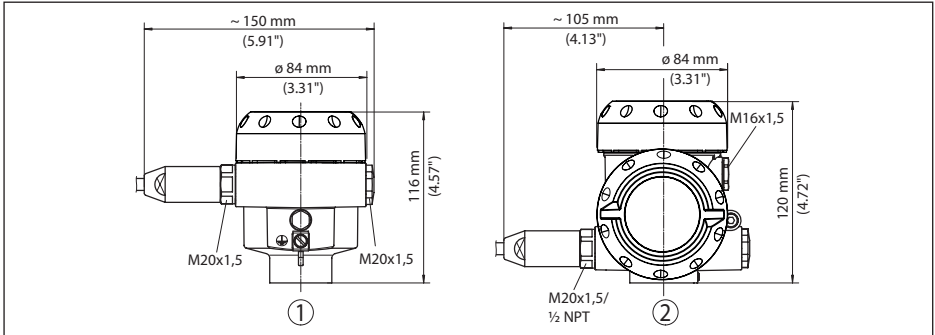

Fig. 46: Housing version with protection rating IP 66/IP 68 (1 bar), (with integrated display and adjustment module the housing is 9 mm/0.35 in higher)

- 1 Aluminium - single chamber
- 2 Aluminium - double chamber

Stainless steel housing

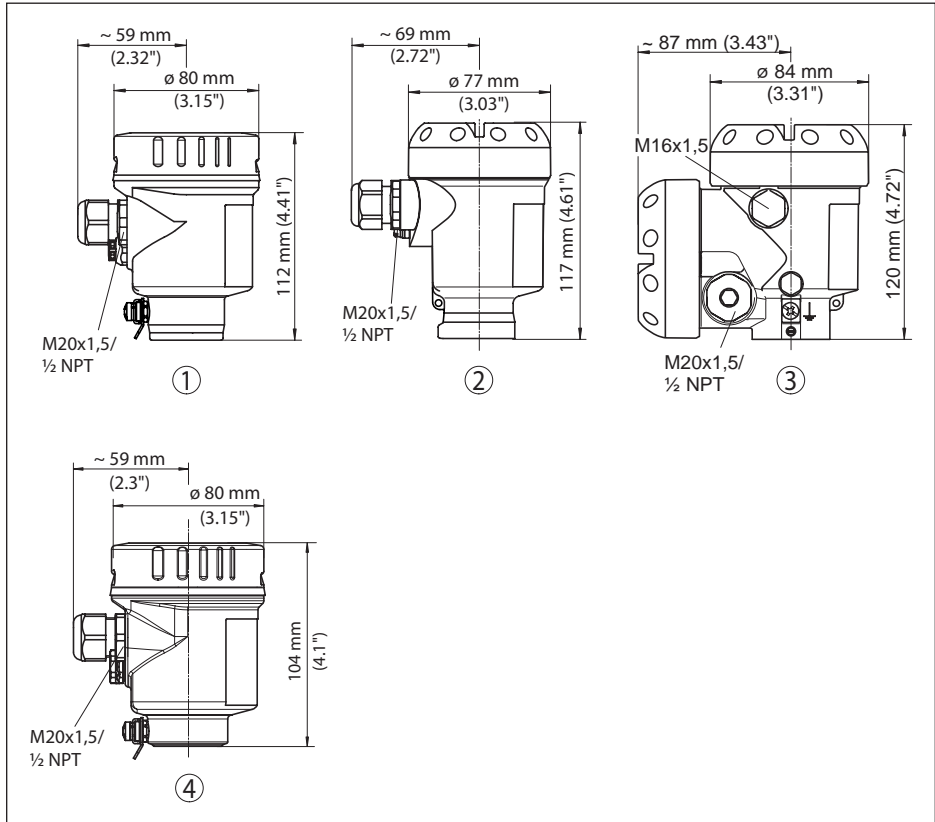

Fig. 47: Housing versions in protection IP 66/IP 67 (with integrated display and adjustment module the housing is 9 mm/0.35 in higher)

- 1 Stainless steel single chamber (electropolished)
- 2 Stainless steel single chamber (precision casting)
- 3 Stainless steel double chamber housing (precision casting)

Stainless steel housing with protection rating IP 66/IP 68 (1 bar)

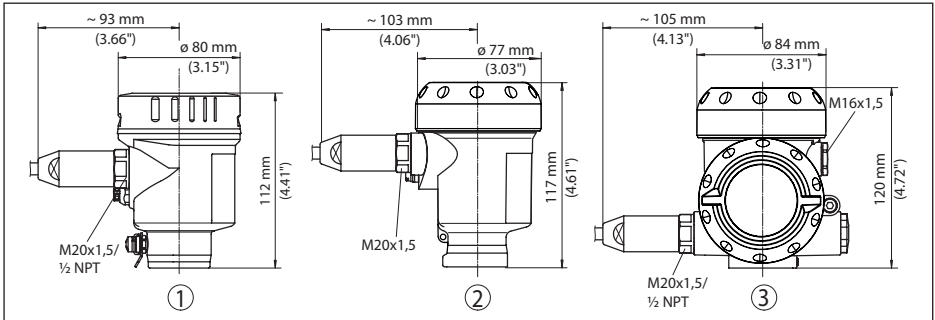

Fig. 48: Housing version with protection rating IP 66/IP 68 (1 bar), (with integrated display and adjustment module the housing is 9 mm/0.35 in higher)

- 1 Stainless steel single chamber (electropolished)
- 2 Stainless steel single chamber (precision casting)
- 3 Stainless steel double chamber housing (precision casting)

Stainless steel housing with protection rating IP 69K

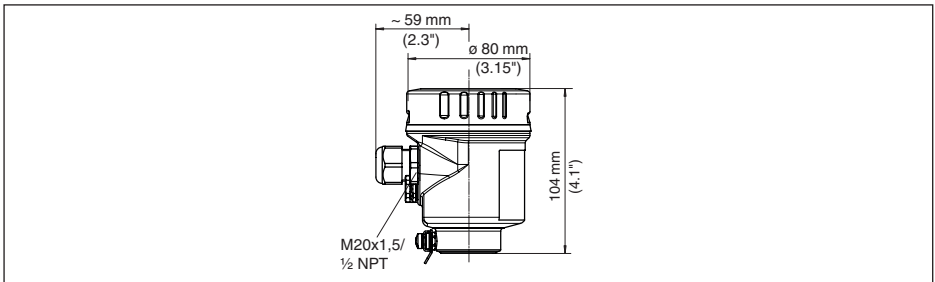

Fig. 49: Housing version with protection rating IP 69K (with integrated display and adjustment module the housing is 9 mm/0.35 in higher)

- 1 Stainless steel single chamber (electropolished)

External housing with IP 68 (25 bar) version

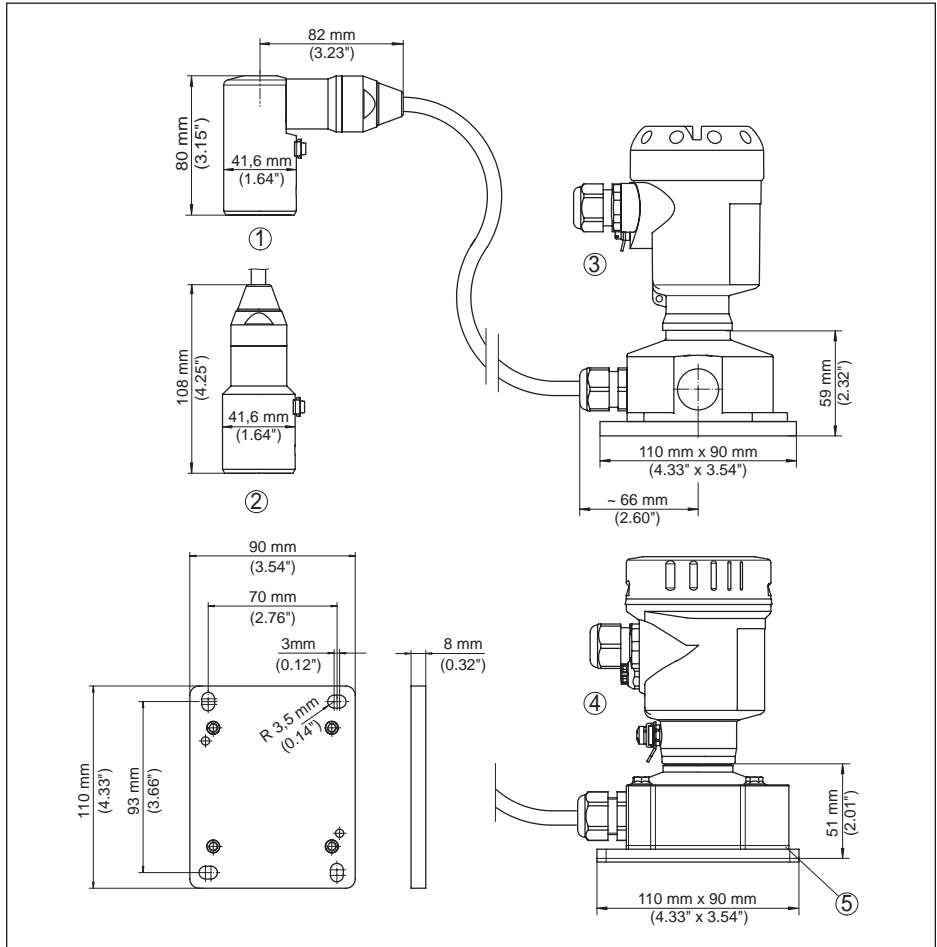

Fig. 50: IP 68 version with external housing

- 1 Lateral cable outlet
- 2 Axial cable outlet
- 3 Plastic housing
- 4 Stainless steel housing, electropolished

CPT-2x, threaded fitting not front-flush

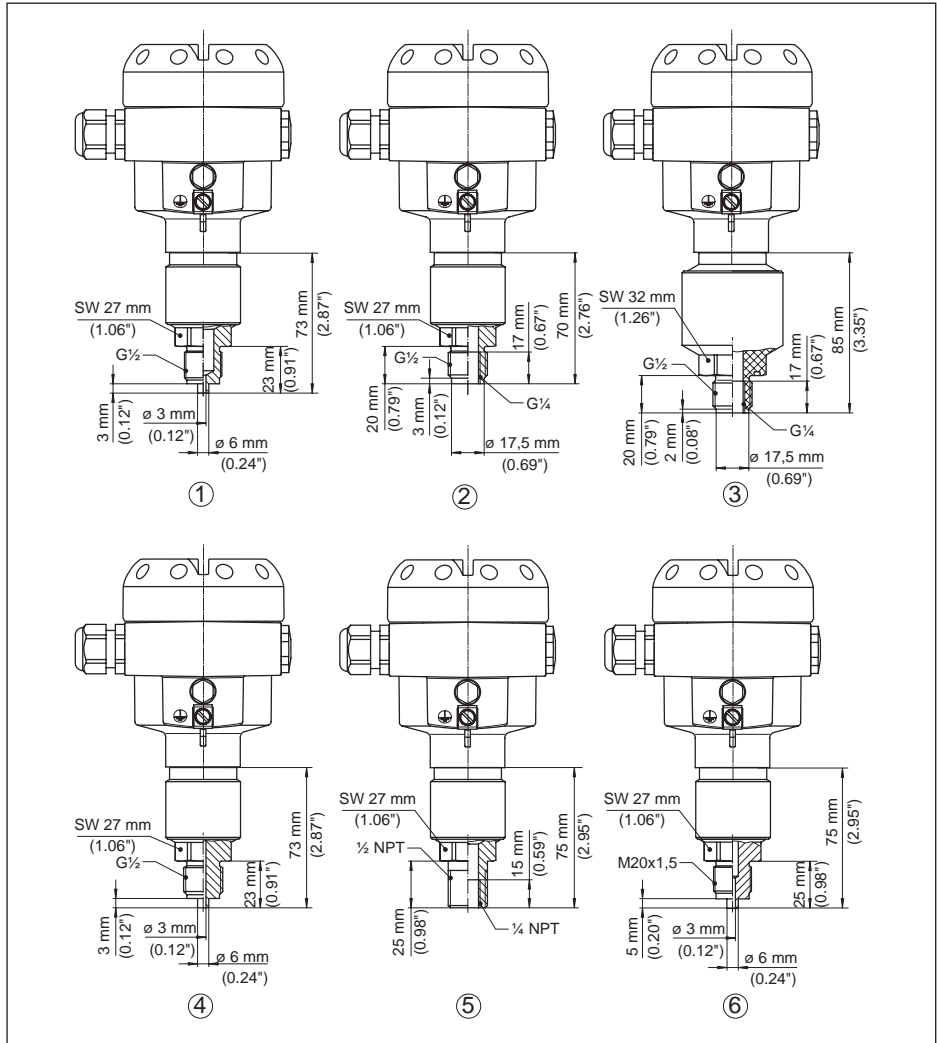

Fig. 51: CPT-2x, threaded fitting not front-flush

- 1 $G\frac{1}{2}$ manometer connection (EN 837)
- 2 $G\frac{1}{2}$ A inside $G\frac{1}{4}$ (ISO 228-1)
- 3 $G\frac{1}{2}$ A inside $G\frac{1}{4}$ A PVDF (ISO 228-1)
- 4 $G\frac{1}{2}$ manometer connection (EN 837) volume-reduced
- 5 $\frac{1}{2}$ NPT inside $\frac{1}{4}$ NPT
- 6 M20 x 1.5 manometer connection (EN 837)

Notes:

For the version with "Second Line of Defense", the measure of length increases by 17 mm (0.67 in).

CPT-2x, threaded fitting front-flush

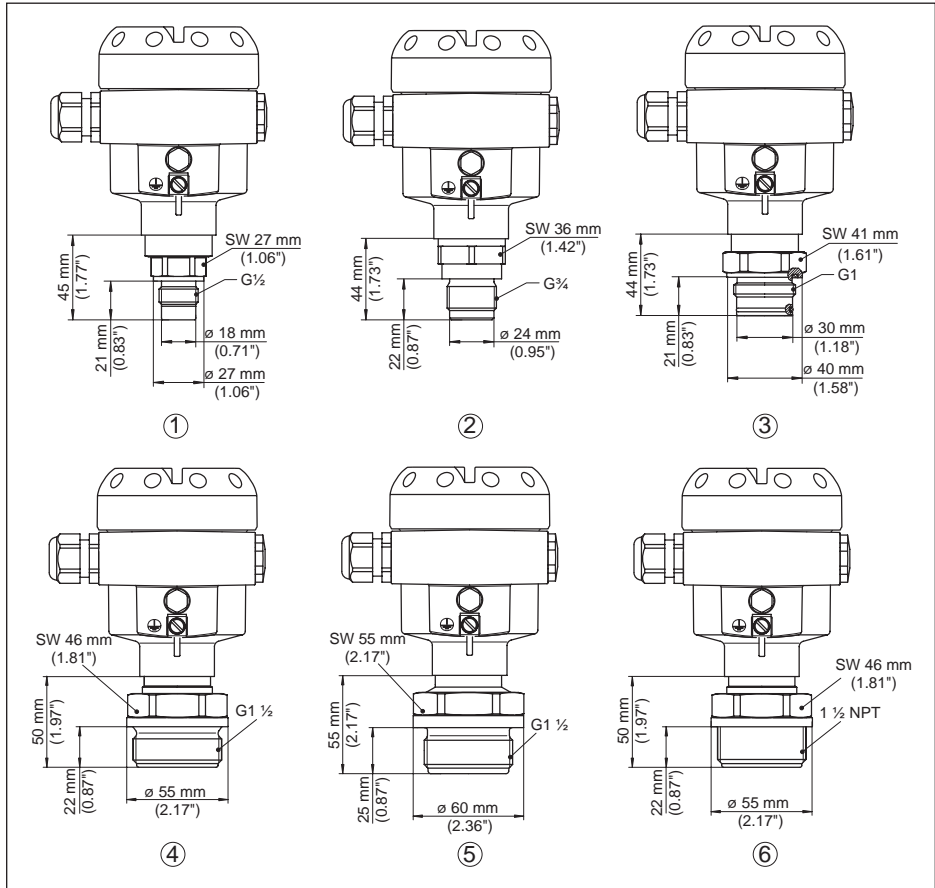

Fig. 52: CPT-2x, threaded fitting front-flush

- 1 G $\frac{1}{2}$ (ISO 228-1)
- 2 G $\frac{3}{4}$ (DIN 3852-E)
- 3 G1 A (ISO 228-1)
- 4 G1 $\frac{1}{2}$ (DIN 3852-A)
- 5 G1 $\frac{1}{2}$ A PVDF (DIN 3852-A-B)
- 6 1 $\frac{1}{2}$ NPT (ASME B1.20.1)

For the version with temperature range up to 150 °C/302 °F, the measure of length increases by 28 mm (1.1 in).

For the version with "Second Line of Defense", the measure of length increases by 17 mm (0.67 in).

CPT-2x, hygienic fitting

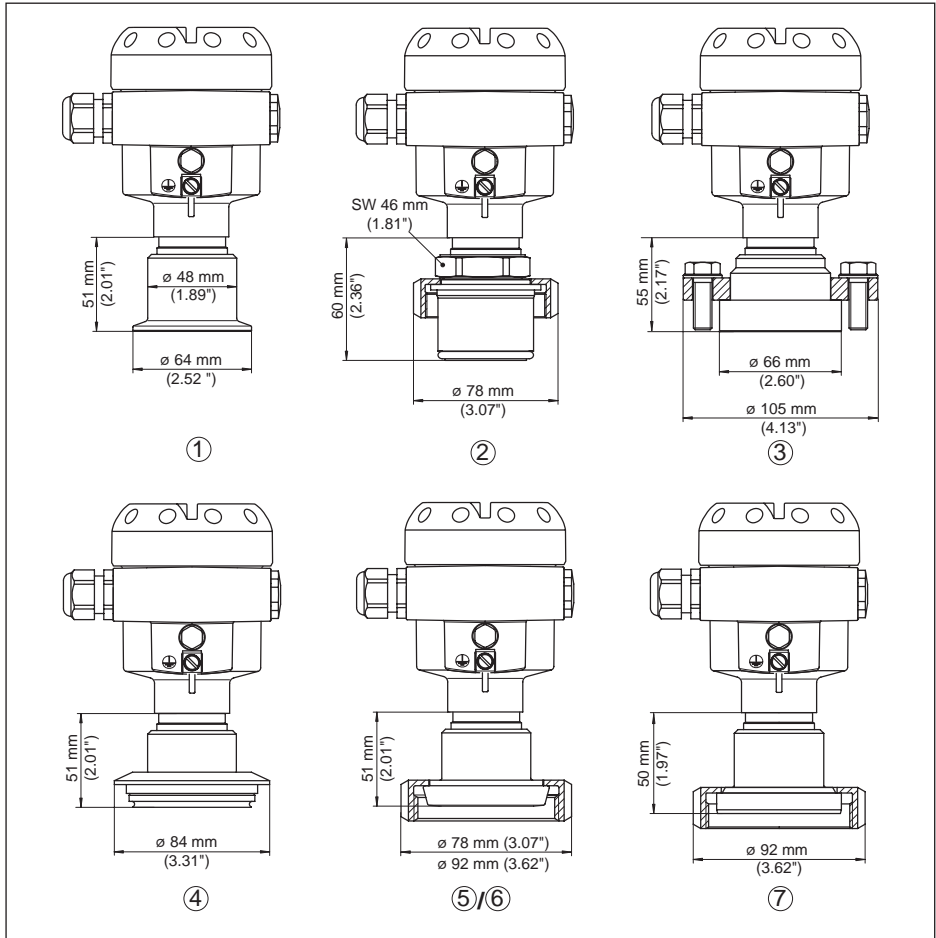

Fig. 53: CPT-2x, hygienic fitting

- 1 Clamp 2"
- 2 Hygienic connection with compression nut F40
- 3 DRD
- 4 Tuchenhagen Varivent DN 32
- 5 Slotted nut DN 40 according to DIN 11851
- 6 Slotted nut DN 50 according to DIN 11851
- 7 Slotted nut DN 50 according to DIN 11864-1

For the version with temperature range up to 150 °C/302 °F, the measure of length increases by 28 mm (1.1 in).

For the version with "Second Line of Defense", the measure of length increases by 17 mm (0.67 in).

CPT-2x, flange connection

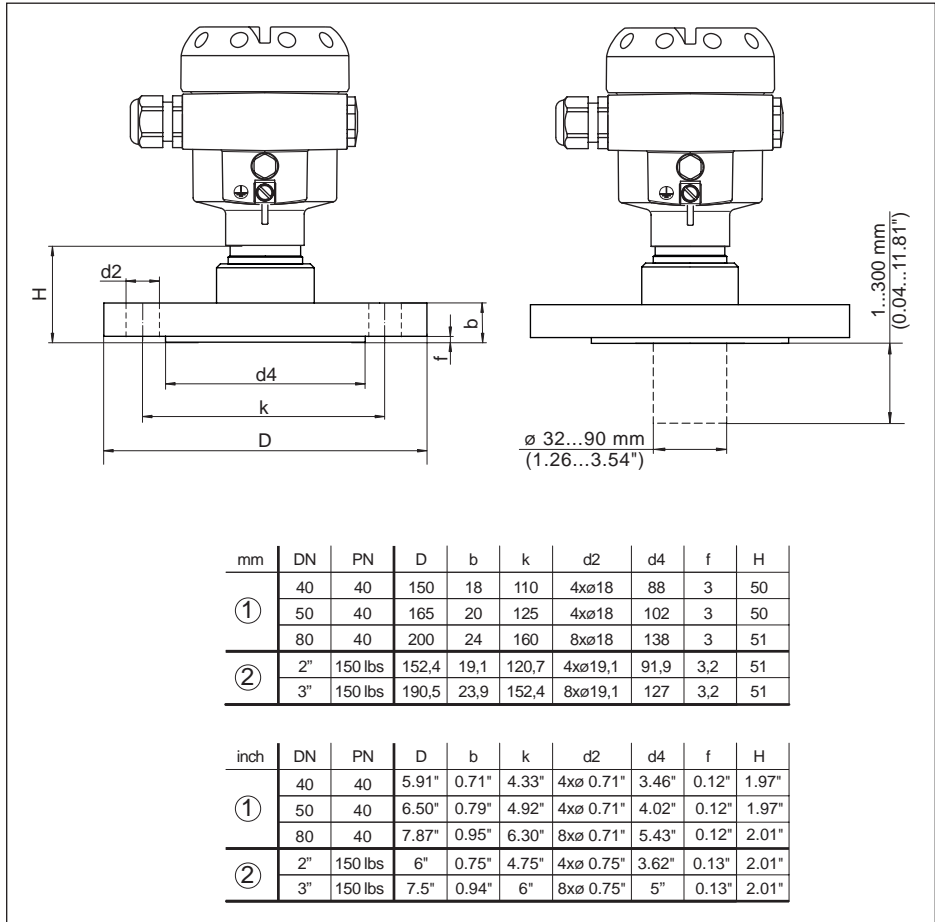

Fig. 54: CPT-2x, flange connection

- 1 Flange connection according to DIN 2501
- 2 Flange connection according to ASME B16.5

For the version with temperature range up to 150 °C/302 °F, the measure of length increases by 28 mm (1.1 in).

For the version with "Second Line of Defense", the measure of length increases by 17 mm (0.67 in).

CPT-2x, extension fitting

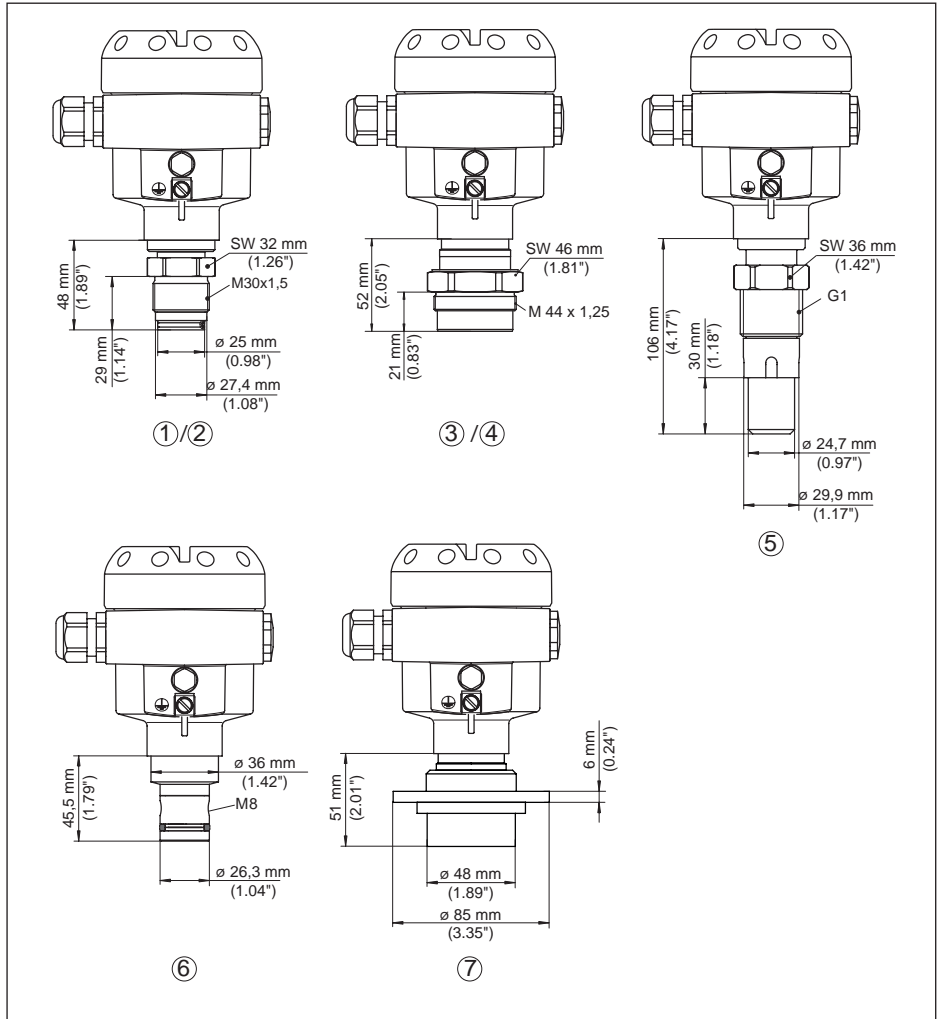

Fig. 55: CPT-2x, extension fitting

- 1 M30 x 1.5 DIN 13; completely front-flush
- 2 M30 x 1.5 DIN 13; for headbox
- 3 M44 x 1.25 DIN 13; pressure screw: Aluminium
- 4 M44 x 1.25 DIN 13; pressure screw: 316L
- 5 G1, ISO 228-1 suitable for PASVE
- 6 PMC 1" front-flush PN 6
- 7 DN 48 with tension flange

For the version with temperature range up to 150 °C/302 °F, the measure of length increases by 28 mm (1.1 in).

For the version with "Second Line of Defense", the measure of length increases by 17 mm (0.67 in).

CPT-2x, connection acc. to IEC 61518

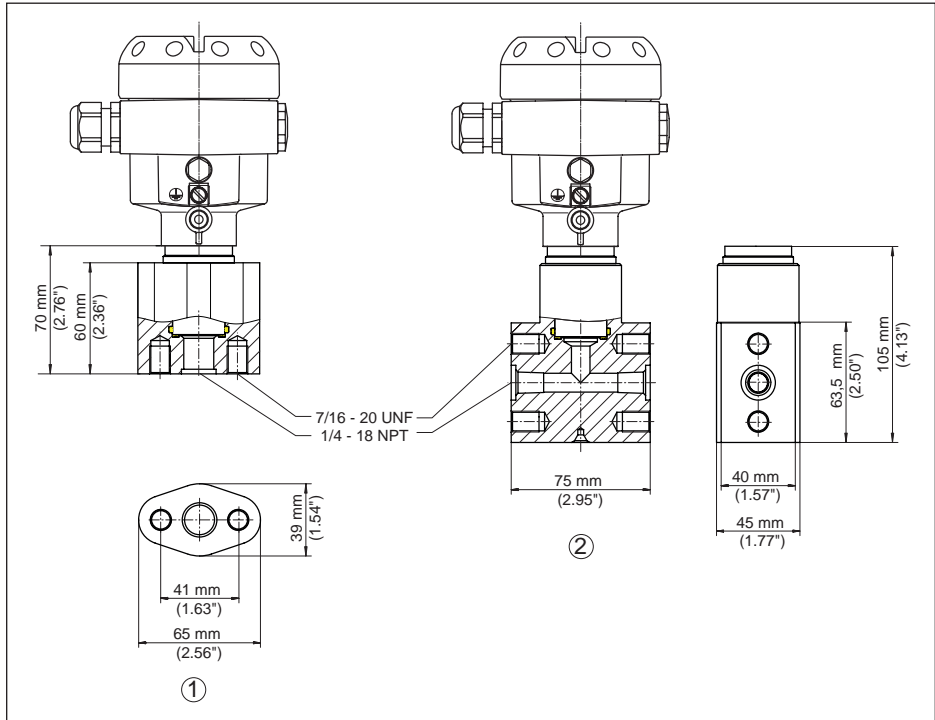

Fig. 56: CPT-2x, connection acc. to IEC 61518

- 1 Oval flange adapter
- 2 Top flange

For the version with temperature range up to 150 °C/302 °F, the measure of length increases by 28 mm (1.1 in).

For the version with "Second Line of Defense", the measure of length increases by 17 mm (0.67 in).

11.5 Trademark

All the brands as well as trade and company names used are property of their lawful proprietor/originator.

INDEX

A

- Adjust Date/Time 46
- Adjustment 37, 41, 42
 - Process pressure 40, 41
 - System 36
 - Unit 38
- Adjust the current output 49

C

- Change the language 44
- Check output signal 59
- Copy sensor settings 48
- Current output 42, 43

D

- Damping 42
- Default values 47
- Display lighting 45

E

- Electrical connection 23, 24
- Error codes 57, 58, 59
- Event memory 55

F

- Fault rectification 59

G

- Grounding 23

H

- HART
 - Mode 49

L

- Linearisation 42

M

- Maintenance 54
- Measured value memory 55
- Measurement setup 19, 20, 21

N

- NAMUR NE 107 56
 - Function check 58

P

- Parameterization example 39
- Peak value indicator
 - Pressure 45

- Temperature 46
- PIN 32
- Position correction 39
- Pressure compensation 19
 - Ex d 18
 - Standard 18
- Process pressure measurement 20

R

- Reset 46

S

- Safety Integrity Level (SIL)
 - Lock adjustment 43
 - Operating sequence 37
- Seal concept 11
- Service access 50
- Set display parameters 45
- Simulation 46

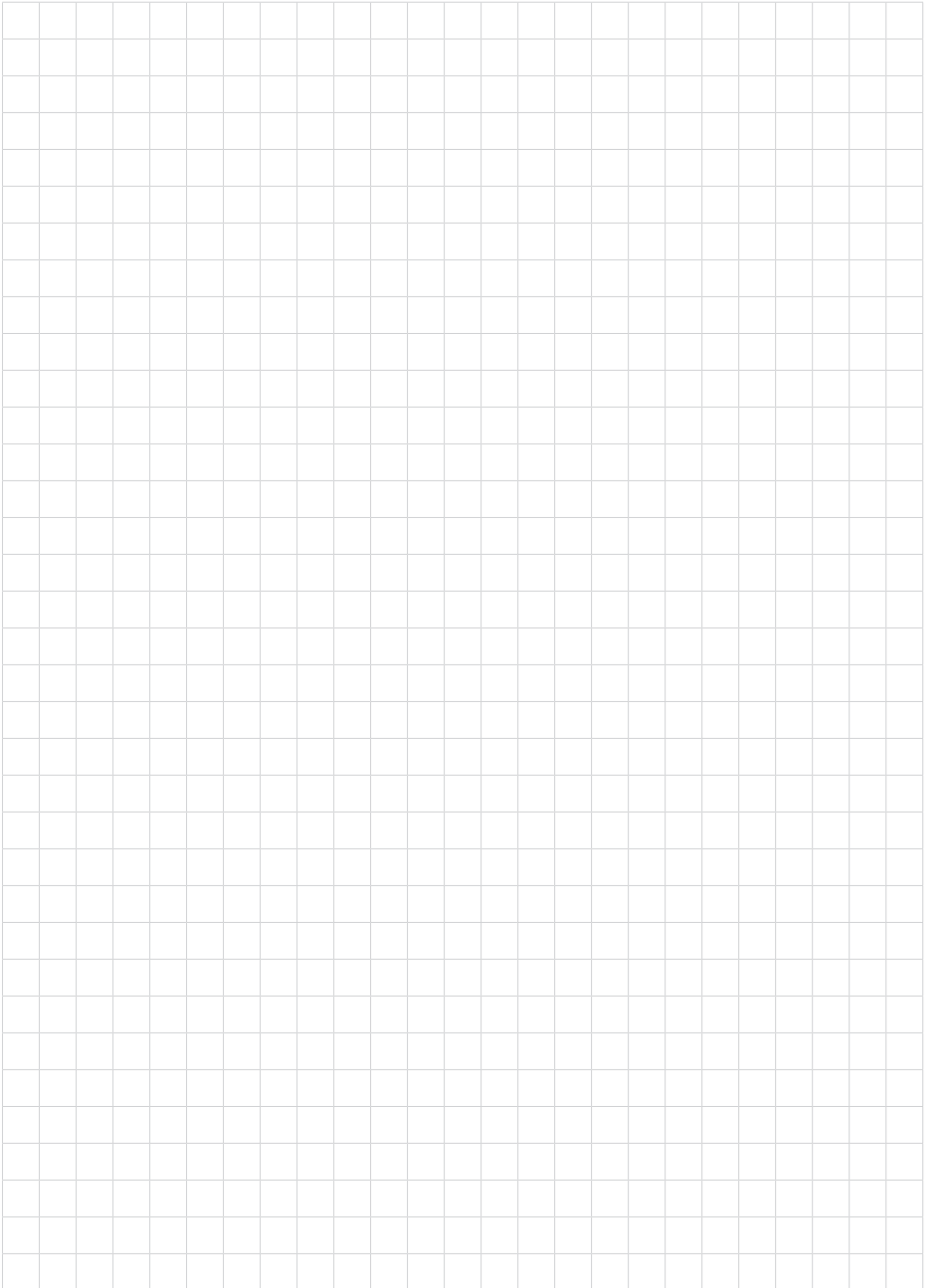

Printing date:

All statements concerning scope of delivery, application, practical use and operating conditions of the sensors and processing systems correspond to the information available at the time of printing.



WIKAI Alexander Wiegand SE & Co. KG
Alexander-Wiegand-Straße 30
63911 Klingenberg
Germany
Phone (+49) 9372/132-0
Fax (+49) 9372 132-406
E-mail: info@wika.de
www.wika.de

52750-EN-190320