

PyroUSB 2.2 Series Operators Guide



PyroUSB 2.2 Series non-contact infrared sensors measure temperatures from 45°C to 2000°C and provide a linear 0 to 20 or 4 to 20 mA output. The signal is compatible with almost any indicator, controller, recorder, data logger etc., without the need for special interfacing or signal conditioning. They are especially suited to low-emissivity targets such as steel rollers and other metal surfaces, even at low temperatures.

SPECIFICATION

GENERAL

Temperature Range	LT: 45°C* to 300°C (PU151LT2.2 only) PT: 100 to 400°C (PU151PT2.2 only) MT: 250°C to 1000°C HT: 450°C to 2000°C
Output	4 to 20 mA, 0 to 20 mA (linear with temperature, adjustable via software)
Accuracy*	±1% of reading or ±2°C whichever is greater
Repeatability*	±0.5% of reading or ±0.5°C whichever is greater
Emissivity	0.1 to 1.0, adjustable via software
Response Time	≥ 240 ms (90% response)
Field-of-View	15:1 (PU151LT or PT) 25:1 (PU251MT or HT) 75:1 (PU751MT or HT) ø7.5mm @ 500mm (PUCFMT or HT)
Spectral Response	2.0 to 2.4 µm
Supply Voltage	24 V DC (26 V DC max.)
Sensor Voltage	11 V DC min.
Maximum Loop Impedance	900 ohms @ 24 V DC

MECHANICAL

Construction	Stainless Steel
Dimensions	25 mm diameter x 106.5 mm
Output Cable Length	1 m (longer cable available to order)
USB Cable Length	1 m
Weight with Output Cable	175 g

ENVIRONMENTAL

Environmental Rating	IP65
Ambient Temperature Range	0°C to 70°C
Relative Humidity	95% maximum non-condensing
Electromagnetic Compatibility	EN61326-1:2006 Industrial (analogue output only) EN61326-1:2006 Basic (USB)

* Object temperature > T_{min} (see graph of Minimum Measurable Temperature on page 8)

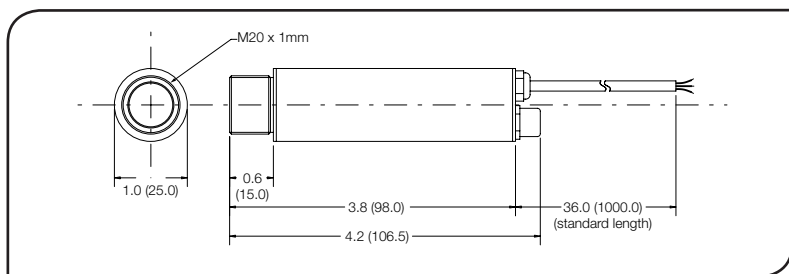

ACCESSORIES

A range of accessories to suit different applications and industrial environments is available. These may be ordered at any time and added on-site. The accessories consist of the following parts .

- Fixed mounting bracket
- Adjustable mounting bracket
- Air purge collar
- Laser sighting tool

OPTIONS

The following options are available. Options are factory installed and must be ordered with the PyroUSB 2.2 sensor.

- Air/water cooled housing
- Certificate of calibration
- Longer cable (30 m max.)

OPTICAL CHART

The optical chart below indicates the nominal target spot diameter at any given distance from the sensing head and assumes 90% energy.

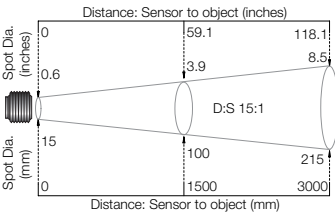

PyroUSB 2.2-151

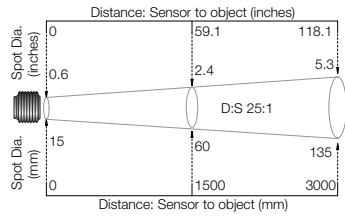

PyroUSB 2.2-251

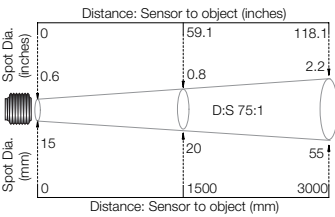

PyroUSB 2.2-751

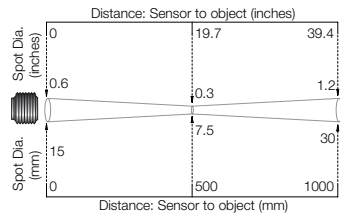

PyroUSB 2.2-CF

INSTALLATION

The installation process consists of the following stages:

- Preparation
- Mechanical installation
- Electrical installation

Please read the following sections thoroughly before proceeding with the installation.

PREPARATION

Ensure that the sensor is positioned so that it is focused on the target only.

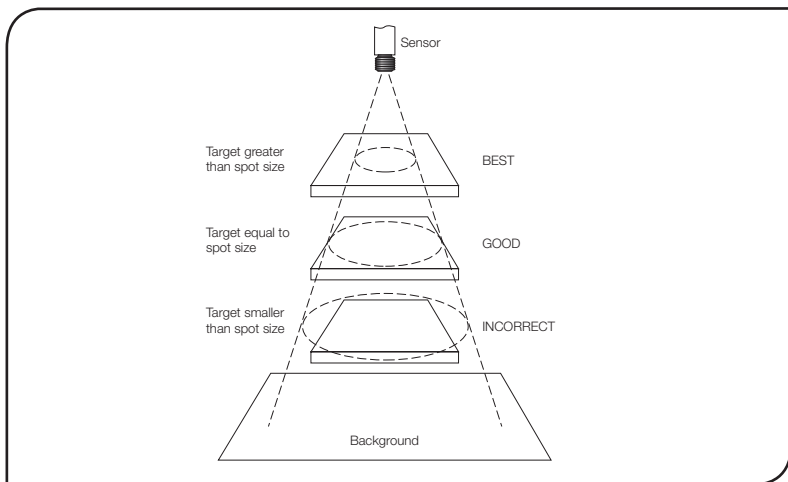

DISTANCE AND SPOT SIZE

The size of the area (spot size) to be measured determines the distance between the sensor and the target. The spot size must not be larger than the target. The sensor should be mounted so that the measured spot size is smaller than the target.

REFLECTIONS

The sensor must be installed in a location where energy from lamps, heaters and sunlight cannot be reflected from the target into the lens. The use of shields may help in this respect. For further information and assistance contact Calex.

AMBIENT TEMPERATURE

The sensor is designed to operate in ambient temperatures from 0°C to 70°C. For ambient temperatures above 70°C, an air/water-cooled housing will be required.

Avoid thermal shock. Allow 20 minutes for the unit to adjust to large changes in ambient temperature.

ATMOSPHERIC QUALITY

Smoke, fumes or dust can contaminate the lens and cause errors in temperature measurement. In these types of environment the air purge collar should be used to help keep the lens clean.

ELECTRICAL INTERFERENCE

To minimise electromagnetic interference or 'noise', the sensor should be mounted away from motors, generators and such like.

WIRING

Check the distance between the sensor and the indicating/controlling device. If necessary, the PyroUSB 2.2 sensor can be ordered with a longer output cable attached.

MECHANICAL INSTALLATION

All sensors come with a 1 m cable and a mounting nut. The sensor can be mounted on brackets or cut outs of your own design, or you can use the fixed and adjustable mounting bracket accessories which are shown below.

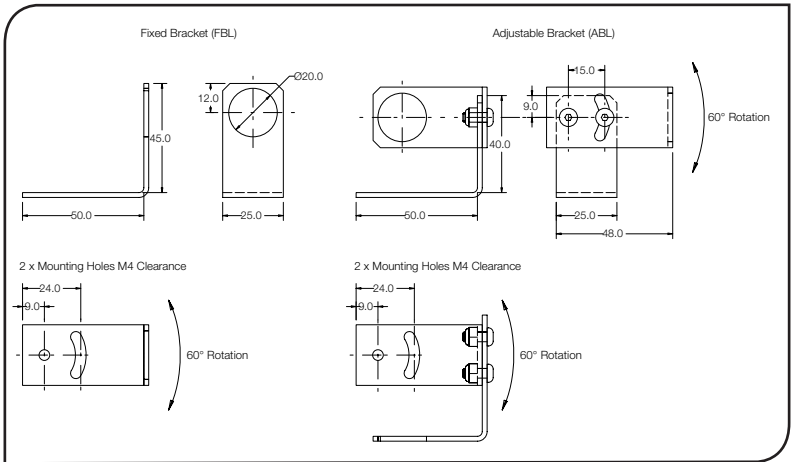

AIR/WATER COOLED HOUSING

The air/water cooled housing shown below allows the sensor to withstand high ambient temperatures. It is equipped with two 1/8" BSP fittings. Water temperature should be 10°C to 27°C for efficient cooling. Chilled water below 10°C is not recommended. To avoid condensation, the air purge collar, supplied with the cooled housing, should be used.

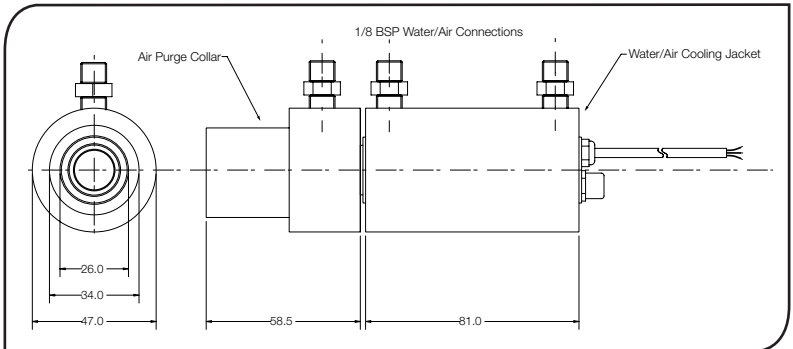

AIR PURGE COLLAR

The air purge collar below is used to keep dust, fumes, moisture, and other contaminants away from the lens. It must be screwed in fully. Air flows into the 1/8" BSP fitting and out of the front aperture. Air flow should be no more than 5 to 15 litres/min.

Clean or 'instrument' air is recommended.

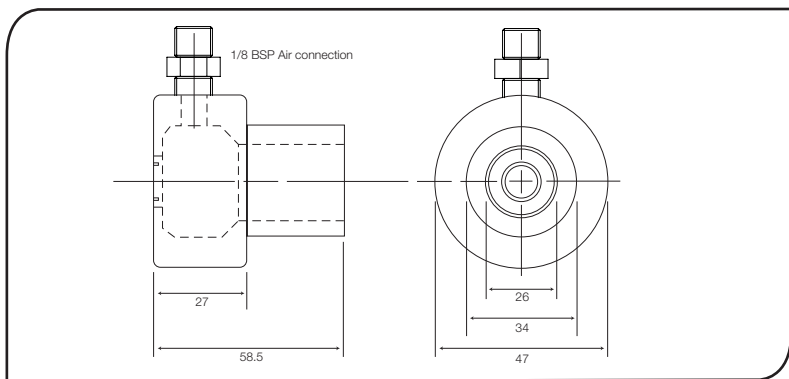

ELECTRICAL INSTALLATION

The sensor to electronics cable is a 1 m PTFE cable. One end is attached, at the factory, to the sensor head. The other end has two pairs of wires and a shield (ground) wire.

WIRING

The PyroUSB 2.2 sensor can be used in three different ways as shown below. To use the analogue output, connect the PyroUSB 2.2 sensor to the controller/indicator with the 24 V DC power supply using the following table and connection diagram as a guide. The maximum loop impedance is 900 ohms. **Note: The PyroUSB 2.2 sensor must be grounded at only one point, either the cable shield or the sensor housing.**

Wire No.	Wire Colour	Function	Tag
1	Red	Power supply +	PWR +
2	Blue	Power supply -	PWR -
3	Yellow	Signal +	OP +
4	Green	Signal -	OP -
5	Bare	Shield ground	

Alternatively, to use the USB output, connect the PyroUSB 2.2 sensor to a PC using the cable provided. No external power supply is required when using the USB output. The PyroUSB 2.2 sensor can also be used with both the analogue output and USB connected, provided that the negative terminal of the 24 V DC power supply being used is not grounded. **Note: The CalexSoft software must be installed before connecting the sensor to a PC.**

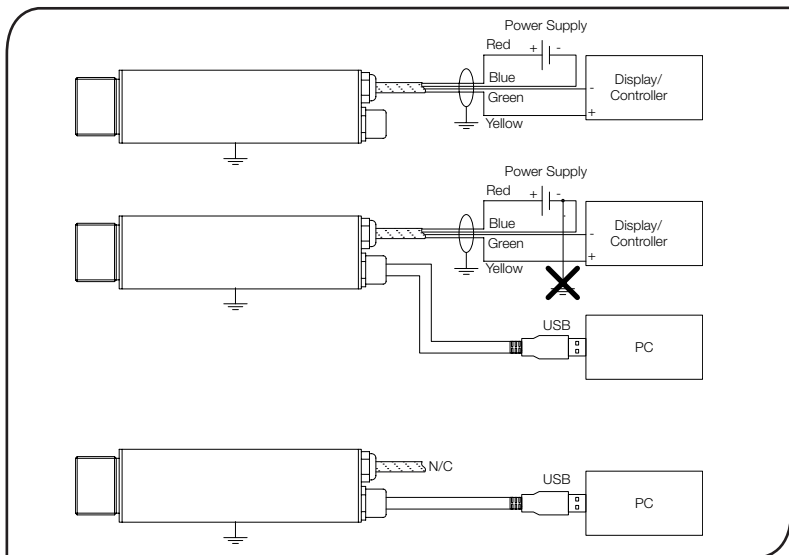

CALEXSOFT SOFTWARE SYSTEM REQUIREMENTS

- CalexSoft software is designed to run under Windows. Suitable versions are Windows 2000, Windows XP, Windows Vista and Windows 7.
- The recommended minimum computer specification is:
Intel Pentium processor
VGA display with 640x480 resolution
USB 2.0 port

INSTALLATION

1. Insert the disk provided
2. Installer should run automatically (if not, select the appropriate drive and double click on Setup.exe)
3. Follow the on-screen instructions

NOTE Do not connect the PyroUSB 2.2 Sensor to the PC before the software is installed

CONNECTING THE PYROUSB 2.2 SENSOR TO A PC

1. Connect the circular connector on the USB cable provided to the PyroUSB 2.2 sensor
2. Connect the USB A connector on the USB cable provided to an available USB 2.0 port
3. Double click on the CalexSoft desktop icon

CONFIGURATION

- Setting Temperature Units
Temperature units can be set on the main temperature panel by pressing °C or °F.

- Setting Output Processing

The temperature range for the analogue output, the averaging period and the peak/valley hold processing can be set by using the main program menu to select: [Setup] → [Output Processing]

The temperatures corresponding to the lower and upper limits of the analogue output can then be set as follows:

Model	Lower Limit	Upper Limit	Minimum Span	Maximum Span
LT	45°C	300°C	100°C	255°C
PT	100°C	400°C	100°C	300°C
MT	250°C	1000°C	100°C	750°C
HT	450°C	2000°C	100°C	1550°C

The output type can be selected as either 0 mA to 20 mA or 4 mA to 20 mA.

To minimise the the effects of temperature fluctuations, noise etc on the output signal, the averaging period can be set between 0 and 60 seconds.

If required, Hold Processing can be applied by setting hold mode to Peak Hold or Valley Hold and setting a hold period between 0 and 1200 seconds.

- Setting Target Emissivity

To set an emissivity value for the PyroUSB 2.2 sensor, use the main program menu to select:

[Setup] → [Emissivity]

Emissivity can then be set to a value between 0.1 and 1.0, or selected from a pre-set list of materials by selecting [Data].

MINIMUM MEASURABLE TEMPERATURE (PU151LT2.2 only)

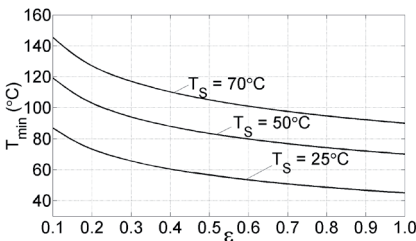

Graph showing the minimum measurable object temperature (T_{min}), determined by surface emissivity (ϵ) and sensor temperature (T_s).

- Setting Reflected Temperature Compensation

To enable and set reflected temperature compensation, use the main program menu to select:

[Setup] → [Reflection Compensation]

Reflected temperature compensation can be enabled/disabled using [Compensate for Reflected Temperature], and when enabled the temperature value can be set between 45 and 2000°C, depending on the model selected.

To store the changes in the sensor's memory, select [File] → [Save sensor processing parameters].

OPERATION

Once the sensor is in position and the appropriate power, air, water, and cable connections are secure, the system is ready for continuous operation by completing the following simple steps:

1. Turn on the power supply
2. Turn on the instrument or PC
3. Read / monitor the temperature

IMPORTANT

Be aware of the following when using the sensor:

- If the sensor is exposed to significant changes in ambient temperature (hot to cold, or cold to hot), allow 20 minutes for the temperature to stabilise before taking or recording measurements.
- Do not operate the sensor near large electromagnetic fields (e.g. around arc welders or induction heaters) or where energy from lamps, heaters and sunlight could be reflected into the lens.
Electromagnetic interference can cause measurement errors.
- Wire must be connected only to the appropriate terminals.

MAINTENANCE

Our customer service representatives are available for application assistance, calibration, repair, and solutions to specific problems. Contact our Service Department before returning any equipment. In many cases, problems can be solved over the telephone. If the sensor is not performing as it should, try to match the symptom below to the problem. If the table does not help, call Calnex for further advice.

TROUBLESHOOTING

Symptom	Probable Cause	Solution
No output	No power to sensor	Check power supply
Erroneous temperature	Incorrect wire connection	Check wire colour codes
Erroneous temperature	Faulty sensor cable	Verify cable continuity
Erroneous temperature	Field of view obstruction	Remove obstruction

LENS CLEANING

Keep the lens clean at all times. Any foreign matter on the lens would affect measurement accuracy. Blow off loose particles (if not using the air purge accessory) with an air 'puffer'.

GUARANTEE

Calnex guarantees each instrument it manufactures to be free from defect in material and workmanship under normal use and service for the period of two years from the date of purchase. This guarantee extends only to the original buyer according to Calnex terms and conditions of Sale.

Calex Electronics Limited

PO Box 2, Leighton Buzzard, Bedfordshire, England LU7 4AZ

Tel: +44 (0)1525 373178 Fax: +44 (0)1525 851319 Lo-call tel: 0845 3108053

Email: mail@calex.co.uk Online: <http://www.calex.co.uk>