

► Read and follow these safety instructions first and take notice of the operating instructions.

Safety instructions

1. The installation, initial operation and maintenance may be done by a qualified expert with electrical know-how only.
2. Comply with the local and statutory rules and regulations and/or the VDE 0100.
3. Take notice of the temperature specifications at the data plate.
4. A fuse (with max. 4A) has to be connected in series to the voltage supply.
5. Protect the signal contact from voltage peaks when inductive loads are connected.
6. The device may put into operation if it is closed, only.
7. Switch off the power supply, before opening the device. (touchdangerous voltage)

Operating instructions

1. Description

1.1 Intended use

The level indicator observes the filling level as a limit switch in silos and vessels. It can be used as full, demand and empty indicator for dusty and powdery, granulated and grainy bulk goods with a max. grain size up to 30 mm and with a bulk density of 0.3 t/m³ ... 1.0 t/m³.

1.2 Function

The bulk goods presses with its weight against the membrane. A tappet directly transfers the pressure from the membrane to the micro switch. When the bulk goods are decreasing, pressure is taken off the membrane and the switch will be interconnected.

1.3 Dimensions

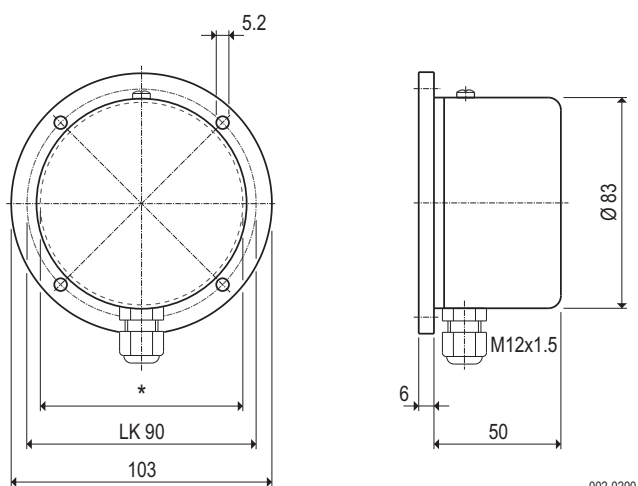

* Hole-Ø in the vessel max. 80mm

1.4 Technical data

| | |
|-------------------------|--|
| Manufacturer | MOLLET Füllstandtechnik GmbH |
| Address | Industriepark RIO 103 74706 Osterburken |
| Name | Membrane level indicator |
| Type | MFA |
| Temperature range | Ta -10 °C ... +60 °C |
| Signal contact | change-over contact, potentialfree |
| Capacity of the contact | Contact 2 A / 250 V AC |
| Switching voltage | 24 V ... 250 V AC or 12 V ... 65 V DC |
| Response delay | none |
| Sensitivity | 20 g ... 60 g adjustable |
| Cable connection | Flat connection 4.8x0.8 |
| Cable entry | Cable gland M12x1.5 |
| Type of protection | IP IP44 acc. to DIN EN 60529 |
| Overpressure safety | up to 0.5 bar |
| Weight | 200 g |
| Maintenance | none |
| Mounting position | any position |

1.5 Materials

| | |
|----------|--------------------|
| Housing | ABS |
| Membrane | Nitrile caoutchouk |

2. Installation

2.1 Preparation

- Check the membrane of visual transport damage.
- Read and follow the safety instructions and the operating instructions, before handling with the device !

2.2 Mounting in the vessel

Position the level indicator at the flange and fix it with 4 washers and screws M5.

2.3 Electrical connection

Circuit diagram

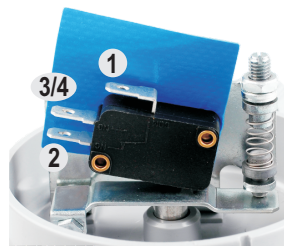
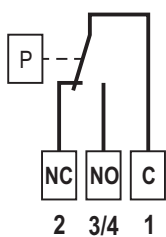

2.4 Cable gland

Screw on the cap nut until the cable gland is closed tightly.

3. Commissioning

Put the level indicator into operation only, if the installation and the electrical connection have been done correctly.

4. Setting of the sensitivity

- The level indicator is preset at sensitive.
- With the adjusting screw the device can be set less sensitive.
- Remove the safety screw from the housing cover.
- Pull off the cover from the lower part of housing.
- Set the sensitivity of the switch according to your needs with the adjusting screw. Clockwise insensitive.
- Put on the housing cover and fasten it with the screw.



5. Utilization

5.1 Normal operation

- Use the level indicator in its intended application only.
- The level indicator is provided for use in silos or vessels with pressureless operation.
- Comply with the specifications on the data plate. Check the membrane of the level indicator, when the permissible temperature of bulk goods was exceeded or was fallen short off.
- Damaged devices have to put out of operation immediately.

5.2 Inexpert handling

- Ignoring of the safety instructions and the operating instructions.
- Not intended use.
- Violation against applicable law and standards.

6. Maintenance

- Do maintenance work only, if the silo or the vessel is empty and if there is no overpressure or vacuum.
- Inspect in regular intervals if there is any wear or abrasion at the membrane. Define the control intervals, depending on the characteristics of the bulk goods.
- Replace the device in case of damage or abrasion of the membrane.

7. Storage

- Store the level indicator dry and dust-free.
- Protect the membrane against pointed objects and ultraviolet radiation.

8. Disposal

- The level indicator can be recycled.
- The disposal applies to the valid environmental guidelines according to the location of the carrier and the local manufacturing conditions.

EU-Konformitätserklärung EU-Declaration of Conformity

Wir/We

MOLLET Füllstandtechnik GmbH

Industriepark RIO 103
D-74706 Osterburken
Tel. 06291 64400 Fax 06291 9846

erklären hiermit, dass die Geräte:

declare that the devices:

Membran-Füllstand-Grenzschafter der Typenreihen:

Membrane level limit switches of type:

M ... , R ... , T ...

M ... , R ... , T ...

auf die sich diese Erklärung bezieht, den folgenden Normen oder normativen Dokumenten entsprechen:

to which this declaration relates is in accordance with the following standards or other normative documents:

Richtlinie 2014/35/EU (NSR-Richtlinie)
Richtlinie 2014/30/EU (EMV-Richtlinie)

Directive 2014/35/EU (Directive LVD)
Directive 2014/30/EU (Directive EMC)

und

and

**DIN EN 61010-1:2011, DIN EN 60529:2014
DIN EN 61326-1:2013**

**DIN EN 61010-1:2011, DIN EN 60529:2014
DIN EN 61326-1:2013**

Die grundlegenden Sicherheits- und Gesundheitsanforderungen werden erfüllt gemäß den Bestimmungen der Richtlinien und durch Einhaltung der Normen soweit es im Rahmen des Lieferumfangs möglich ist.

The Essential Health and Safety Requirements are assured by compliance with the directive and observance of the normative documents, as far as the scope of delivery allows.

Osterburken, 07. Januar 2020

Osterburken, January 7th 2020



Wolfgang Hageleit

Diese Erklärung darf nur unverändert weiterverbreitet werden.

This declaration is only allowed to hand out in unchanged form.