

QV 013-025 BA

Read and follow these safety instructions first and take notice of the operating instructions.

Safety instructions

1. The installation, maintenance, initial operation, removal and repair may be done only by qualified experts with knowledge about the handling of pressure equipment and pneumatic air compressors.
2. The statutory and other applicable regulations and standards have to be noticed and kept.
3. The maximum pressure and temperature given by the data plate have to be noticed and kept.
4. A pressure-reducing valve has to be installed in the control pressure supply line and it has to be set at the calculated control pressure.

Calculation	Example
shut off pressure (Process pressure PD)	2.0 bar
+ 2.5 bar (Control pressure over PD)	2.5 bar
= Control pressure to be set	4.5 bar

5. The control pressure given by the type plate must not be exceeded.
6. The differential pressure given by the type plate must not be exceeded.



ATTENTION! The articles 3, 4, 5 and 6 are to be strictly kept.
To high process or control pressure shortens the durability of the hose.

7. Initial operation and pressure admission only if the pinch valve is installed (e.g. mounted in a tubing)
8. If there is no conveying pipe mounted at one side, it has to be ensured by adequate measures (e.g. grid) that the access (e.g. put in fingers or hands) to the inside of the pinch valve is impossible.
Or place suitable warning informations e.g. crushing hazard.



ATTENTION! Crushing Hazard
It is strictly forbidden to put fingers, hands, other extremities or objects into the valve.
Sharp-edged objects damages the hose.

9. When the pinch valve is damaged the control medium has to be shut off immediately and the valve is to be released from any pressure e.g. by removal of the control medium conveying line and / or by turning the hand operation of the solenoid valve (directional valve) at "bleeding".
10. The pinch valve may be removed and demounted only in pressure-free condition.

Operating instructions

1. Specification

1.1 Intended Use

The pinch valve is for shutting off and dosing of powdery, grained, viscous, soiled and aggressive materials, gases, mixtures and liquids, e.g. to stop the flow of bulk goods during the pneumatic conveying.

1.2 Function

The elastic hose will be squeezed by the control medium. Present solids up to a determined size will be enclosed by the hose. After release of the control pressure the hose opens in its circular shape.

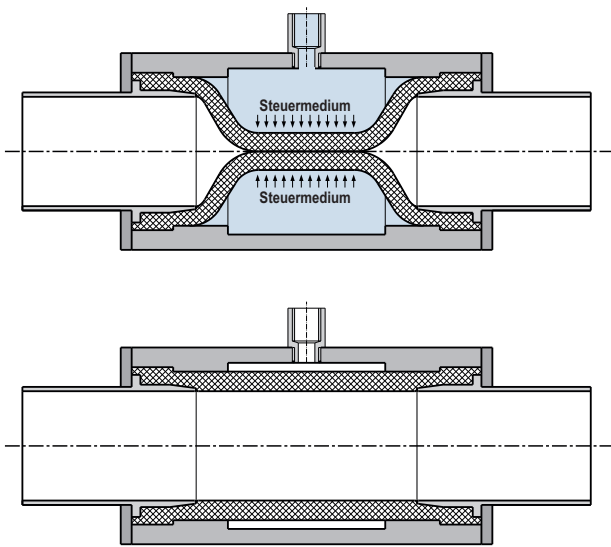

010-0230

1.3 Control

Control of the pinch valve should be done with a directional valve (3/2-way solenoid valve). For quick opening of the hose the installation of a quick air-exhaust valve at the control connection is recommended. To monitor of the control pressure a additional pressure switch can be installed.

1.4 Technical Data

Manufacturer	MOLLET Füllstandtechnik GmbH		
Address	Industriepark RIO 103 74706 Osterburken		
Name	Pinch Valve		
Type	QV		
Control medium	Compressed air, inert gas, water (Oil at request)		
Process pressure	QV 013	maximum	6.0 bar
	QV 020	maximum	6.0 bar
	QV 025	maximum	4.0 bar
	Higher process pressure at request		
Control pressure	2.5 bar over process pressure		
Differential pressure	maximum 2.5 bar		
Temperature range	Hose	NR	maximum +80 °C wet
Temperature range	Hose	NW	maximum +70 °C wet
Temperature range	Hose	NRE	maximum +80 °C wet
Temperature range	Hose	VI	maximum +100 °C wet
Temperature range	Hose	EP	maximum +120 °C wet
Mounting position	any		
Maintenance	none		

2. Installation

2.1 Preparation

Read and follow the safety instructions and the operating instructions, before handling with the device !

2.2 Mechanical Connection

The pinch valve is factory-provided pre-assembled and has only to be connected with the joints of the plant. Avoid charge of the pinch valve and its connection with bending forces and vibrations.

To avoid damaging of the rubber hose do not carry out welding works immediately nearby the valve.

2.2 Control Pressure Connection

- Connect the pinch valve with the control pressure supply line.
- Adjust the pressure-reducing valve with the according to article 4 of the safety instructions calculated control pressure.

3. Utilization

3.1 General Information

The pinch valve with its equipment may be operated and monitored by expert and instructed personnel only that employees and other persons will not be brought in danger. The operating instruction with the safety instructions has to be available to the operating and maintenance personnel. Take care of the country of installation's national regulations about the operation of pressure equipment.

3.2 Putting into operation

Commissioning of the pinch valve only if

- it is fix connected with the assigned joints,
- the pressure-reducing valve is installed at the control pressure supply line and it is pre-set,
- maybe necessary safety devices are onhand and operative.

If the pinch valve is installed in a suction line with a vacuum >0.05 bar, the air exhausting connection of the directional valve has to be connected with the vacuum piping to achieve a pressure equalization at the hose.

3.3 Normal operation

- Use the pinch valve in its intended application only.
- Keep the safety instructions.
- The protection and safety devices and warning informations attached to the pinch valve must not be removed.
- The pinch valve is open without control pressure and is closing only if the control pressure is actuated.
- If the pinch valve is damaged during operation, put it immediately out of operation and release it from any pressure.
- If the permissible pressure or the permissible process temperature was exceeded, check the hose.

3.4 Improper Use

- Ignoring the safety instructions and the operating instructions.
- Use of the pinch valve in non-intended application.
- Operating of the pinch valve by personnel who is not authorized or not proper instructed.
- Mounting of spare parts which are no original parts.
- Violation against applicable law and standards.

4. Maintenance and Servicing

4.1 General Information

Carry out maintenance and repair work only if the pinch valve is released from any pressure and disconnected from the control pressure supply line. If an electrical supply for accessories (e.g. electrical directional valve) is present it has to be also disconnected. If it's to reckon with the exhaust of hazardous substances during the maintenance special protection measures (e.g. personal protection equipment) is necessary.

4.2 Inspection

Inspect in regular intervals

- safety devices for proper function,
- the correct pre-set of the pressure-reducing valve in the control pressure supply line,
- the hose for tear and wear,
- all connections and joints for tight fit.

Schedule the inspection intervals according to

- the kind of material which has to be shut off,
- the frequency of use.

4.3 Servicing

- Damaged protection and safety devices, hoses, connections and joints has to be repaired or replaced by new ones immediately.
- The pinch valve must not be used until the complete restoration of the proper function.

5. Storage

Store the pinch valve and the spare hoses dry, dust-free and protected against ultraviolet radiation.

- Storage temperature -20 °C ... +40 °C
- Storage duration maximum 24 months

6. Disposal

- The valve can be recycled.
- The disposal applies to the valid environmental guidelines according to the location of the carrier and the local manufacturing conditions.

Typenbezeichnung / Bestell-Nr.
Type specification / Order code

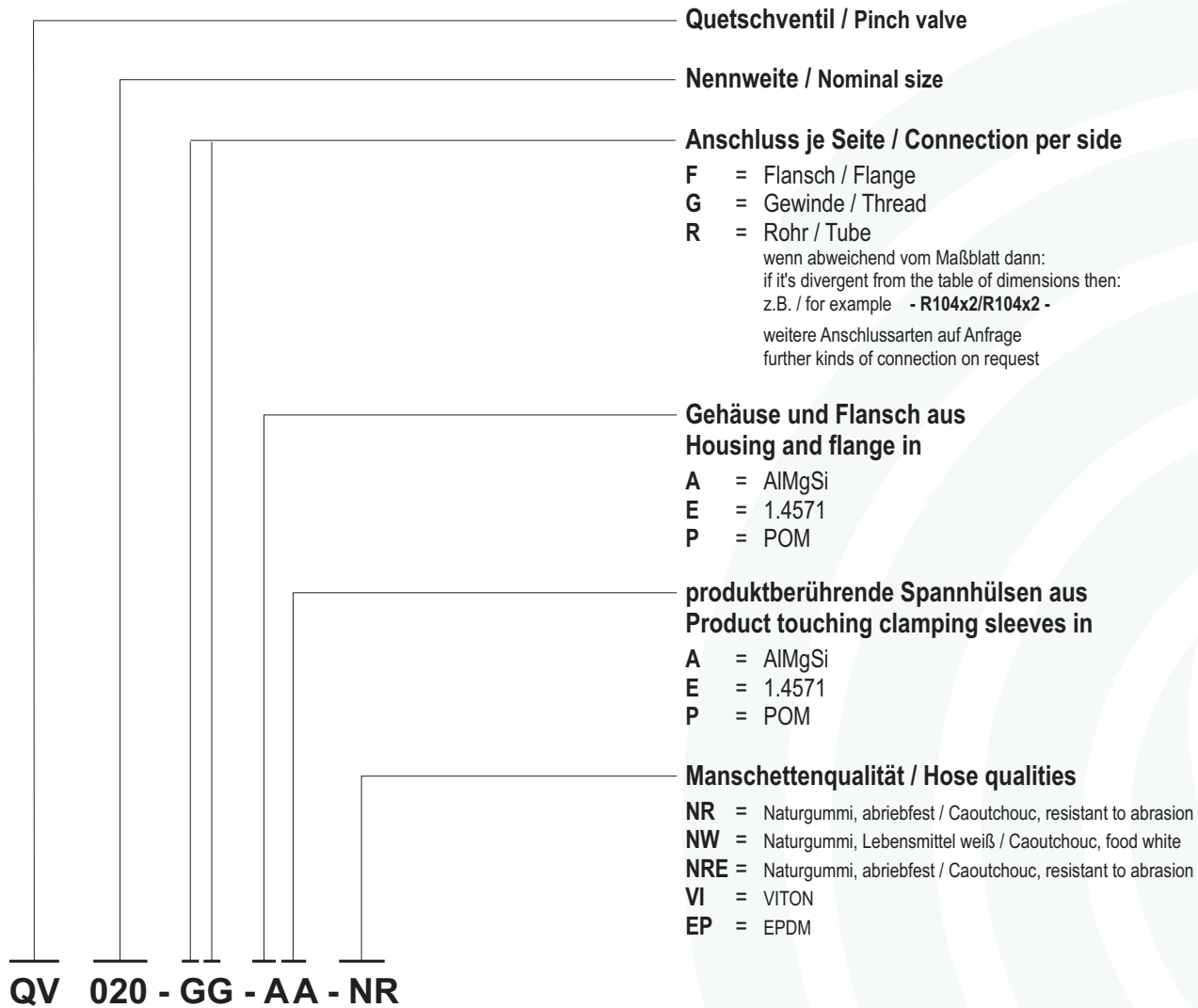

Abmessungen / Dimensions

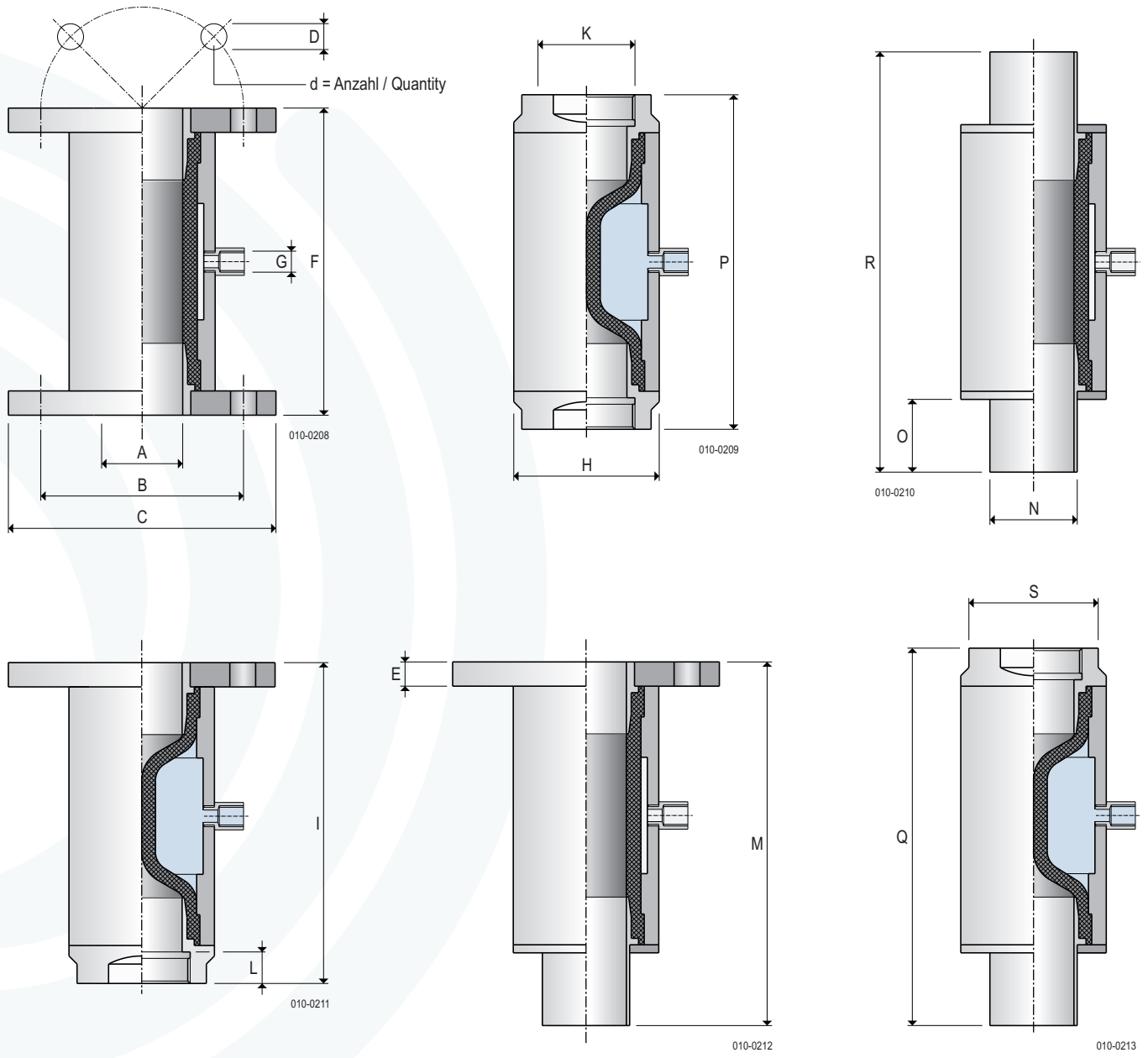

Typ/type	A	B	C	D	d	E	F	G	H	I	K	L	M	N	O	P	Q	R	S	NI
QV013	13							1/8	40		1/2	14				120			35	0,02
QV020	20							1/8	50		3/4	15				130			40	0,03
QV025	25							1/8	55		1	15				130			46	0,04
QV032	32							1/8	70		1/4	15				165			60	0,06
QV040	40	110	150	M16	4	12	178	1/8	80	188	1 1/2	18	216	40x1,5	45	197	226	254	70	0,12
QV050	50	125	165	M16	4	15	190	1/8	90	199	2	20	225	50x1,5	45	207	234	260	80	0,20
QV065	65	145	185	M16	4	15	225	1/4	110	233	2 1/2	20	280	65x2	65	240	288	335	100	0,40
QV080	80	160	200	M16	4	15	270	1/4	140	280	3	23	335	80x2	74	290	345	400	125	0,80
QV100	100	180	220	M16	8	15	310	1/4	160	320	4	23	396	100x2	93	330	406	482		1,45
QV125	125	210	250	M16	8	20	390	3/8	200	395	5	26	470	125x2	90	400	500	550		3,60

Steuerraum-
Volumen *
Volume of
control room

* Verbrauch in Normal-Liter je Schaltfunktion
* Consumption per switching function in normal liter

Einzelteile
Spare parts

MOLLET sinus pinch valve

QV-013

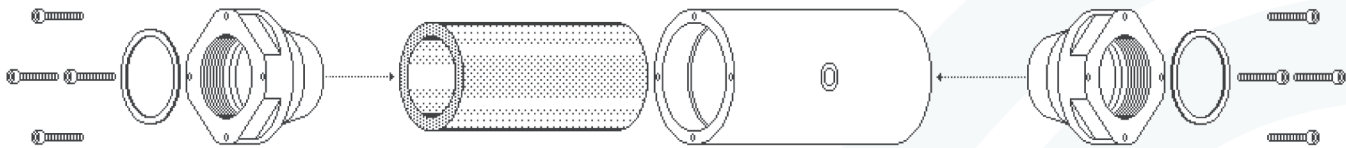

Pos. Item	Benennung Reference	Bestellcode Order code	DIN	Werkstoff Material
1	Zylinderschraube mit Innensechskant Pan head screw with hexagon socket	0912-04X020-STV	912	Stahl, verzinkt Steel, galvanized
2	Dichtring / Gasket	016-001-DIR-NBR		NBR, schwarz / NBR, black
3	Gewinde-Spannhülse Thread clamping sleeve	QV-GS013-AL		Al Mg 3
	Gewinde-Spannhülse Thread clamping sleeve	QV-GS025-ES		Edelstahl 1.4571 / Stainless steel 316 Ti
	Gewinde-Spannhülse Thread clamping sleeve	QV-GS025-P		POM
4	MOLLET-sinus-Manschette MOLLET-sinus-hose	QV-SM013-NR		Naturgummi abriebfest Caoutchouc resistant to abrasion
	MOLLET-sinus-Manschette MOLLET-sinus-hose	QV-SM013-NRE		Naturgummi abriebfest, ATEX Caoutchouc resistant to abrasion, ATEX
	MOLLET-sinus-Manschette MOLLET-sinus-hose	QV-SM013-NW		Naturgummi Lebensmittel weiß Caoutchouc food white
	MOLLET-sinus-Manschette MOLLET-sinus-hose	QV-SM013-EP		EPDM
	MOLLET-sinus-Manschette MOLLET-sinus-hose	QV-SM013-VI		VITON
5	Gehäuse / Housing	QV-GH013-AL		Al Mg Si 0,5
	Gehäuse / Housing	QV-GH013-ES		Edelstahl 1.4571 / Stainless Steel 316 Ti
	Gehäuse / Housing	QV-GH013-P		POM

Einzelteile
Spare parts

MOLLET sinus pinch valve

QV-020

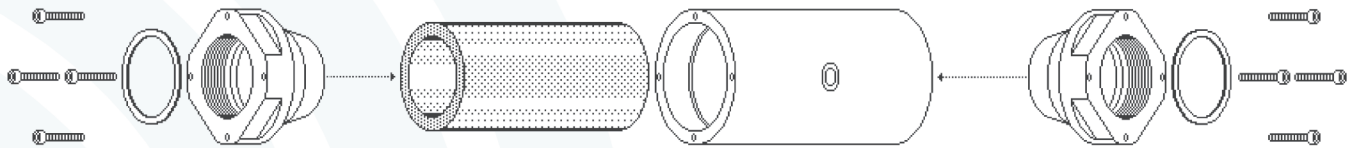

Pos. Item	Benennung Reference	Bestellcode Order code	DIN	Werkstoff Material
1	Zylinderschraube mit Innensechskant Pan head screw with hexagon socket	0912-04X020-STV	912	Stahl, verzinkt Steel, galvanized
2	Dichtring / Gasket	020-002-DIR-NBR		NBR, schwarz / NBR, black
3	Gewinde-Spannhülse Thread clamping sleeve	QV-GS020-AL		Al Mg 3
	Gewinde-Spannhülse Thread clamping sleeve	QV-GS025-ES		Edelstahl 1.4571 / Stainless steel 316 Ti
	Gewinde-Spannhülse Thread clamping sleeve	QV-GS025-P		POM
4	MOLLET-sinus-Manschette MOLLET-sinus-hose	QV-SM020-NR		Naturgummi abriebfest Caoutchouc resistant to abrasion
	MOLLET-sinus-Manschette MOLLET-sinus-hose	QV-SM020-NRE		Naturgummi abriebfest, ATEX Caoutchouc resistant to abrasion, ATEX
	MOLLET-sinus-Manschette MOLLET-sinus-hose	QV-SM020-NW		Naturgummi Lebensmittel weiß Caoutchouc food white
	MOLLET-sinus-Manschette MOLLET-sinus-hose	QV-SM020-EP		EPDM
	MOLLET-sinus-Manschette MOLLET-sinus-hose	QV-SM020-VI		VITON
5	Gehäuse / Housing	QV-GH020-AL		Al Mg Si 0,5
	Gehäuse / Housing	QV-GH020-ES		Edelstahl 1.4571 / Stainless Steel 316 Ti
	Gehäuse / Housing	QV-GH020-P		POM

Einzelteile
Spare parts

MOLLET sinus pinch valve

QV-025

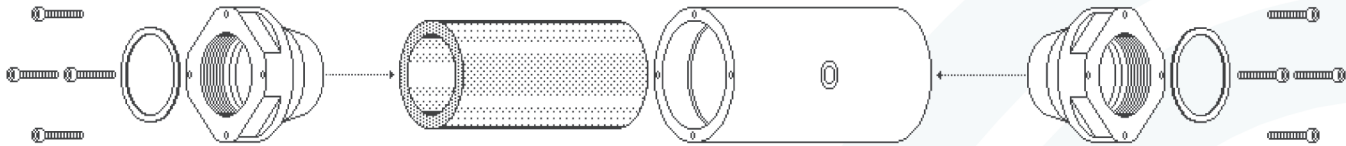

Pos. Item	Benennung Reference	Bestellcode Order code	DIN	Werkstoff Material
1	Zylinderschraube mit Innensechskant Pan head screw with hexagon socket	0912-04X025-STV	912	Stahl, verzinkt Steel, galvanized
2	Dichtring / Gasket	025-002-DIR-NBR		NBR, weiß / NBR, white
3	Gewinde-Spannhülse Thread clamping sleeve	QV-GS025-AL		Al Mg 3
	Gewinde-Spannhülse Thread clamping sleeve	QV-GS025-ES		Edelstahl 1.4571 / Stainless steel 316 Ti
	Gewinde-Spannhülse Thread clamping sleeve	QV-GS025-P		POM
4	MOLLET-sinus-Manschette MOLLET-sinus-hose	QV-SM025-NR		Naturgummi abriebfest Caoutchouc resistant to abrasion
	MOLLET-sinus-Manschette MOLLET-sinus-hose	QV-SM025-NRE		Naturgummi abriebfest, ATEX Caoutchouc resistant to abrasion, ATEX
	MOLLET-sinus-Manschette MOLLET-sinus-hose	QV-SM025-NW		Naturgummi Lebensmittel weiß Caoutchouc food white
	MOLLET-sinus-Manschette MOLLET-sinus-hose	QV-SM025-EP		EPDM
	MOLLET-sinus-Manschette MOLLET-sinus-hose	QV-SM025-VI		VITON
5	Gehäuse / Housing	QV-GH025-AL		Al Mg Si 0,5
	Gehäuse / Housing	QV-GH025-ES		Edelstahl 1.4571 / Stainless steel 316 Ti
	Gehäuse / Housing	QV-GH025-P		POM



Hersteller-Bescheinigung Manufacturer`s Certificate

Wir/We

MOLLET Füllstandtechnik GmbH

Industriepark RIO 103
D-74706 Osterburken
Tel. 06291 64400 Fax 06291 9846

bescheinigen hiermit, dass die Geräte:

**pneumatisches Sinus-Quetschventil
MOLOSvalve** der Typenreihen:

QV013-... bis QV025-...

auf die sich diese Bescheinigung bezieht, den folgenden
Normen oder normativen Dokumenten entsprechen:

Richtlinie 2014/68/EU (Druckgeräte-Richtlinie)

Die grundlegenden Sicherheits- und Gesundheitsanforderungen werden erfüllt gemäß den Bestimmungen der Richtlinie.

Einstufung:

Druckhaltendes Ausrüstungsteil

Mediumeigenschaft nach Artikel 13:

Gruppe 1 - gefährlich, mit Ausnahme instabiler und brennbare Gase

brennbare Gase sowie pneumatischer Transport von brennbaren Stäuben nur mit einem ☸ -Kennzeichen auf dem Typenschild

Mediumzustand:

gasförmig oder flüssig, wenn pD >0,5 bar

Angewendetes Konformitätsverfahren:

keines, es gilt die gute Ingenieurpraxis

Diese Hersteller-Bescheinigung ist nur gültig in Verbindung mit der aktuellen Betriebsanleitung

Osterburken, 07. Januar 2019



Diese Bescheinigung darf nur unverändert weiterverbreitet werden.

declare that the devices:

**pneumatic sinus-pinch-valve
MOLOSvalve** of type series:

QV013-... to QV025-...

to which this certificat relates is in accordance with the following standards or other normative documents:

Directive 2014/68/EU (Pressure Equipment Directive)

The Essential Health and Safety Requirements are assured by compliance with the directive and observance of the normative documents.

Categorization:

Pressure-maintaining components

Fluid group acc. to art. 13:

Group 1 - dangerous, except for unstable and flammable gases

flammable gases and pneumatic conveying of flammable dusts only with a ☸ -sign at the type plate

Condition of fluid:

gaseous or liquid, if pD >0.5 bar

Applied conformity assesement procedures:

none, accordance with the sound engineering practice

The manufacturer`s certificate is only valid in connection with our current operating instructions.

Osterburken, January 7th 2019

Wolfgang Hageleit
Geschäftsführer
Managing Director

This certificat is only allowed to hand out in unchanged form.

Einbauerklärung

im Sinne der EG-Richtlinie Maschinen 2006/42/EG, Anhang II, Nr. 1 B

Declaration of Incorporation

according to EC Machinery Directive 2006/42/EC, Annex II, part 1 B

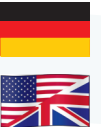

Wir/We

MOLLET Füllstandtechnik GmbH

Industriepark RIO 103
D-74706 Osterburken
Tel. 06291 64400 Fax 06291 9846

erklären hiermit, dass das druckhaltende Ausrüstungsteil:

pneumatisches Sinus-Quetschventil
MOLOSvalve

der Typenreihe: **QV ... - - - - -**

mit den elektrischen Betriebsmitteln:
Magnetventil und Druckschalter der Typenreihe:

0 820 005 ... und Q-DS901-3

in der gelieferten Ausführung zum Einbau in eine Ausrüstung, Anlage oder Maschine bestimmt sind und alle grundlegenden Anforderungen der Maschinenrichtlinie 2006/42/EG erfüllen, soweit es im Rahmen des Lieferumfangs möglich ist. Ferner erklären wir, dass die speziellen technischen Unterlagen nach Anhang VII, Nr. B erstellt wurden.

Die elektrischen Betriebsmittel entsprechen den Bestimmungen der Richtlinie 2014/30/EU über elektromagnetische Verträglichkeit, soweit es im Rahmen des Lieferumfangs möglich ist.

Die Schutzziele der Richtlinie 2014/35/EU über elektrische Betriebsmittel werden eingehalten.

Wir verpflichten uns, den Marktaufsichtsbehörden auf begründetes Verlangen die speziellen Unterlagen zu den Quetschventilen über unsere Dokumentationsabteilung zu übermitteln.

Die Quetschventile dürfen erst dann in Betrieb genommen werden, wenn ggf. festgestellt wurde, dass die Ausrüstung, Anlage oder Maschine, in die diese Quetschventile eingebaut werden sollen, den Bestimmungen der Maschinenrichtlinie 2006/42/EG entspricht und die EU-Konformitätserklärung gemäß Anhang II, Nr. 1 A ausgestellt ist.

Osterburken, 07.07.2019



Diese Erklärung darf nur unverändert weiterverbreitet werden.

declare herewith, that the:

pneumatic sinus-pinch-valve
MOLOSvalve

of type series: **QV ... - - - - -**

with the electrical accessories:
Solenoid valve and pressure switch of the series:

0 820 005 ... and Q-DS901-3

in the delivered version, are intended to be incorporated into other equipment, plant or machinery and are complying with all essential requirements of the Machinery Directive 2006/42/EC, as far as the scope of delivery allows. Additional we declare that the relevant technical documentation is compiled in accordance with part B of Annex VII.

The pinch valves are in conformity with the EC Directive 2014/30/EU relating to electromagnetic compatibility, as far as the scope of delivery allows.

The safety objectives of the EC Directive 2014/35/EU relating to electrical equipment are observed.

We commit to transmit, in response to a reasoned request by the market surveillance authorities, relevant documents on the pinch valves by our documentation department.

The pinch valves must not be put into service, until the final equipment, plant or machinery into which the pinch valve is to be incorporated has been declared in conformity with the provisions of the Machinery Directive 2006/42/EC, where appropriate, and until the EU Declaration of Conformity according to part 1 A of Annex II is issued.

Osterburken, July 7th, 2019

Wolfgang Hageleit
Geschäftsführer
Managing Director

This declaration is only allowed to hand out in unchanged form.